

Proposal for a Computational Model of Story Understanding

Mark Alan Finlayson & Patrick Henry Winston

{markaf, phw}@mit.edu

Computer Science and Artificial Intelligence Laboratory, MIT, 32 Vassar St., Cambridge, MA 02139 USA

Motivation

Our interest is in understanding how culture leads us to different conclusions for the same ‘data’ - for example, learning of the America’s invasion of Iraq, or the overthrow of the Shah in Iran. We would like a concrete framework within which we can study how different points of view are formed of events like these by reason of different bases of cultural experience. Loosely, we are interested in processes that make up the convolution operator in the diagram below.

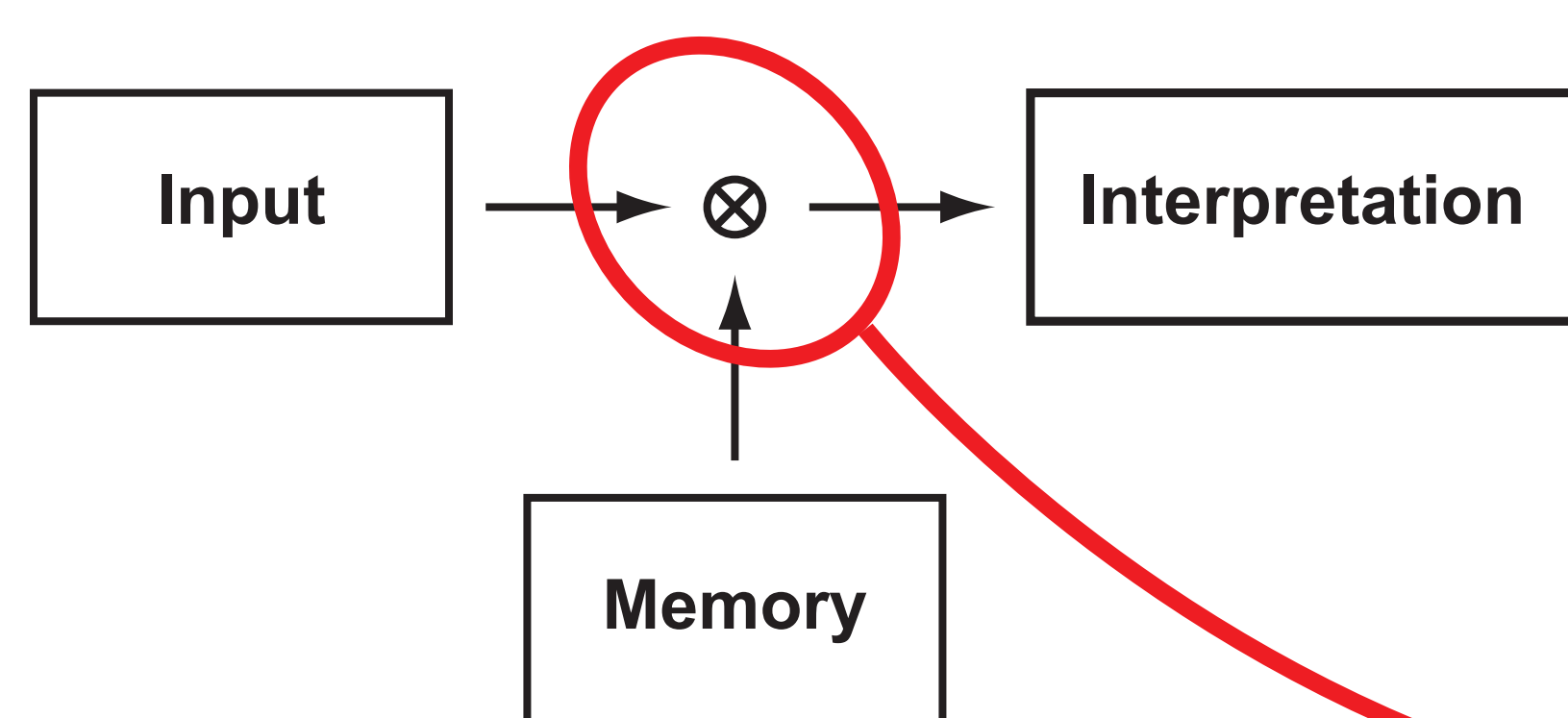

Basic Model & Assumptions

Our starting assumption is that people have a small suite of pre-figured interpretations, or stories, gained through cultural experience. These stories are matched to incoming descriptions through a modified analogical mapping process that closes the feedback loop through introduction of redescription.

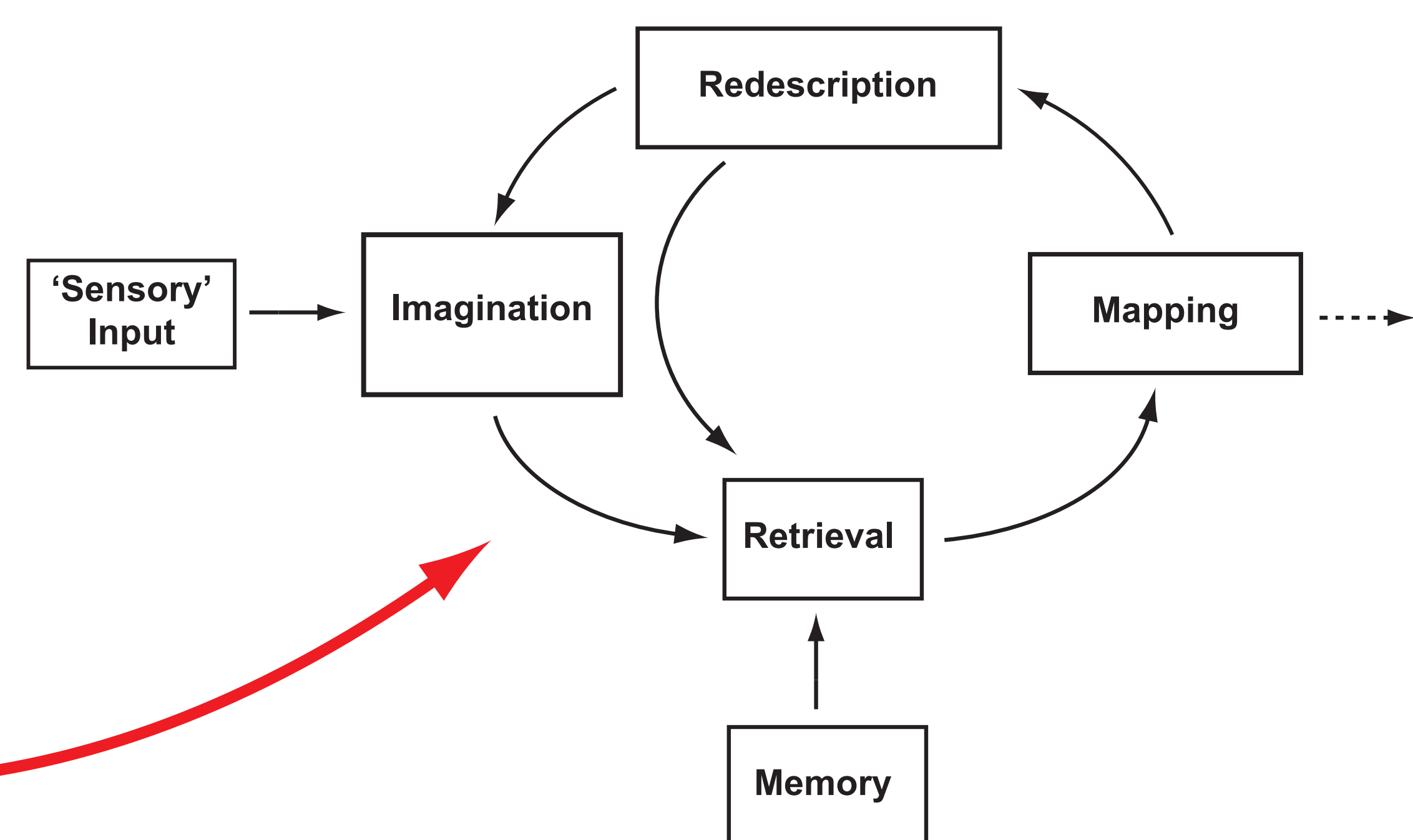

Retrieval

This process has been fairly well studied, and there are several strategies already available that we can integrate with little change. Among them, MAC/FAC (left) and Intermediate-Features-based Retrieval (right).

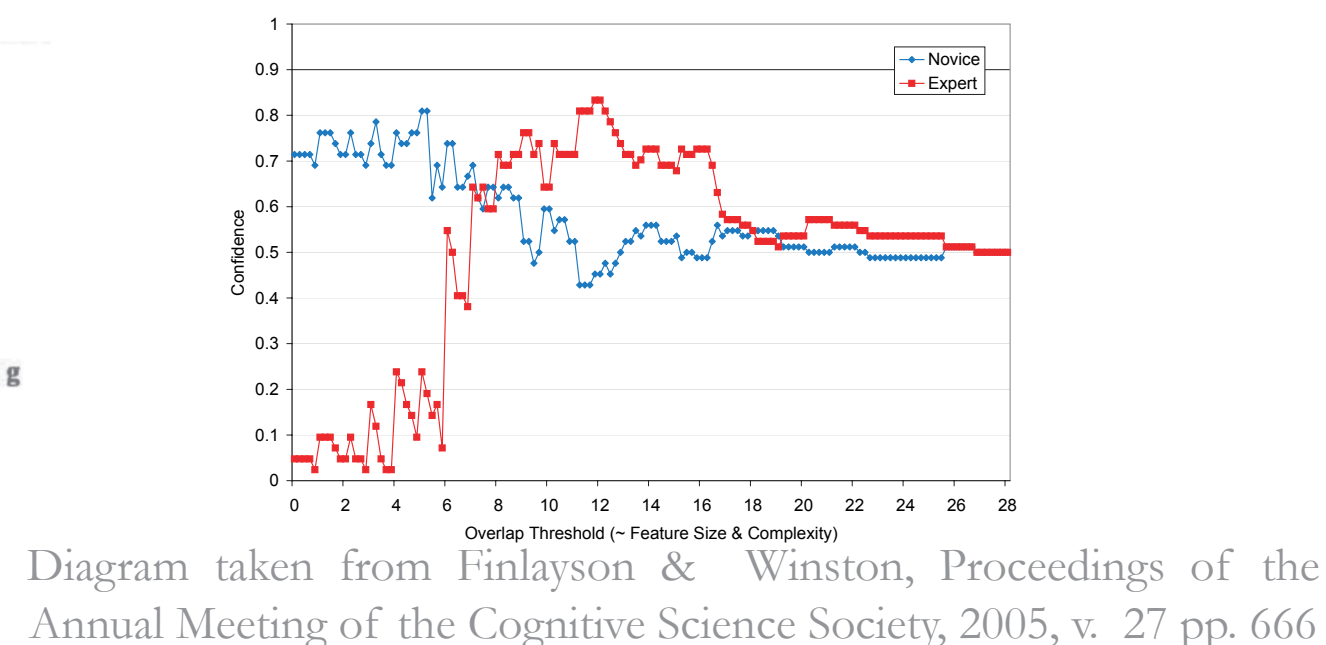
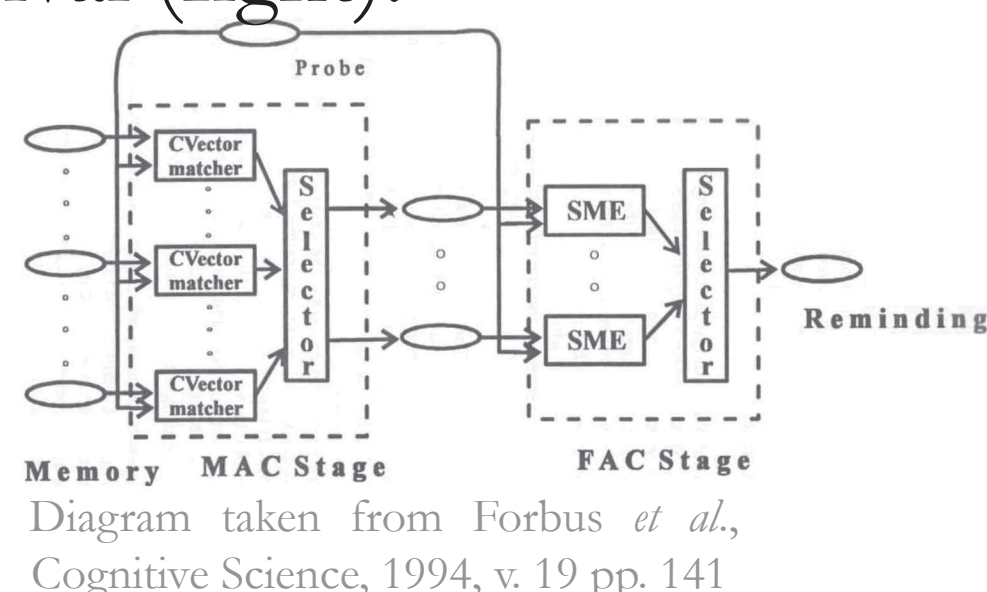

Mapping

Mapping has also been well studied, although there is little insight into constructing analogies involving multiple representations. Here, the best strategy would likely assimilate the guiding principles from the Structure Mapping Engine and the Incremental Analogy Machine.

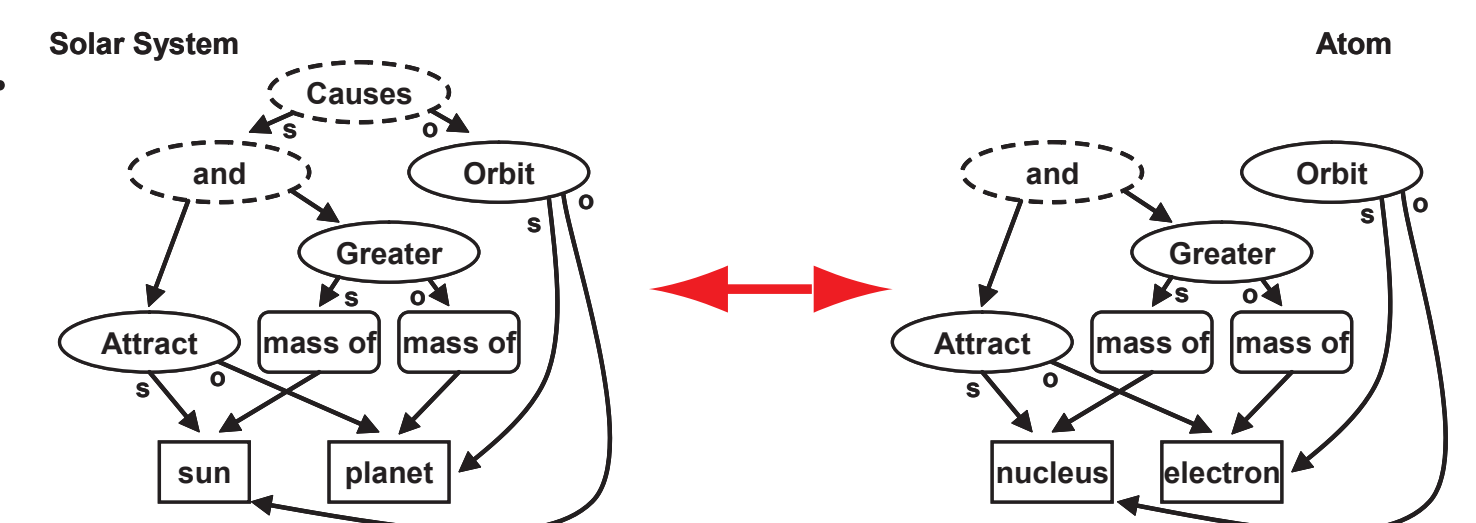

Redescription

This process needs significant attention. Progress was shown in (Yan & Forbus 2003), but more needs to be done.

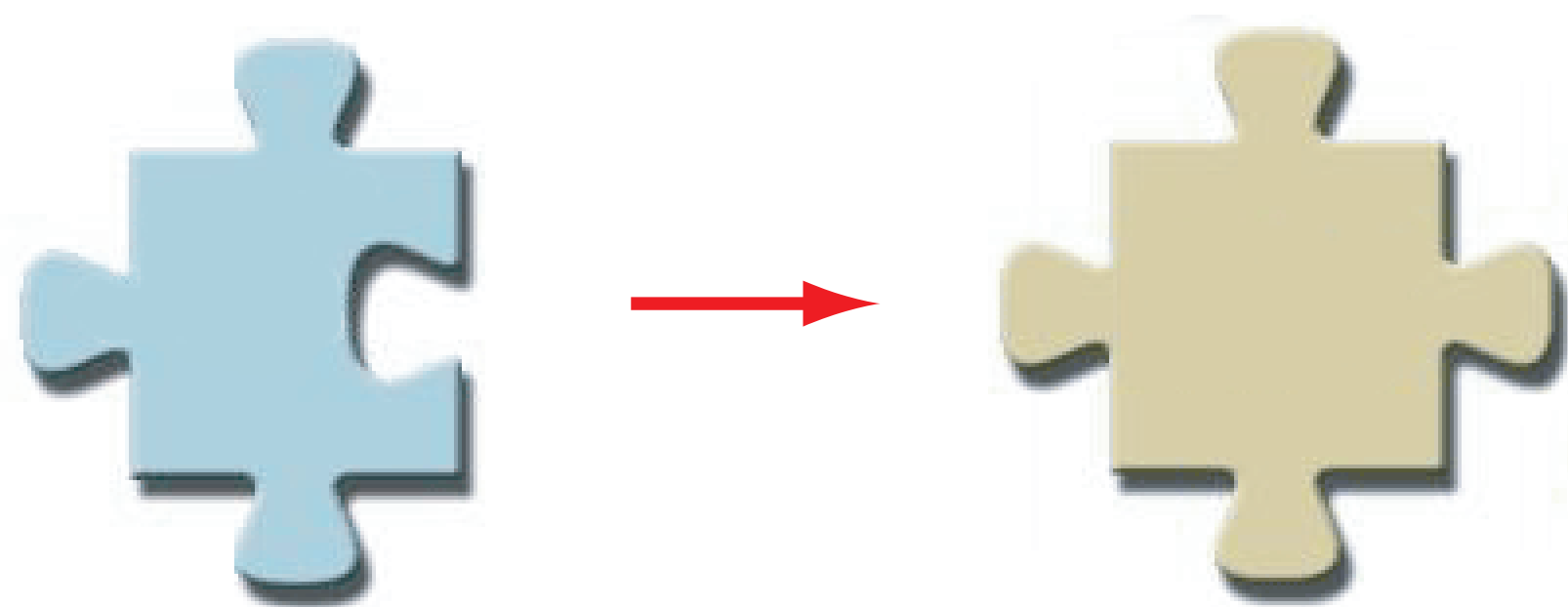

Imagination

When redescription or elaboration cannot be carried out in a purely symbolic fashion, we must appeal to other processes. Here, the ability to imagine how a situation might be different, what might be missing, what can be ignored, is critical. We conceive of imagination as a type of qualitative simulation of the circumstances, drawing on world knowledge to produce the simulations and intermediate-level perceptual processes (visual, auditory, spatial, etc.) to reparse them into symbolic representations that can then be fed back into the interpretive loop.

Acknowledgements

This work is supported in part by the National Science Foundation under grant number IIS-0413206, and by the Air Force Office of Scientific Research under MURI grant number FA9550-05-1-0321.

