

Story Understanding via Learning and Exploiting Plot Patterns

Mark A. Finlayson & Patrick H. Winston
 Computer Science and Artificial Intelligence Laboratory
 Massachusetts Institute of Technology
 Cambridge, MA, 02139, USA
 {markaf, phw}@mit.edu

1. The Story Workbench

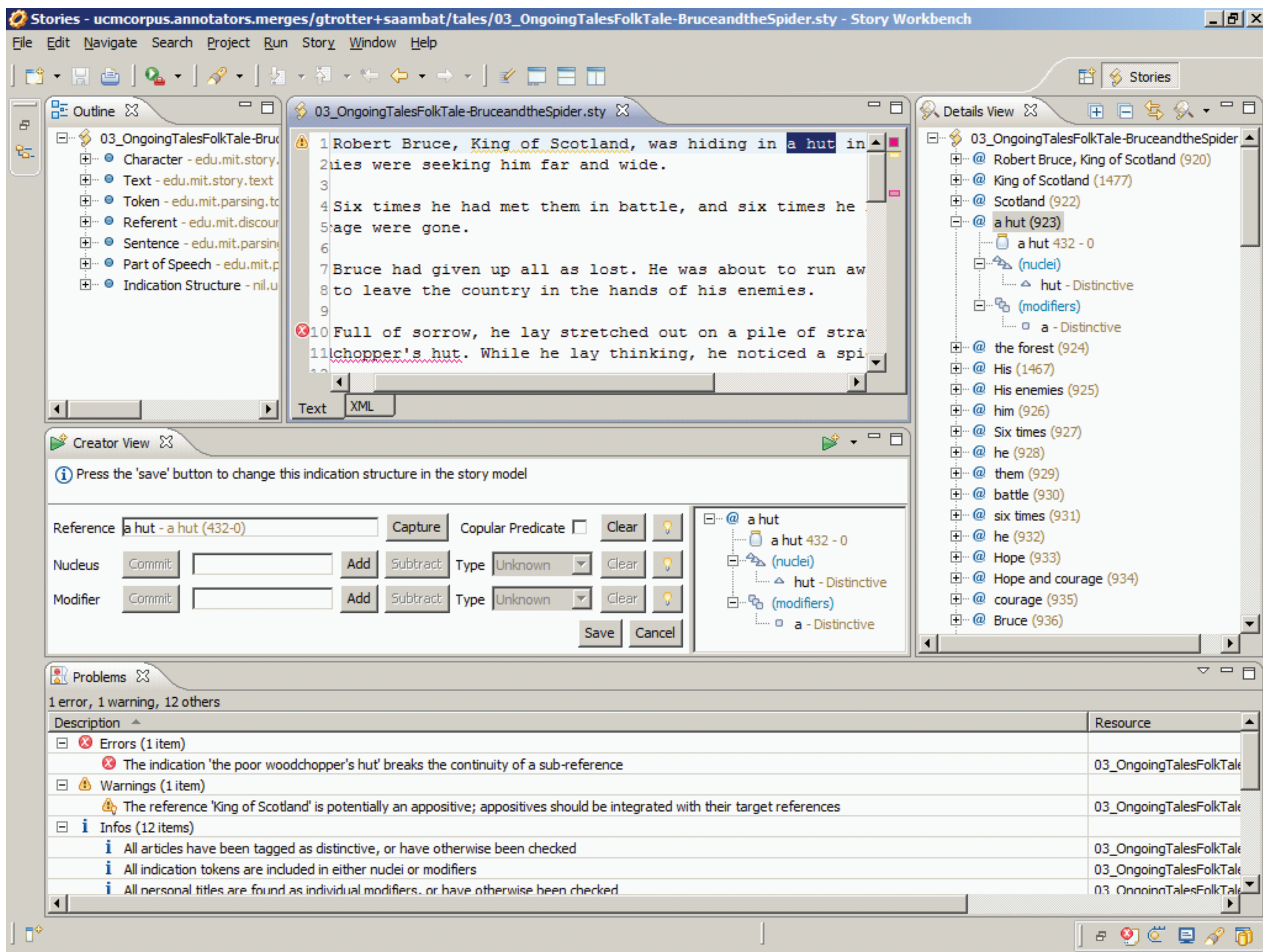

3. Analogical Story Merging

(1) The boy and girl were playing. He chased her, but she ran away. She thought he was gross.
 (2) The man stalked the woman and scared her. She fled town. She decided he was crazy.

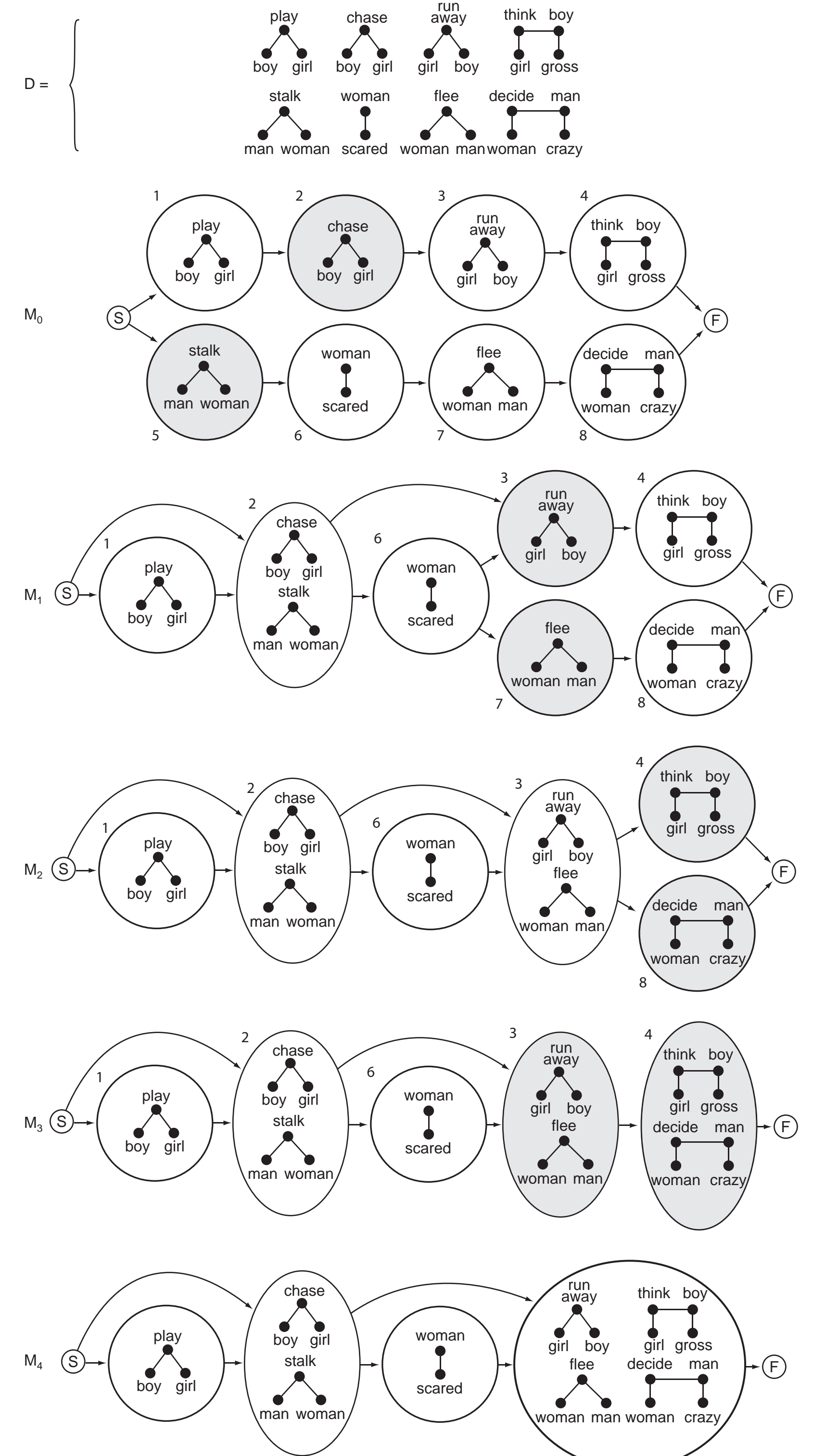

In early 2010, Google's servers were attacked by Chinese hackers. As such, Google decided to withdraw from China, removing its censored search site and publicly criticizing the Chinese policy of censorship. In response, a week later China banned all of Google's search

Pipeline System

Input Stories

In 1998, the U.S. embassy in Cairo was bombed by Afghan terrorists, killing over 200 people and 12 Americans. Two weeks later, The U.S. retaliated for the bombing with cruise missile attacks on the terrorist's camps in Afghanistan, which were largely unsuccessful. The terrorists claimed that the bombing was a response to America torturing Egyptian terrorists several months earlier.

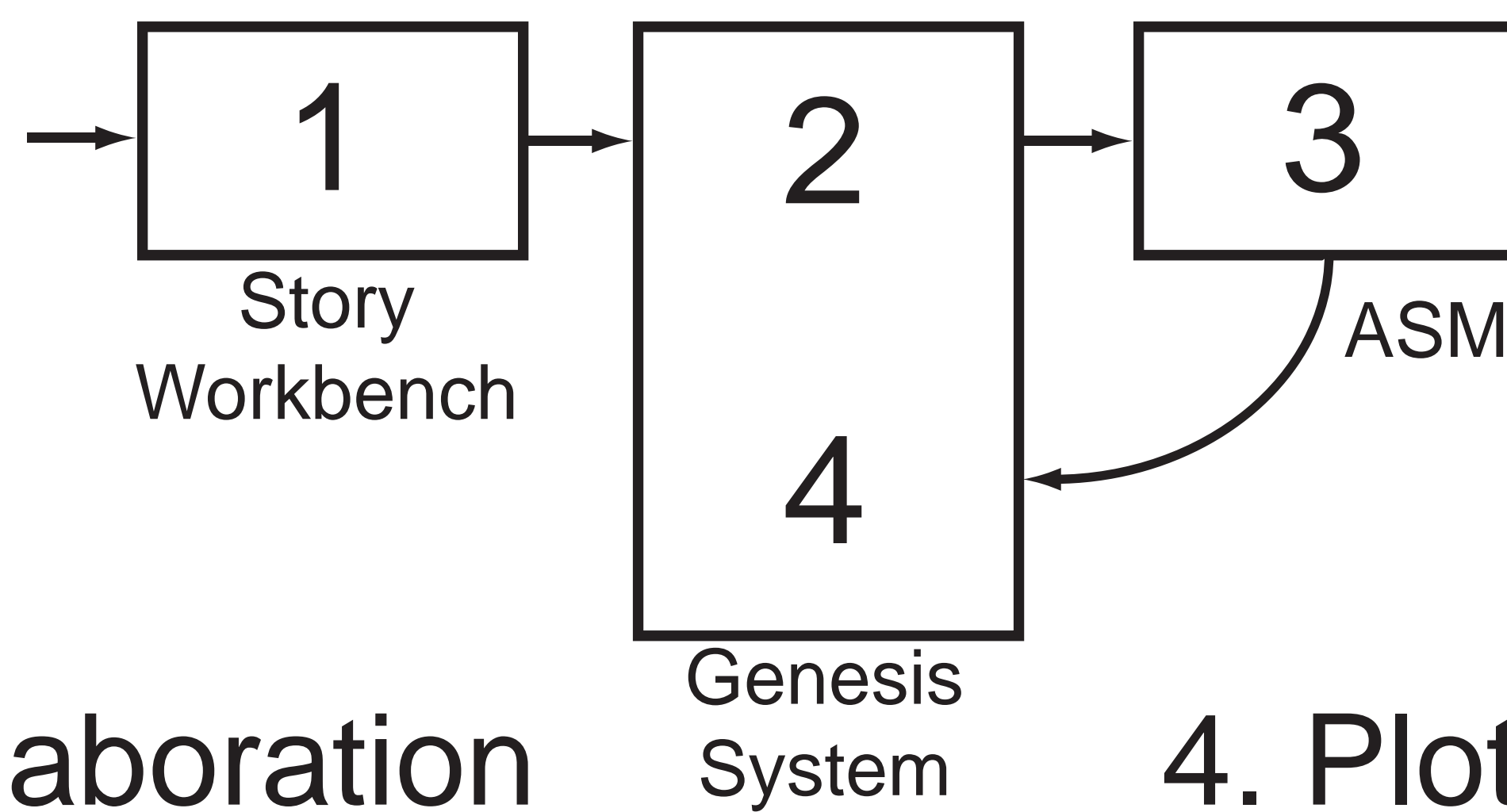

2. Commonsense Elaboration

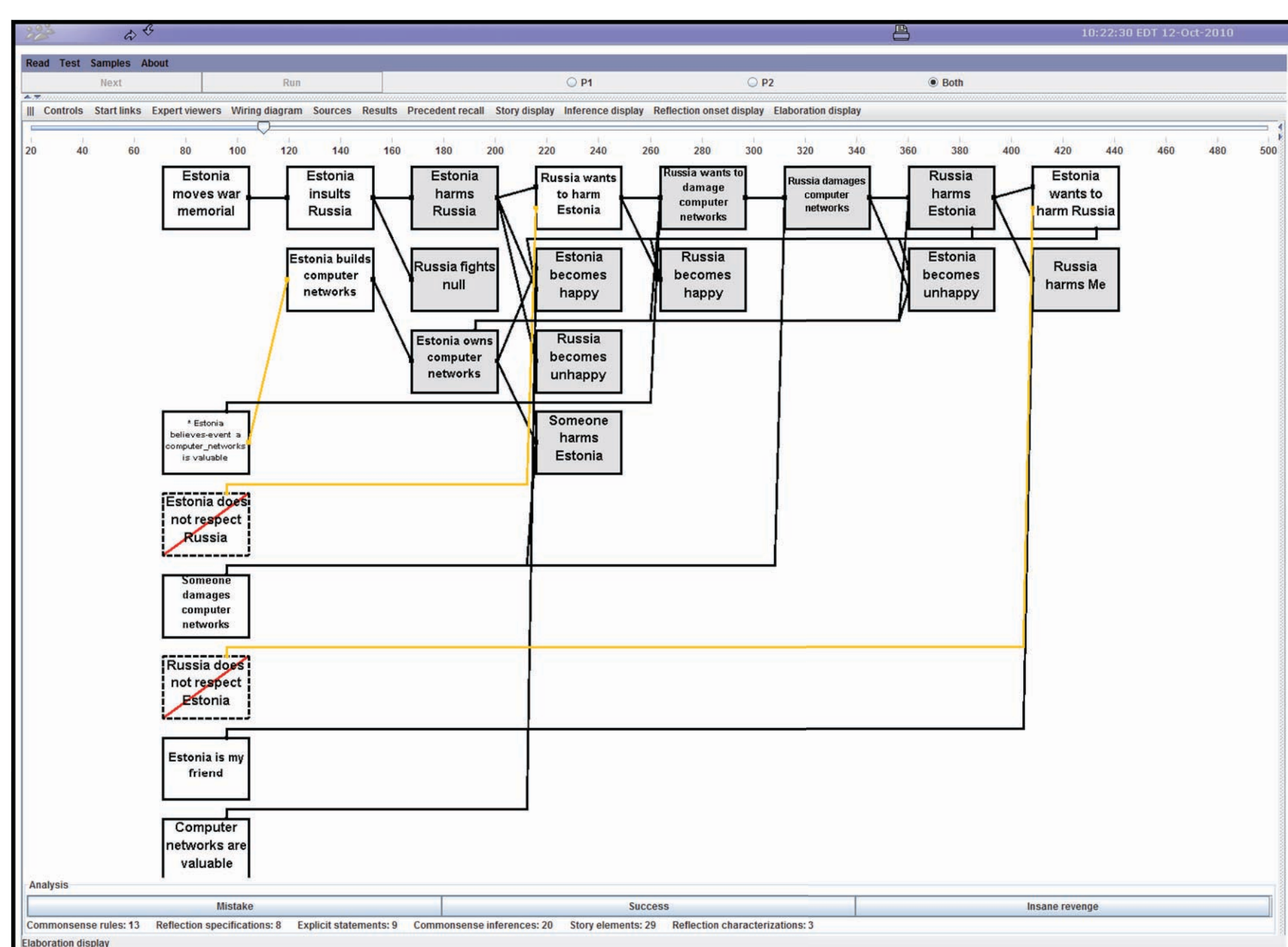

4. Plot Pattern Discovery

