

A Characterization of Integral Input to State Stability

David Angeli, Eduardo D. Sontag, Yuan Wang

Abstract—

The notion of input to state stability (ISS) is now recognized as a central concept in nonlinear systems analysis. It provides a nonlinear generalization of finite gains with respect to supremum norms and also of finite L^2 gains. It plays a central role in recursive design, coprime factorizations, controllers for non-minimum phase systems, and many other areas. In this paper, a newer notion, that of integral input to state stability (iISS), is studied. The notion of iISS generalizes the concept of finite gain when using an integral norm on inputs but supremum norms of states, in that sense generalizing the linear “ H^2 ” theory. It allows to quantify sensitivity even in the presence of certain forms of nonlinear resonance. We obtain here several necessary and sufficient characterizations of the iISS property, expressed in terms of dissipation inequalities and other alternative and nontrivial characterizations. These characterizations serve to show that integral input to state stability is a most natural concept, one which might eventually play a role at least comparable to, if not even more important than, ISS.

Keywords— input to state stability, nonlinear systems, finite gain, dissipation inequalities, tracking

I. INTRODUCTION

One of the main issues in control design concerns the study of closed-loop sensitivity to disturbances, and, more generally, of the dependence of state trajectories on actuator and measurement errors, magnitudes of tracking signals, and the like. In linear systems theory, classical frequency-domain measures of performance such as root loci and gain-phase characteristics have led to the modern theories of “ H^∞ ” control and its variants.

During the last 10 years or so, the notion of *input to state stability* (ISS) was formulated (in [23]), and quickly became a foundational concept upon which much of modern *nonlinear* feedback analysis and design rest. As an illustration, let us point out Kokotovic’s recent survey paper [10], intended as a summary of current work and future directions on nonlinear design, in which the notion of ISS plays a central unifying concept. Several current textbooks and monographs, including [12], [13], [14], [21], make use of the ISS notion and results, sometimes in an essential manner.

Applications of input to state stability are now widespread. Besides the many applications to recursive design in the above-mentioned books, let us merely cite a few

D. Angeli is with the Dip. Sistemi e Informatica, University of Florence, 50139 Firenze, Italy. E-mail: angeli@dsi.unifi.it

E.D. Sontag is with the Department of Mathematics, Rutgers University, New Brunswick, NJ 08903, USA. E-mail: sontag@hilbert.rutgers.edu. Work was supported in part by US Air Force Grant F49620-98-1-0242

Y. Wang is with the Department of Mathematics, Florida Atlantic University, Boca Raton, FL 33431, USA. E-mail: ywang@math.fau.edu. Work was supported in part by NSF Grant DMS-9457826

additional references: singular perturbation analysis [3], powerful global small-gain theorems [11], foundations of tracking design [19], supervisory/switching adaptive control [6], observers [8], almost-disturbance decoupling for non minimum-phase systems [9], and feedback stabilization with bounded controllers [29]. Moreover, this concept has many equivalent versions, which indicates that it is mathematically natural: there are characterizations in terms of dissipation, robustness margins, and classical Lyapunov-like functions; see e.g. [25], [26].

As remarked in [24], input-to-state stability is a nonlinear generalization both of finite gain with respect to supremum norms and of finite L^2 gain (“nonlinear H^∞ ”); this property takes account of initial states in a manner fully compatible with classical Lyapunov stability, and replaces finite linear gains, which represent far too strong a requirement for general nonlinear operators, with “nonlinear gains”.

A system which is ISS exhibits low overshoot and low total energy response when excited by uniformly bounded or energy-bounded signals respectively. These are highly desirable qualitative characteristics. However, it is sometimes the case that feedback design does *not* render ISS behavior, or that only a weaker property than ISS is verified in a step in recursive design.

One such weaker, but still very meaningful, property was given the name of *integral* input to state stability, iISS for short, in the recent paper [24]. This property reflects the qualitative property of *small overshoot when disturbances have finite energy*, and provides a qualitative analog of “finite H^2 norm” for linear systems. This is a property with obvious physical significance and relevance. The paper [24] showed that iISS is, in general, strictly weaker than ISS, and provided a very conservative Lyapunov-type sufficient condition. The present paper provides several foundational results, showing that the iISS property is a most natural one to be expected for well-behaved nonlinear systems, being equivalent to the combination of well-known dissipation and detectability properties, and admitting elegant Lyapunov-theoretic characterizations. We are confident that, once that the results in this paper become more widely known, iISS will play a role at least as prominent as the one that ISS currently has.

In fact, the notion of iISS, and the results in this paper, which were previously announced in electronic preprint form, have already played a role in several recent control works. For example, the iISS property appears in the latest approaches to supervisory design in adaptive control. In the paper [7], Hespanha and Morse — citing preprints of this work — studied the closed-loop system obtained

when a high-level supervisor directs the switching among a family of candidate controllers for an uncertain plant. Their convergence analysis was based on the assumption that each controller stabilizes the respective plant in an iISS sense with respect to an input which is related to a measure of estimator performance, their motivation being that it is natural to define performance signals using integrals of output estimation errors. Another example of the use of the iISS concept can be found in the recent work of Liberzon [15], who approached the task of achieving disturbance attenuation in the iISS sense for nonlinear systems using bounded controls. He derived a universal formula based on hysteresis switching, in the context in particular of switched and hybrid systems. The notion of integral input to state stability played a key role in this work. Yet another direct motivation for the study of the iISS property is as follows.

Tracking Problems

In the paper [19], Marino and Tomei proposed the reformulation of tracking problems by means of the notion of input to state stability. Their goal was to strengthen the robustness properties of tracking designs, and they found the notion of ISS to be instrumental in the precise characterization of performance. In fact, they emphasized the novelty of using the ISS notion in this role. It turns out, however, that a typical passivity-based tracking design may well *not* result in ISS behavior, as we illustrate now by means of an example in robotic control.

Consider the manipulator shown in Fig. 1. A simple

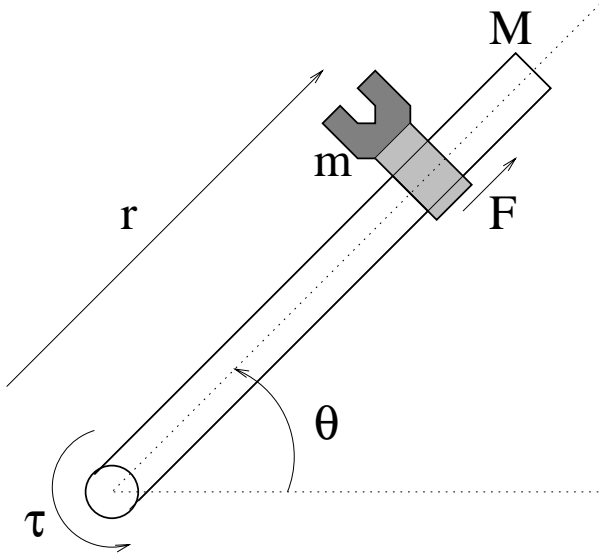

Fig. 1. A Manipulator

model is obtained considering the arm as a segment with mass M and length L , and the hand as a material point with mass m . If we denote with r the position of the hand and with θ the angle of the arm, the equations for such a system are:

$$\begin{aligned} (mr^2 + ML^2/3) \ddot{\theta} + 2mrr\dot{\theta} &= \tau \\ m\ddot{r} - mr\dot{\theta}^2 &= F, \end{aligned} \quad (1)$$

where F and τ indicate external torques. We now study the closed-loop system which is obtained by choosing τ and F as:

$$\begin{aligned} \tau &= -k_{d_1}\dot{\theta} - k_{p_1}(\theta - \theta_d) \\ F &= -k_{d_2}\dot{r} - k_{p_2}(r - r_d), \end{aligned} \quad (2)$$

with $k_{p_1}, k_{p_2}, k_{d_1}, k_{d_2} > 0$. (For notational simplicity, we will also write $q = [\theta, r]^T$). This represents a typical passivity-based tracking design, when we think of r_d and θ_d as signals to be followed by r and θ .

Normally, one establishes tracking behavior, as well as the closed-loop stability of the system when the reference signal $q_d = (\theta_d, r_d)$ is constant; for such signals, one obtains $q' \rightarrow 0$ and $q \rightarrow q_d$ as $t \rightarrow +\infty$. In the spirit of input-to-state stability, however, it is natural to ask what is the sensitivity of the design to *additive measurement noise*. That is, suppose that the input applied to the system is, instead of (2):

$$\begin{aligned} \tau &= -k_{d_1}(\dot{\theta} + d_{11}) - k_{p_1}(\theta + d_{12} - \theta_d) \\ F &= -k_{d_2}(\dot{r} + d_{21}) - k_{p_2}(r + d_{22} - r_d), \end{aligned}$$

where the $d_{ij}(t)$'s are observation errors. The closed-loop system that results is then as follows:

$$\begin{aligned} (mr^2 + ML^2/3)\ddot{\theta} + 2mrr\dot{\theta} &= u_1 - k_{d_1}\dot{\theta} - k_{p_1}\theta \\ u_2m\ddot{r} - mr\dot{\theta}^2 &= u_2 - k_{d_2}\dot{r} - k_{p_2}r, \end{aligned} \quad (3)$$

or equivalently, in classical first-order control system form (denoting \dot{q} by z),

$$\begin{aligned} \dot{q}_1 &= z_1, \\ \dot{q}_2 &= z_2, \\ \dot{z}_1 &= \frac{-2mq_2z_1z_2 - k_{p_1}q_1 - k_{d_1}z_1}{mq_2^2 + ML^2/3} + \frac{k_{p_1}u_1}{mq_2^2 + ML^2/3}, \\ \dot{z}_2 &= q_2z_1^2 - \frac{k_{p_2}q_2}{m} - \frac{k_{d_2}z_2}{m} + \frac{k_{p_2}u_2}{m}, \end{aligned} \quad (4)$$

where

$$u_1 = -k_{d_1}d_{11} - k_{p_1}(d_{12} - \theta_d)$$

and

$$u_2 = -k_{d_2}d_{21} - k_{p_2}(d_{22} - r_d)$$

can be thought of as external inputs to the closed-loop system.

The goal stated earlier is to qualitatively analyze the sensitivity of the full state (q, z) as a function of the measurement errors d_{ij} . As these errors are potentially arbitrary functions, this problem amounts to the study of stability properties with respect to arbitrary input functions $u = (u_1, u_2)$.

It is worth pointing out that we are led to exactly *the same mathematical problem* if interested, instead, in another very obvious question, namely, in the analysis of the behavior of the state (q, z) in response to attempts to follow *time-varying tracking signals*, even in the absence of observation errors. Indeed, in that case the d_{ij} 's would be zero, but the different possible tracking functions θ_d and r_d would still give rise to potentially arbitrary inputs u_1 and u_2 . In summary, either of these two basic control questions: sensitivity to measurement error, or analysis of

time-varying (instead of merely constant) tracking signals, gives rise to the problem of studying stability of the system with respect to the inputs u .

As in current nonlinear control studies, and specifically as in [19] for tracking problems, one may ask then if the system (4) is ISS when u is taken as an input. (The authors of [19] required tracking controllers to have an ISS property with respect to disturbances acting on the system. In the special case when the disturbances are matched to the control, this amounts to the problem studied here.) In particular, if the system were to be ISS, then bounded inputs u should result in bounded trajectories (ISS is a stronger property than “bounded-input bounded-state” stability). However, there are bounded inputs which produce *nonlinear resonance* behavior, resulting in unbounded state trajectories, which implies that this system is not ISS. Indeed, the input shown in Figure 2 has the property that, for a

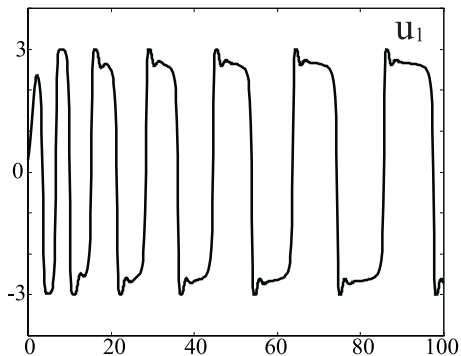

Fig. 2. Input Signal

suitable initial state, the ensuing trajectory is unbounded. Figure 3 shows the “ r ” component of the state of a certain solution which corresponds to this input (in Appendix A-C,

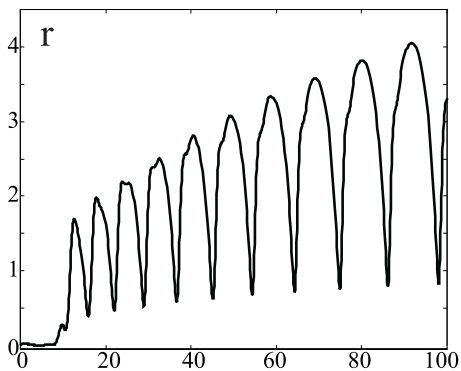

Fig. 3. Nonlinear Resonance

we explain how this input and trajectory were calculated).

In conclusion, the tracking system behavior exhibits unstable behavior with respect to measurement disturbances and/or with respect to time-varying reference signals. One might hope, however, given the simplicity and common use of these designs, that *some sort of robustness property is verified* for this system. The study of this question, for this example, led to the work reported in the present paper. The answer turns out to have wide applicability. We

discovered that the weaker but still very useful property of iISS is always satisfied for the passivity controller in our robotic example, even though ISS is not. This property is defined precisely in the next section; after stating the main results, we will show why it holds for the example.

Outline of Paper

In this paper, we provide a complete, necessary and sufficient, Lyapunov-like characterization of the iISS property. Just as the equivalences for ISS, which have found wide applicability and serve to justify the ISS concept, are derived from its Lyapunov characterization, we expect that the current paper will be the first step in the understanding of which system properties are equivalent to iISS. In addition, the characterizations allow one to consider “LaSalle” types of dissipation inequalities (semidefinite derivatives), filling-in a theoretical gap in the ISS literature.

Section II discusses the main concepts and states the main results. It also explains how the notion presented here represents the obvious generalization of “finite H^2 gain” under nonlinear coordinate changes. After that, we return, in Section III, to the robotics example discussed earlier, and we verify, using the characterizations presented in the paper, why the system indeed satisfies the iISS property. Then, in Section IV, we provide the main proofs of this paper. In Section V, we provide a counterexample to the conjecture (which would seem true at first) that iISS might be equivalent to simply forward completeness plus 0-GAS. Section VI discusses several related remarks for dual notions of observability. Section VII summarizes the conclusions of the paper. Finally, the Appendix collects some technical lemmas and the details on the numerical calculations that led to Figures 2 and 3.

II. DEFINITIONS AND STATEMENTS OF MAIN RESULTS

Consider the system

$$\dot{x} = f(x, u) \quad (5)$$

with states $x(t)$ evolving in Euclidean space \mathbb{R}^n . Here, controls (or inputs) are measurable and locally essentially bounded functions $u : \mathbb{R}_{\geq 0} \rightarrow \mathbb{R}^m$, and $f : \mathbb{R}^n \times \mathbb{R}^m \rightarrow \mathbb{R}^n$ is assumed to be locally Lipschitz.

Given any control u and any $\xi \in \mathbb{R}^n$, there is a unique maximal solution of the initial value problem $\dot{x} = f(x, u)$, $x(0) = \xi$. This solution is defined on some maximal open interval, and it is denoted by $x(\cdot, \xi, u)$.

Definition II.1: ([24]) System (5) is *integral input-to-state stable* (iISS) if there exist functions* $\alpha \in \mathcal{K}_\infty$, $\beta \in \mathcal{KL}$, and $\gamma \in \mathcal{K}$, such that, for all $\xi \in \mathbb{R}^n$ and all u , the solution

*We use standard terminology, cf. [5]: \mathcal{K} is the class of functions $[0, \infty) \rightarrow [0, \infty)$ which are zero at zero, strictly increasing, and continuous, \mathcal{K}_∞ is the subset of \mathcal{K} functions that are unbounded, \mathcal{L} is the set of functions $[0, +\infty) \rightarrow [0, +\infty)$ which are continuous, decreasing, and converging to 0 as their argument tends to $+\infty$, \mathcal{KL} is the class of functions $[0, \infty)^2 \rightarrow [0, \infty)$ which are class \mathcal{K} on the first argument and class \mathcal{L} on the second argument. A positive definite function $[0, \infty) \rightarrow [0, \infty)$ is one that is zero at 0 and positive otherwise.

$x(t, \xi, u)$ is defined for all $t \geq 0$, and

$$\alpha(|x(t, \xi, u)|) \leq \beta(|\xi|, t) + \int_0^t \gamma(|u(s)|) ds \quad (6)$$

for all $t \geq 0$, where $|\cdot|$ denotes the standard Euclidean norm. \square

Observe that a system is iISS if and only if there exist functions $\beta \in \mathcal{KL}$ and $\gamma_1, \gamma_2 \in \mathcal{K}$ such that

$$|x(t, \xi, u)| \leq \beta(|\xi|, t) + \gamma_1 \left(\int_0^t \gamma_2(|u(s)|) ds \right) \quad (7)$$

for all $t \geq 0$, all $\xi \in \mathbb{R}^n$, and all u .

Also note that if system (5) is iISS, then it is 0-GAS, that is, the 0-input system

$$\dot{x} = f(x, 0)$$

is globally asymptotically stable (GAS). (That is, the zero solution of this system is globally asymptotically stable.)

Definition II.2: A continuously differentiable function $V : \mathbb{R}^n \rightarrow \mathbb{R}$ is called an *iISS-Lyapunov function* for system (5) if there exist functions $\alpha_1, \alpha_2 \in \mathcal{K}_\infty$, $\sigma \in \mathcal{K}$, and a continuous positive definite function α_3 , such that

$$\alpha_1(|\xi|) \leq V(\xi) \leq \alpha_2(|\xi|) \quad (8)$$

for all $\xi \in \mathbb{R}^n$, and

$$DV(\xi)f(\xi, \mu) \leq -\alpha_3(|\xi|) + \sigma(|\mu|) \quad (9)$$

for all $\xi \in \mathbb{R}^n$ and all $\mu \in \mathbb{R}^m$. \square

Note that the estimate (8) amounts to the requirement that V must be positive definite (i.e., $V(x) > 0$ for all $x \neq 0$ and $V(0) = 0$), and proper (i.e, radially unbounded, namely, $V(x) \rightarrow \infty$ as $|x| \rightarrow \infty$).

Notice the difference between Definition II.2 and the dissipation characterization of ISS (cf. [25], [26]): *the ISS property is equivalent to the existence of a V as here but for which α_3 is required to be unbounded (in fact, class \mathcal{K}_∞).* As an example, consider the one dimensional system:

$$\dot{x} = -\arctan x + u.$$

Let $V(x) = x \arctan x$. Then, $DV(\xi)f(\xi, \mu)$ equals $\arctan \xi (-\arctan \xi + \mu) + \frac{\xi}{1+\xi^2}(-\arctan \xi + \mu)$, which is $\leq -(\arctan |\xi|)^2 + 2|\mu|$, showing that V is an iISS-Lyapunov function for the system. But in the estimate (9) we have $\alpha_3(r) = (\arctan r)^2$, which is not of class \mathcal{K}_∞ , so one does not have an ISS-type estimate. Indeed, this system does not admit any ISS-Lyapunov function, since the system is not ISS (the trajectory with $x(0) = 1$ and $u(t) \equiv \pi/2$ is unbounded).

Our main result will establish that the existence of a smooth iISS-Lyapunov function is necessary as well as sufficient for the system to be iISS.

This fact will be stated in several essentially equivalent ways. One possibility is to relax the positive definiteness requirement on α_3 to just nonnegativity, or simply omit it, but to assume explicitly that the system is 0-GAS.

Another possibility is to deduce the 0-GAS property from LaSalle's invariance principle. This last variant is of considerable interest in applications such as the robotics example discussed in Section III, and it may be stated using concepts of detectability, as is by now standard in the nonlinear dissipation literature (see, e.g. [30], section 3.2). Let us say that an *output* for the system (5) is a continuous map $h : \mathbb{R}^n \rightarrow \mathbb{R}^p$ (for some p), with $h(0) = 0$. For each initial state $\xi \in \mathbb{R}^n$, and each input u , we let $y(t, \xi, u)$ be the corresponding output function, i.e., $y(t, \xi, u) = h(x(t, \xi, u))$ (defined on some maximal interval $[0, T_{\xi, u})$). The system (5) with output h is said to be *weakly zero-detectable* if, for each ξ such that $T_{\xi, 0} = \infty$ and $y(t, \xi, 0) \equiv 0$, it must be the case that $x(t, \xi, 0) \rightarrow 0$ as $t \rightarrow \infty$. Finally, we will say for the purposes of this paper that the system (5) with output h is *dissipative* if there exists a continuously differentiable, proper, and positive definite function V (a *storage function* for the system), together with a $\sigma \in \mathcal{K}$ and a continuous positive definite function α_4 , such that

$$DV(\xi)f(\xi, \mu) \leq -\alpha_4(|h(\xi)|) + \sigma(|\mu|) \quad (10)$$

for all $\xi \in \mathbb{R}^n$ and all $\mu \in \mathbb{R}^m$. If this property holds with a V which is also smooth, we say that the system (5) with output h is *smoothly dissipative*. Finally, if (10) holds with $h = 0$, i.e., if there exists a (smooth) proper and positive definite V , and a $\sigma \in \mathcal{K}$, so that

$$DV(\xi)f(\xi, \mu) \leq \sigma(|\mu|) \quad (11)$$

holds for all $\xi \in \mathbb{R}^n$ and all $\mu \in \mathbb{R}^m$, we say that the system (5) is *zero-output (smoothly) dissipative*.

We are now able to state the main conclusions of this paper.

Theorem 1: For any system (5), the following properties are equivalent:

1. The system is iISS.
2. The system admits a smooth iISS-Lyapunov function.
3. There is some output which makes the system smoothly dissipative and weakly zero-detectable.
4. The system is 0-GAS and zero-output smoothly dissipative.

The main step of the proof of Theorem 1 is given in Section IV, where we show $1 \Leftrightarrow 2$ and also we prove Proposition II.5 (see below), which characterizes the 0-GAS property. The implication $4 \Rightarrow 2$ will be immediate from Proposition II.5. The remaining implications are routine, so we can dispose of them immediately, as follows. First of all, notice that $2 \Rightarrow 3$. To see this, take the iISS-Lyapunov function V as a storage function, and consider the inequality in (9). We introduce the output function $h(x) := \alpha_3(|x|)$. The system is weakly zero-detectable (in fact, it is even "zero-observable"), because $h(x) = 0$ implies $x = 0$, since α_3 is positive definite. Moreover, with α_4 equal to the identity, we have that $\alpha_4(|h(\xi)|) = \alpha_3(|\xi|)$, so (10) is the same as (9). Finally, we show that $3 \Rightarrow 4$. Suppose that (10) holds. With $\mu = 0$, we take V as a Lyapunov function for the zero-input system $\dot{x} = f(x, 0)$. The zero-detectability condition means that the LaSalle invariance principle, with

the Lyapunov function V , can be applied, and we conclude 0-GAS. And since $-\alpha_4(h(\xi)) \leq 0$, also (11) holds.

Remark II.3: We stated Theorem 1 requiring that the corresponding functions V (iISS-Lyapunov, storage) be smooth, that is, infinitely differentiable. This makes the existence of such V 's, which is the hardest part to prove, more interesting. The sufficiency parts of the proofs do not require smoothness, however. In other words, system (5) is iISS if it admits an iISS-Lyapunov function, or if it has an output which makes the system dissipative and weakly zero-detectable or if it is 0-GAS and zero-output dissipative. \square

Remark II.4: We used the adjective “weak” when defining zero-detectability in order to distinguish this notion from true detectability, or “(zero-input) output to state stability”, cf. [27] and also Section VI below, where one asks that “small output (when $u \equiv 0$) implies small state”, as opposed to merely asking that “zero output implies small state” as here. \square

A Characterization of 0-GAS Control Systems

In the proof Theorem 1, we utilize the following characterization of 0-GAS systems. It is in itself a result of some interest.

We call a positive definite function $W : \mathbb{R}^n \rightarrow \mathbb{R}_{\geq 0}$ *semi-proper* if there exist a function $\pi(\cdot)$ of class \mathcal{K} and a proper positive definite function W_0 such that $W = \pi \circ W_0$. (It is easy to see that a continuous positive definite $V : \mathbb{R}^n \rightarrow \mathbb{R}_{\geq 0}$ is semiproper if and only if, for each r in the range of V , the sublevel set $\{x \mid V(x) \leq r\}$ is compact.)

Proposition II.5: System (5) is 0-GAS if and only if there exist a smooth semi-proper function W , a $\sigma \in \mathcal{K}$, and a continuous positive definite function $\rho : \mathbb{R}_{\geq 0} \rightarrow \mathbb{R}_{\geq 0}$, such that

$$DW(\xi)f(\xi, \mu) \leq -\rho(|\xi|) + \sigma(|\mu|) \quad (12)$$

for all $\xi \in \mathbb{R}^n$ and all $\mu \in \mathbb{R}^m$.

The sufficiency part follows from the standard Lyapunov results for autonomous systems: if (12) holds with $W = \pi \circ W_0$, then W_0 is a Lyapunov function for the 0-input system. (This is because (12) implies that $DW_0(\xi)f(\xi, 0) < 0$ for all $\xi \neq 0$.) The necessity implication will be proved in Section IV.

Proof of 4 \Rightarrow 2 in Theorem 1. Let the functions V and σ be so that (11) holds. Since the system is 0-GAS, by Proposition II.5, there exists a smooth semi-proper, positive definite function V_0 such that

$$DV_0(\xi)f(\xi, \mu) \leq -\rho_0(\xi) + \sigma_0(|\mu|), \quad \forall \xi \in \mathbb{R}^n, \quad \forall \mu \in \mathbb{R}^m$$

for some continuous positive definite function ρ_0 and some \mathcal{K} -function σ_0 . Let $V_1(\xi) = V(\xi) + V_0(\xi)$. It then clear that V_1 is an iISS-Lyapunov function: it is proper because V_0 is, and

$$D(V + V_0)(\xi)f(\xi, \mu) \leq -\rho_0(\xi) + \sigma_0(|\mu|) + \sigma(|\mu|)$$

gives an estimate as in (9). \blacksquare

Motivation: Finite-Gain under Coordinate Changes

As mentioned in the Introduction, we wish to explain briefly how the notion of iISS arises in an extremely natural manner when generalizing linear L^2 to L^∞ gains (sometimes called “ H^2 gains”) to nonlinear systems. (See also [24], which explains why, when we apply the same reasoning to “ L^2 to L^2 stability” or to “ L^∞ to L^∞ stability,” we recover input to state stability, as well as [4] for more on changes of coordinates and ISS.)

For linear systems, one defines finite-gain stability, with respect to square norm on inputs and sup norm on states, by requiring the existence of constants c and λ , with $\lambda > 0$, so that, for each input $u(\cdot)$ and each initial state ξ , the solution $x(t)$ of $\dot{x} = Ax + Bu$, $x(0) = \xi$, satisfies the following estimate:

$$|x(t)| \leq ce^{-\lambda t} |\xi| + c \int_0^t |u(s)|^2 ds \quad \text{for all } t \geq 0. \quad (13)$$

(Actually, most textbooks omit the initial state, but this is the appropriate estimate if nonzero initial states are taken into account.) In a nonlinear context, it is natural to require that notions of stability should be invariant under (nonlinear) changes of variables. Let us see what this leads us to. Suppose that we take an origin-preserving state change of coordinates $x = T(z)$ and an origin-preserving change of variables $u = S(v)$. That is, $T : \mathbb{R}^n \rightarrow \mathbb{R}^n$ and $S : \mathbb{R}^m \rightarrow \mathbb{R}^m$ are invertible, and they, as well as their inverses, are continuous; furthermore, we suppose that $T(0) = 0$ and $S(0) = 0$. Then, there are two functions $\alpha_1, \alpha_2 \in \mathcal{K}_\infty$ so that

$$\alpha_1(|z|) \leq |T(z)| \leq \alpha_2(|z|)$$

for all $z \in \mathbb{R}^n$, and, similarly, we can write $|S(v)|^2 \leq \gamma(|v|)$ for each $v \in \mathbb{R}^m$, for some $\gamma \in \mathcal{K}_\infty$. Therefore, the estimate (13) gives us, in terms of z and v :

$$\alpha_1(|z(t)|) \leq ce^{-\lambda t} \alpha_2(|\zeta|) + c \int_0^t \gamma(|u(s)|)^2 ds \quad \forall t \geq 0,$$

when $x(t) = T(z(t))$ and $u(t) = S(v(t))$ for all t , and $\zeta = z(0) = T^{-1}(\xi)$. In other words,

$$|z(t)| \leq \beta(|\zeta|, t) + \alpha_1^{-1} \left(\int_0^t 2c\gamma(|u(s)|)^2 ds \right) \quad \forall t \geq 0,$$

where we let $\beta(r, t) := \alpha_1^{-1}(2c\alpha_2(r)e^{-\lambda t})$. This is precisely as in the estimate (7), except that β has what appears to be a very special form. Surprisingly, however, any $\mathcal{K}\mathcal{L}$ function β can be majorized by a function of this special form, see [24], so indeed one obtains the general notion of iISS with this reasoning.

III. THE ROBOTICS EXAMPLE IS ISS

In this section we verify the iISS property for the robotics system (3) discussed earlier. (The same example was used, for a different purpose — namely, to illustrate a *different* nonlinear tracking design which produces ISS, as opposed to

merely iISS, behavior — in the paper [1].) One interesting feature of this example, which in fact motivated much of the research reported here, is that it illustrates the use of the LaSalle-type condition that we obtained.

To prove the iISS property, we introduce, as usual for mechanical manipulators, the following matrix notation:

$$H(q) = \begin{bmatrix} mr^2 + M\frac{L^2}{3} & 0 \\ 0 & m \end{bmatrix}, \quad C(q, \dot{q}) = mr \begin{bmatrix} \dot{r} & \dot{\theta} \\ -\dot{\theta} & 0 \end{bmatrix}$$

where $H(q)$ is the inertia matrix, and $C(q, \dot{q})$ expresses the Coriolis torques. Then (3) can be rewritten as

$$H(q)\ddot{q} + C(q, \dot{q})\dot{q} = -K_p(q - q_d) - K_d\dot{q},$$

where $K_p = \text{diag}\{k_{p_1}, k_{p_2}\}$, $K_d = \text{diag}\{k_{d_1}, k_{d_2}\}$, and $q_d = [\theta_d, r_d]^T$. We take the mechanical energy of the system as a candidate Lyapunov function:

$$V(q, z) = \frac{z^T H(q)z + q^T K_p q}{2} = \frac{\dot{q}^T H(q)\dot{q} + q^T K_p q}{2}. \quad (14)$$

Taking derivatives in (14) with respect to time along trajectories of (3) yields the following passivity-type estimate for $\frac{d}{dt}V(q(t), z(t))$:

$$\begin{aligned} & \dot{q}(t)^T H(q(t))\ddot{q}(t) + \frac{1}{2}\dot{q}(t)^T \overline{H(q(t))} \dot{q}(t) + q(t)^T K_p \dot{q}(t) \\ &= -\dot{q}(t)^T K_d \dot{q}(t) + \dot{q}(t)^T K_p q_d(t) \\ &\leq -c_1 |\dot{q}(t)|^2 + c_2 |q_d(t)|^2 = -c_1 |z(t)|^2 + c_2 |u(t)|^2, \end{aligned} \quad (15)$$

for some sufficiently small number $c_1 > 0$ and some sufficiently large number $c_2 > 0$. Inspection of the equations shows that, when $u \equiv 0$ and $z \equiv 0$, necessarily $q \equiv 0$ as well. Thus, thinking of z as an output, the system is weakly zero-detectable and dissipative; applying Theorem 1, one concludes that the system is iISS.

IV. MAIN PROOFS

The following Lemma will be needed several times during the proofs.

Lemma IV.1: Let $\rho : \mathbb{R}_{\geq 0} \rightarrow \mathbb{R}_{\geq 0}$ be a continuous positive definite function. Then there exist $\rho_1 \in \mathcal{K}_\infty$ and $\rho_2 \in \mathcal{L}$ such that:

$$\rho(r) \geq \rho_1(r) \rho_2(r). \quad (16)$$

The Lemma will be proved in the appendix; it is used in establishing the following comparison theorem.

Lemma IV.2: Given any continuous positive definite function $\rho : \mathbb{R}_{\geq 0} \rightarrow \mathbb{R}_{\geq 0}$, there exists a \mathcal{KL} -function β with the following property. Suppose that for some $0 < \tilde{t} \leq \infty$,

$$v : [0, \tilde{t}] \rightarrow \mathbb{R}_{\geq 0} \quad \text{and} \quad y : [0, \tilde{t}] \rightarrow \mathbb{R}$$

are, respectively, a continuous and a (locally) absolutely continuous function with $y(0) \geq 0$. Assume further that

$$\dot{y}(t) \leq -\rho(\max\{y(t) + v(t), 0\}) \quad (17)$$

holds for almost all $t \in [0, \tilde{t}]$. Then, letting $\|v_t\|_\infty$ be the supremum of the restriction of v to the interval $[0, t]$, the following estimate holds:

$$y(t) \leq \max\{\beta(y(0), t), \|v_t\|_\infty\} \quad \text{for all } t \in [0, \tilde{t}]. \quad (18)$$

Proof: We start by picking $\rho_1 \in \mathcal{K}$, $\rho_2 \in \mathcal{L}$ as in Lemma IV.1, for the function ρ . Without loss of generality, we may assume that ρ_1 and ρ_2 are locally Lipschitz. Otherwise, we may always pick locally Lipschitz functions $\tilde{\rho}_1 \in \mathcal{K}$ and $\tilde{\rho}_2 \in \mathcal{L}$ that are majorized by ρ_1 and ρ_2 respectively to replace ρ_1 and ρ_2 respectively.

A standard comparison principle asserts the existence of a function $\beta \in \mathcal{KL}$ having the following property: if $q : [0, T] \rightarrow \mathbb{R}_{\geq 0}$ is any absolutely continuous function that satisfies the differential inequality $\dot{q} \leq -\rho_1(q)\rho_2(2q)$ almost everywhere, then it must be the case that $q(t) \leq \beta(q(0), t)$ for all $t \in [0, T]$. (See for instance Lemma 4.4 in [16]; the statement in that reference applies to q defined on all of $[0, \infty)$, but exactly the same proof works for a finite interval. One choice for $\beta(s, t)$ is $\beta(s, t) = z(t)$, where z is the solution of the scalar initial value problem $\dot{z} = -\rho_1(z)\rho_2(2z)$, $z(0) = s$.)

Let now v and y be as in the statement of the Lemma, and define

$$t_0 := \min\{t \geq 0 \mid y(t) \leq \|v_t\|_\infty\}$$

(with $t_0 := \tilde{t}$ if $y(t) > \|v_t\|_\infty$ for all $t \in [0, \tilde{t}]$). For all $t \geq t_0$ (if $t_0 < \tilde{t}$), $y(t) \leq \|v_t\|_\infty$ (because y is nonincreasing, since $\dot{y}(t) \leq 0$ for all t , and $s \mapsto \|v_s\|_\infty$ is nondecreasing), so (18) holds for all $t \geq t_0$.

Pick now any $t \in [0, t_0]$. We have then that $y(t) > \|v_t\|_\infty \geq v(\tau)$ for all $\tau \in [0, t]$ (the last inequality by definition of $\|v_t\|_\infty$). Since y is nonincreasing, this means that also $y(\tau) \geq y(t) > v(\tau)$ for all such τ . Therefore

$$0 \leq y(\tau) \leq y(\tau) + v(\tau) \leq 2y(\tau)$$

for all $\tau \in [0, t]$. From (17) and the fact that ρ_1 is nondecreasing, we conclude that

$$\dot{y} \leq -\rho_1(y) \rho_2(2y) \quad (19)$$

almost everywhere on $[0, t]$. Since $t \in [0, t_0]$ was arbitrary, (19) holds on $[0, t_0]$ a.e. By the choice of β , it follows that $y(t) \leq \beta(y(0), t)$ for all $t \in [0, t_0]$. Thus (18) holds for all such t as well. ■

The following is a consequence of Lemma IV.2.

Corollary IV.3: Given any continuous positive definite function $\rho : \mathbb{R}_{\geq 0} \rightarrow \mathbb{R}_{\geq 0}$, there exists a \mathcal{KL} -function β with the following property. For any $0 < \tilde{t} \leq \infty$, and for any (locally) absolutely continuous function $y : [0, \tilde{t}] \rightarrow \mathbb{R}_{\geq 0}$ and any measurable, locally essentially bounded function $v : [0, \tilde{t}] \rightarrow \mathbb{R}_{\geq 0}$, if

$$\dot{y}(t) \leq -\rho(y(t)) + v(t) \quad (20)$$

holds for almost all $t \in [0, \tilde{t}]$, then the following estimate holds:

$$y(t) \leq \beta(y(0), t) + \int_0^t 2v(s) ds \quad \text{for all } t \in [0, \tilde{t}]. \quad (21)$$

Proof: First observe that one may always assume that the function ρ is locally Lipschitz, for otherwise one may replace ρ by any such function majorized by ρ . Take now any y, v as in the statement, and consider the solution $w(t)$ to the following initial value problem:

$$\dot{w}(t) = -\rho(|w(t)|) + v(t), \quad w(0) = y(0).$$

It follows from the standard comparison principle that $0 \leq y(t) \leq w(t)$ for all $t \in [0, \tilde{t}]$. In particular, we can write $\rho(w(t))$ instead of $\rho(|w(t)|)$ in the above equation. Now define v_1 and w_1 as follows:

$$v_1(t) = \int_0^t v(s) ds, \quad w_1(t) = w(t) - v_1(t).$$

Taking the derivative of w_1 with respect to t yields

$$\dot{w}_1(t) = -\rho(w(t)) = -\rho(\max\{w_1(t) + v_1(t), 0\})$$

for almost all $t \in [0, \tilde{t}]$, where the last equation holds because w is nonnegative. Let β be a \mathcal{KL} -function as in Lemma IV.2 for this ρ . It follows that

$$w_1(t) \leq \max\{\beta(w_1(0), t), \|v_{1t}\|_\infty\} \quad \forall t \in [0, \tilde{t}],$$

from which it follows that

$$\begin{aligned} y(t) \leq w(t) &\leq \beta(w(0), t) + \|v_{1t}\|_\infty + \int_0^t v(s) ds \\ &= \beta(y(0), t) + \int_0^t 2v(s) ds \end{aligned}$$

for all $t \in [0, \tilde{t}]$. \blacksquare

We also need the following result in our proofs.

Let \mathcal{N} denote the class of all functions $k : \mathbb{R} \rightarrow \mathbb{R}$ that are:

1. nondecreasing,
2. continuous, and
3. unbounded below (i.e., $\inf_{x \in \mathbb{R}} k(x) = -\infty$).

We will prove:

Proposition IV.4: Suppose that $c : \mathbb{R}^2 \rightarrow \mathbb{R}$ is such that $c(\cdot, y) \in \mathcal{N}$ for each $y \in \mathbb{R}$ and $c(x, \cdot) \in \mathcal{N}$ for each $x \in \mathbb{R}$. Then, there exists some function $k \in \mathcal{N}$ such that

$$c(x, y) \leq k(x) + k(y)$$

for all $(x, y) \in \mathbb{R}^2$.

This result generalizes the one given in [24], which applied only to functions of the form $c(x, y) = g(x + y)$ with $g \in \mathcal{N}$. We will need the ‘‘exponential’’ form of this result, which is as follows:

Corollary IV.5: Suppose that $\gamma : \mathbb{R}_{\geq 0}^2 \rightarrow \mathbb{R}$ is such that $\gamma(\cdot, s) \in \mathcal{K}$ for each $s \in \mathbb{R}_{\geq 0}$ and $\gamma(r, \cdot) \in \mathcal{K}$ for each $r \in \mathbb{R}_{\geq 0}$. Then, there exists some function $\sigma \in \mathcal{K}$ such that

$$\gamma(r, s) \leq \sigma(r) \sigma(s)$$

for all $(x, y) \in (\mathbb{R}_{\geq 0})^2$.

Proof: Consider $c(x, y) := \ln \gamma(e^x, e^y)$; then c is a class \mathcal{N} function with respect to both arguments. Let $k \in \mathcal{N}$ be

as in Proposition IV.4; without loss of generality, we may assume that k is strictly increasing. Then $\sigma(r) := e^{k(\ln r)}$ (and $\sigma(0) = 0$) establishes the Corollary. \blacksquare

The proof of Proposition IV.4 will be given in the appendix.

Proof of 2 \Rightarrow 1 in Theorem 1

We first prove that existence of a (just continuously differentiable, cf. Remark II.3) iISS-Lyapunov function V implies iISS. So pick V so that (8)-(9) hold. Let $\rho_1 \in \mathcal{K}_\infty$ and $\rho_2 \in \mathcal{L}$ be functions as in Lemma IV.1 for α_3 . We let $\tilde{\rho}$ be any positive definite function which is locally Lipschitz and satisfies

$$\tilde{\rho}(r) \leq \rho_1(\alpha_2^{-1}(r)) \rho_2(\alpha_1^{-1}(r))$$

for all $r \geq 0$. By equation (8) we have:

$$\begin{aligned} DV(\xi) f(\xi, \mu) &\leq -\rho_1(|\xi|) \rho_2(|\xi|) + \sigma(|\mu|) \\ &\leq -\tilde{\rho}(V(\xi)) + \sigma(|\mu|) \end{aligned} \quad (22)$$

for all ξ and μ .

Now pick any trajectory $x(\cdot)$ corresponding to a control $u(\cdot)$. Equation (22) says that

$$\dot{V}(x(t)) \leq -\tilde{\rho}(V(x(t))) + \sigma(|u(t)|)$$

for almost all t . We let β be associated to $\tilde{\rho}$ as in Corollary IV.3. It then holds that

$$V(x(t)) \leq \beta(V(x(0)), t) + \int_0^t 2\sigma(|u(s)|) ds$$

for all $t \geq 0$. Hence,

$$\begin{aligned} \alpha_1(|x(t)|) &\leq V(x(t)) \\ &\leq \beta(V(0), t) + \int_0^t 2\sigma(|u(s)|) ds \\ &\leq \beta(\alpha_2(|x(0)|), t) + \int_0^t 2\sigma(|u(s)|) ds \end{aligned}$$

for all $t \geq 0$, and so the sufficiency proof is complete.

Proof of 1 \Rightarrow 2 in Theorem 1

We first remark that the proof of Lemma 3.1 in [16] can be used to show the following:

Lemma IV.6: For each given \mathcal{KL} -function β , there exists a family of mappings $\{T_r\}_{r>0}$ with:

- for each fixed $r > 0$, $T_r : \mathbb{R}_{>0} \xrightarrow{\text{onto}} \mathbb{R}_{>0}$ is continuous and is strictly decreasing;
 - for each fixed $\varepsilon > 0$, $T_r(\varepsilon)$ is (strictly) increasing as r increases and $\lim_{r \rightarrow \infty} T_r(\varepsilon) = \infty$;
- such that

$$\beta(s, t) < \varepsilon$$

for all $s \leq r$, all $t \geq T_r(\varepsilon)$. \square

Assume now that system (5) is iISS with α, β, γ as in Definition II.1. Let φ be any smooth \mathcal{K}_∞ -function such

that $\gamma(\varphi(s)) \leq \alpha(s)$ for all $s \geq 0$. Consider the following system:

$$\dot{x}(t) = f(x(t), d(t)\varphi(|x(t)|)), \quad (23)$$

where we restrict the inputs d , thought of here as ‘‘disturbances’’, to have values in the closed unit ball: $d(\cdot) : [0, \infty) \rightarrow \bar{B}$, where \bar{B} denotes the closed unit ball $\{\mu \in \mathbb{R}^m : |\mu| \leq 1\}$ in \mathbb{R}^m . We let \mathcal{M} denote the set of all such inputs, and we let $x_\varphi(t, \xi, d)$ denote the trajectory of (23) corresponding to the initial state ξ and the function d . This is defined on some maximal interval $[0, T_{\xi, d}^+)$ with $0 < T_{\xi, d}^+ \leq \infty$. It then follows from (6) that, for any given ξ, d , and each $t \in [0, T_{\xi, d}^+)$, and defining $\beta_0 := \beta(\cdot, 0)$:

$$\begin{aligned} \alpha(|x_\varphi(t, \xi, d)|) &\leq \beta(|\xi|, t) \\ &+ \int_0^t \gamma(|d(s)| \varphi(|x_\varphi(s, \xi, d)|)) ds \\ &\leq \beta_0(|\xi|) + \int_0^t \gamma(\varphi(|x_\varphi(s, \xi, d)|)) ds \\ &\leq \beta_0(|\xi|) + \int_0^t \alpha(|x_\varphi(s, \xi, d)|) ds. \end{aligned}$$

It thus follows, using Gronwall’s inequality, that

$$\alpha(|x_\varphi(t, \xi, d)|) \leq \beta_0(|\xi|) e^t$$

for all $0 \leq t < T_{\xi, d}^+$. Hence the maximal solution stays in a bounded set (the ball of radius $\beta_0(|\xi|) \exp(T_{\xi, d}^+)$) if $T_{\xi, d}^+ < \infty$. Thus, $T_{\xi, d}^+ = +\infty$. In conclusion:

Lemma IV.7: If system (5) is iISS, then there exists a smooth \mathcal{K}_∞ -function φ such that system (23) is forward complete, that is, $x_\varphi(t, \xi, d)$ is defined for all $t \geq 0$, all $\xi \in \mathbb{R}^n$, and all $d \in \mathcal{M}$. \square

Because of forward completeness, this follows from [16] (c.f. Propositions 5.1 and 5.5 of [16]):

Lemma IV.8: Assume system (5) is iISS, and let φ be given as in Lemma IV.7. For any fixed $T > 0$ and any compact $K \subset \mathbb{R}^n$, there is a compact $K_1 \subset \mathbb{R}^n$ such that $x_\varphi(t, \xi, d) \in K_1$ for all $t \in [0, T]$, all $\xi \in K$ and all $d \in \mathcal{M}$. Furthermore, there is a constant $C > 0$ (which only depends on T and the set K) such that

$$|x_\varphi(t, \xi, d) - x_\varphi(t, \eta, d)| \leq C |\xi - \eta|$$

for any $\xi, \eta \in K$, any $0 \leq t \leq T$, and any $d \in \mathcal{M}$. \square

We now continue with the proof of the implication $1 \Rightarrow 2$ of Theorem 1. Without loss of generality, one may assume that α is a smooth \mathcal{K}_∞ -function. Otherwise, one can always replace α by a smooth \mathcal{K}_∞ -function $\tilde{\alpha}$ majorized by α . We will first prove the result under the assumption that γ is a smooth \mathcal{K}_∞ -function, and then we show how to prove the result without this assumption.

Define $g : \mathbb{R}^n \rightarrow \mathbb{R}_{\geq 0}$ by

$$g(\xi) = \sup\{z(t, \xi, d) : t \geq 0, d \in \mathcal{M}\}, \quad (24)$$

where for each $\xi \in \mathbb{R}^n$ and $d \in \mathcal{M}$, $z(\cdot, \xi, d)$ is defined by

$$\begin{aligned} z(t, \xi, d) &= \alpha(|x_\varphi(t, \xi, u)|) \\ &- \int_0^t \gamma(|d(s)| \varphi(|x_\varphi(s, \xi, d)|)) ds. \end{aligned} \quad (25)$$

Note that this function is well defined, and

$$\alpha(|\xi|) \leq g(\xi) \leq \beta_0(|\xi|) \quad (26)$$

for all $\xi \in \mathbb{R}^n$. In particular, $g(0) = 0$.

Let $T_r(\varepsilon)$ be defined as in Lemma IV.6. Then one sees that if $0 < r_1 < |\xi| < r_2$, then

$$g(\xi) = \sup\{z(t, \xi, d) \mid 0 \leq t \leq T_{r_2}(\alpha(r_1)), d \in \mathcal{M}\}.$$

Lemma IV.9: The function g is locally Lipschitz on $\mathbb{R}^n \setminus \{0\}$ and continuous everywhere.

Proof: Fix any $\xi_0 \neq 0$, and let $s_0 = |\xi_0|$. Let $K_0 = \bar{B}(\xi_0, s_0/2)$, the closed ball centered at ξ_0 and with radius $s_0/2$. Let $T = T_{2s_0}(\alpha(s_0/2))$. Then

$$g(\xi) = \sup\{z(t, \xi, d) : t \in [0, T], d \in \mathcal{M}\}$$

for all $\xi \in K_0$. According to Lemma IV.8, one knows that there exists some $L > 0$ such that

$$|x_\varphi(t, \xi, d)| \leq L$$

for any $\xi \in K_0$, any $t \in [0, T]$, and any $d \in \mathcal{M}$. Since γ is smooth, and in particular locally Lipschitz, there exists $C_1 > 0$ such that

$$|\gamma(r_1) - \gamma(r_2)| \leq C_1 |r_1 - r_2|$$

for all $r_1, r_2 \in [0, L]$. Consequently,

$$\begin{aligned} &|\gamma(|d(s)| \varphi(|x_\varphi(s, \xi, d)|)) - \gamma(|d(s)| \varphi(|x_\varphi(s, \eta, d)|))| \\ &\leq C_1 |\varphi(|x_\varphi(s, \xi, d)|) - \varphi(|x_\varphi(s, \eta, d)|)| \end{aligned}$$

for all $\xi, \eta \in K_0$, all $t \in [0, T]$, and all $d \in \mathcal{M}$. Since α and φ are smooth, and $x_\varphi(s, \xi, d)$ is locally Lipschitz in ξ uniformly in $t \in [0, T]$ and in $d \in \mathcal{M}$ (this is what is asserted by the last statement in Lemma IV.8), there exists some C_2 such that

$$|\alpha(|x_\varphi(t, \xi, d)|) - \alpha(|x_\varphi(t, \eta, d)|)| \leq C_2 |\xi - \eta|,$$

and

$$|\varphi(|x_\varphi(s, \xi, d)|) - \varphi(|x_\varphi(s, \eta, d)|)| \leq C_2 |\xi - \eta|$$

for all $\xi, \eta \in K_0$, all $t \in [0, T]$, and all $d \in \mathcal{M}$. It then follows that the difference

$$\int_0^t \gamma(|d(s)| \varphi(|x_\varphi(s, \xi, d)|)) - \gamma(|d(s)| \varphi(|x_\varphi(s, \eta, d)|)) ds$$

is upper bounded in absolute value by $C_3 |\xi - \eta|$ for all $\xi, \eta \in K_0$, all $t \in [0, T]$, all $d \in \mathcal{M}$, where $C_3 = C_1 C_2 T$. This implies that

$$|z(t, \xi, d) - z(t, \eta, d)| \leq C_4 |\xi - \eta|$$

for all $\xi, \eta \in K_0$, all $t \in [0, T]$, all $d \in \mathcal{M}$, where $C_4 = C_2 + C_3$.

Pick any $\varepsilon > 0$. Then for each $\zeta \in K_0$, there is some $t_{\zeta, \varepsilon} \in [0, T]$ and $d_{\zeta, \varepsilon} \in \mathcal{M}$ such that

$$g(\zeta) \leq z(t_{\zeta, \varepsilon}, \zeta, d_{\zeta, \varepsilon}) + \varepsilon.$$

Let $\xi, \eta \in K_0$. Then

$$\begin{aligned} g(\xi) - g(\eta) &\leq z(t_{\xi, \varepsilon}, \xi, d_{\xi, \varepsilon}) + \varepsilon - z(t_{\xi, \varepsilon}, \eta, d_{\xi, \varepsilon}) \\ &\leq C_4 |\xi - \eta| + \varepsilon. \end{aligned} \quad (27)$$

Note that (27) holds for all $\varepsilon > 0$, so it follows that

$$g(\xi) - g(\eta) \leq C_4 |\xi - \eta|.$$

By symmetry, $g(\eta) - g(\xi) \leq C_4 |\xi - \eta|$. This proves that

$$|g(\xi) - g(\eta)| \leq C_4 |\xi - \eta|$$

for all $\xi, \eta \in K_0$. Thus, g is locally Lipschitz on $\mathbb{R}^n \setminus \{0\}$.

To show that g is continuous at $\xi = 0$, note that $g(0) = 0$, and $g(\xi) \leq \beta_0(\xi) \rightarrow 0$ as $\xi \rightarrow 0$. Thus g is continuous everywhere. \blacksquare

We next show that g cannot increase too fast along trajectories. Pick any $\xi \neq 0$, $h > 0$, and $|\mu| \leq 1$. Let d_μ denote the constant function $d(t) \equiv \mu$. Then

$$\begin{aligned} &g(x_\varphi(h, \xi, d_\mu)) \\ &= \sup_{t \geq 0, d \in \mathcal{M}} \left\{ \alpha(|x_\varphi(t, x_\varphi(h, \xi, d_\mu), d)|) \right. \\ &\quad \left. - \int_0^t \gamma(|d(s)| \varphi(|x_\varphi(s, x_\varphi(h, \xi, d_\mu), d)|)) ds \right\} \\ &= \sup_{t \geq 0, d \in \mathcal{M}} \left\{ \alpha(|x_\varphi(t+h, \xi, \tilde{d})|) \right. \\ &\quad \left. - \int_0^t \gamma(|d(s)| \varphi(|x_\varphi(s+h, \xi, \tilde{d})|)) ds \right\} \\ &= \sup_{\tau \geq h, d \in \mathcal{M}} \left\{ \alpha(|x_\varphi(\tau, \xi, \tilde{d})|) \right. \\ &\quad \left. - \int_h^\tau \gamma(|d(s_1-h)| \varphi(|x_\varphi(s_1, \xi, \tilde{d})|)) ds_1 \right\} \\ &\leq \sup_{\tau \geq 0, d \in \mathcal{M}} \left\{ \alpha(|x_\varphi(\tau, \xi, \tilde{d})|) \right. \\ &\quad \left. - \int_0^\tau \gamma(|\tilde{d}(s_1)| \varphi(|x_\varphi(s_1, \xi, \tilde{d})|)) ds_1 \right\} \\ &\quad + \int_0^h \gamma(|\mu| \varphi(|x_\varphi(s_1, \xi, d_\mu)|)) ds_1 \\ &\leq g(\xi) + \int_0^h \gamma(|\mu| \varphi(|x_\varphi(s_1, \xi, d_\mu)|)) ds_1, \end{aligned}$$

where \tilde{d} is the concatenation of d_μ and d : $\tilde{d}(t) = \mu$ if $0 \leq t \leq h$, and $\tilde{d}(t) = d(t-h)$ if $t > h$. Let $f_\mu(\xi) = f(\xi, \mu\varphi(|\xi|))$. Since g is locally Lipschitz on $\mathbb{R}^n \setminus \{0\}$, it is differentiable almost everywhere on $\mathbb{R}^n \setminus \{0\}$, and hence, for any $|\mu| \leq 1$,

$$\begin{aligned} L_{f_\mu} g(\xi) &= \lim_{h \rightarrow 0^+} \frac{g(x_\varphi(h, \xi, d_\mu)) - g(\xi)}{h} \\ &\leq \lim_{h \rightarrow 0^+} \frac{1}{h} \int_0^h \gamma(|\mu| \varphi(|x_\varphi(s_1, \xi, d_\mu)|)) ds_1, \quad \text{a.e.} \end{aligned}$$

It then follows that

$$L_{f_\mu} g(\xi) \leq \gamma(|\mu| \varphi(|\xi|))$$

almost everywhere.

Observe that, since an iISS system is necessarily 0-GAS, it follows from Proposition II.5 that there exists a smooth semi-proper function V_0 satisfying (12) with some continuous positive definite function ρ and some \mathcal{K} -function σ . Let $V_1 : \mathbb{R}^n \rightarrow \mathbb{R}$ be defined by $V_1(\xi) = V_0(\xi) + g(\xi)$. Then V_1 is locally Lipschitz on $\mathbb{R}^n \setminus \{0\}$ and continuous everywhere. Furthermore,

$$\alpha(|\xi|) \leq V_1(\xi) \leq \bar{\alpha}_2(|\xi|)$$

for some $\bar{\alpha}_2 \in \mathcal{K}_\infty$, and it holds that, for all $|\mu| \leq 1$,

$$DV_1(\xi) f(\xi, \mu\varphi(|\xi|)) \leq -\rho(|\xi|) + \gamma_1(|\mu| \varphi(|\xi|))$$

almost everywhere, where $\gamma_1(s) = \sigma(s) + \gamma(s)$. By Theorem B.1 in [16], one sees that there exists a continuous function V_2 , smooth on $\mathbb{R}^n \setminus \{0\}$, such that

$$\frac{\alpha(|\xi|)}{2} \leq V_2(\xi) \leq 2\bar{\alpha}_2(|\xi|), \quad \forall \xi \in \mathbb{R}^n,$$

and

$$DV_2(\xi) f(\xi, \mu\varphi(|\xi|)) \leq -\frac{\rho(|\xi|)}{2} + \gamma_1(|\mu| \varphi(|\xi|))$$

for all $\xi \neq 0$, all $|\mu| \leq 1$. By Proposition 4.2 in [16], one sees that there exists some smooth \mathcal{K}_∞ -function p such that $p'(s) > 0$ for all $s > 0$ and $p \circ V_2$ is smooth everywhere. Without loss of generality, one may assume that $p'(s) \leq 1$ for all $s > 0$. Otherwise, one may replace p by any smooth \mathcal{K}_∞ -function \tilde{p} with the property that $\tilde{p}'(s) = p'(s)$ in a neighborhood of 0 where $p'(s) \leq 1$ and $\tilde{p}'(s) \leq 1$ everywhere else. Finally, we let $V = p \circ V_2$. Then V satisfies (8) for some $\alpha_1, \alpha_2 \in \mathcal{K}_\infty$, and

$$\begin{aligned} &DV(\xi) f(\xi, \mu\varphi(|\xi|)) \\ &\leq -p'(V_2(\xi))\rho(|\xi|)/2 + p'(V_2(\xi))\gamma_1(|\mu| \varphi(|\xi|)) \\ &\leq -\alpha_3(|\xi|) + \gamma_1(|\mu| \varphi(|\xi|)) \end{aligned}$$

for all $\xi \in \mathbb{R}^n$, all $|\mu| \leq 1$, where α_3 is any continuous positive definite function with the property that $\alpha_3(|\xi|) \leq p'(V_2(\xi))\rho(|\xi|)/2$ (e.g., $\alpha_3(s) = p'(\alpha(s)/2)\rho(s)/2$). It then follows that

$$DV(\xi) f(\xi, \nu) \leq -\alpha_3(|\xi|) + \gamma_1(|\nu|)$$

for all $\xi \in \mathbb{R}^n$, all $|\nu| \leq \varphi(|\xi|)$. To show that V satisfies an estimate of type (9), we let $\chi = \varphi^{-1}$, and let

$$\hat{\kappa}(r) := \max_{|\xi| \leq \chi(|\nu|), |\nu| \leq r} \{DV(\xi) f(\xi, \nu) + \alpha_3(|\nu|)\},$$

and

$$\kappa(r) = \max\{\hat{\kappa}(r), \gamma_1(r)\}.$$

Then $\kappa \in \mathcal{K}$, and for all $\xi \in \mathbb{R}^n$ and all $\nu \in \mathbb{R}^m$,

$$DV(\xi) f(\xi, \nu) \leq -\alpha_3(|\xi|) + \kappa(|\nu|)$$

(consider the two cases: $|\xi| \leq \chi(|\nu|)$ and $|\xi| \geq \chi(|\nu|)$). This shows that V is indeed an iISS-Lyapunov function for system (5).

Finally we show how to obtain the result without assuming that γ is smooth. First of all, one may always assume that $\gamma(r) \geq r$ for all r . (Otherwise, replace $\gamma(r)$ by $\gamma(r) + r$.) Pick any \mathcal{K}_∞ -function θ such that $\theta(\sqrt{s})$ is smooth and $\theta(s) \leq \gamma^{-1}(s)$ for all $s \geq 0$. Consider the system

$$\dot{x}(t) = \hat{f}(x(t), u(t)) := f(x(t), \sigma(u(t))\theta(|u(t)|)), \quad (28)$$

where $\sigma : \mathbb{R}^m \rightarrow \mathbb{R}$ is defined by $\sigma(\mu) = \frac{\mu}{|\mu|}$ if $|\mu| \neq 0$, and $\sigma(\mu) = 0$ if $|\mu| = 0$. Since θ is continuously differentiable and $\theta(0) = \theta'(0) = 0$, it follows that $\sigma(\nu)\theta(|\nu|)$ is C^1 , and hence, \hat{f} is also a locally Lipschitz map. We let $x^\theta(t, \xi, u)$ denote the trajectory of this system corresponding to the initial state ξ and the input u . It then holds that

$$\begin{aligned} \alpha(|x^\theta(t, \xi, u)|) &\leq \beta(|\xi|, t) + \int_0^t \gamma(\theta(|u(s)|)) ds \\ &\leq \beta(|\xi|, t) + \int_0^t |u(s)| ds \end{aligned}$$

for all ξ and all u . Hence, the system $\dot{x} = \hat{f}(x, u)$ is iISS with a smooth “gain”-function (which is the identity function). Applying the above proved result to this system, one sees that there exists a smooth iISS-Lyapunov function V satisfying

$$DV(\xi)f(\xi, \sigma(\mu)\theta(|\mu|)) \leq -\alpha_3(|\xi|) + \kappa_2(|\mu|)$$

for some continuous positive definite function α_3 and some \mathcal{K} -function κ_2 . Observe that

$$\nu = \sigma(\nu)\theta(\theta^{-1}(|\nu|))$$

for all $\nu \in \mathbb{R}^m$. Hence,

$$DV(\xi)f(\xi, \nu) \leq -\alpha_3(|\xi|) + \kappa_2(\theta^{-1}(|\nu|))$$

for all $\xi \in \mathbb{R}^n$, all $\nu \in \mathbb{R}^m$.

Proof of Proposition II.5

To prove Proposition II.5, we need the following result:

Lemma IV.10: System (5) is 0-GAS if and only if there exist a smooth function $V : \mathbb{R}^n \rightarrow \mathbb{R}$, \mathcal{K}_∞ functions $\alpha_1, \alpha_2, \alpha_3$, and \mathcal{K} -functions λ and δ , such that, for all $\xi \in \mathbb{R}^n$ and $\mu \in \mathbb{R}^m$,

$$\alpha_1(|\xi|) \leq V(\xi) \leq \alpha_2(|\xi|), \quad (29)$$

and

$$DV(\xi)f(\xi, \mu) \leq -\alpha_3(|\xi|) + \lambda(|\xi|)\delta(|\mu|). \quad (30)$$

Proof: Again, one direction of the implication is easy to prove by the Lyapunov direct method applied to system (5) for $u = 0$. The reverse is more interesting. Assume (5) is 0-GAS. Then we have $f(0, 0) = 0$, and by a converse Lyapunov argument (see e.g. [16]), there exist a smooth $V : \mathbb{R}^n \rightarrow \mathbb{R}$ and functions $\alpha_1, \alpha_2, \alpha_3$ in \mathcal{K}_∞ such that

$$\alpha_1(|\xi|) \leq V(\xi) \leq \alpha_2(|\xi|) \quad (31)$$

for all $\xi \in \mathbb{R}^n$, and

$$DV(\xi)f(\xi, 0) \leq -\alpha_3(|\xi|). \quad (32)$$

Consider now the following function:

$$\tilde{\gamma}(r, s) := \max_{|\xi| \leq r, |\mu| \leq s} |f(\xi, \mu) - f(\xi, 0) - f(0, \mu)|. \quad (33)$$

Notice that $\tilde{\gamma}(r, s)$ is continuous, nondecreasing with respect to each argument, and vanishes for $r = 0$ or $s = 0$ (since $f(0, 0) = 0$). Hence, it can be majorized by a function $\gamma(r, s)$ separately of class \mathcal{K} (e.g., we can take $\tilde{\gamma}(r, s) + r + s$). We pick σ as in Corollary IV.5. Then, it follows from (32) and Corollary IV.5 that:

$$\begin{aligned} DV(\xi)f(\xi, \mu) &= DV(\xi)[f(\xi, \mu) - f(\xi, 0)] + DV(\xi)f(\xi, 0) \\ &\leq DV(\xi)[f(\xi, \mu) - f(\xi, 0) - f(0, \mu)] \\ &\quad + DV(\xi)f(0, \mu) - \alpha_3(|\xi|) \\ &\leq |DV(\xi)|\gamma(|\xi|, |\mu|) \\ &\quad + |DV(\xi)||f(0, \mu)| - \alpha_3(|\xi|) \\ &\leq |DV(\xi)|\sigma(|\xi|)\sigma(|\mu|) \\ &\quad + |DV(\xi)||f(0, \mu)| - \alpha_3(|\xi|). \end{aligned} \quad (34)$$

It follows from (31) that $\xi = 0$ is a global minimum for $V(\xi)$ and hence $DV(0) = 0$; so, since V is smooth, continuity of DV gives that

$$\kappa(r) = r + \max_{|\xi| \leq r} |DV(\xi)| \quad (35)$$

is a class \mathcal{K} function. By local Lipschitz continuity of $f(\cdot, \cdot)$, also $|f(0, \mu)| \leq \chi(|\mu|)$ for some $\chi \in \mathcal{K}$. Thus, recalling equations (34) and (35) we have,

$$\begin{aligned} DV(\xi)f(\xi, \mu) &\leq -\alpha_3(|\xi|) + \kappa(|\xi|)\sigma(|\xi|)\sigma(|\mu|) + \kappa(|\xi|)\chi(|\mu|) \\ &\leq -\alpha_3(|\xi|) + \lambda(|\xi|)\delta(|\mu|), \end{aligned}$$

with $\lambda(r) = \kappa(r)\sigma(r) + \kappa(r)$ and $\delta(r) = \sigma(r) + \chi(r)$. \blacksquare

Remark IV.11: The same result can also be obtained along different lines, exploiting a result appeared in [22]. It is shown there that the 0-GAS property for system (5) implies the existence of an everywhere nonzero smooth function $G(x)$ such that $\dot{x} = f(x, G(x)v)$ is ISS with respect to v . Then, the result follows from the Lyapunov characterization of input-to-state stability. \square

We now can complete the proof of Proposition II.5. Define $\pi(\cdot)$ of class \mathcal{K} as follows:

$$\pi(r) = \int_0^r \frac{ds}{1 + \chi(s)}, \quad (36)$$

with χ a suitable class \mathcal{K} function to be defined later. It follows from 0-GAS that there exists a smooth $V(\xi)$ as in Lemma IV.10. Composing π with V and taking derivatives yields:

$$\begin{aligned} D[(\pi \circ V)(\xi)]f(\xi, \mu) &= \frac{DV(\xi)f(\xi, \mu)}{1 + \chi(V(\xi))} \\ &\leq \frac{-\alpha_3(|\xi|)}{1 + \chi(V(\xi))} + \frac{\lambda(|\xi|)\delta(|\mu|)}{1 + \chi(V(\xi))}. \end{aligned}$$

Then, letting $\chi(r) = \lambda \circ \alpha_1^{-1}$, $W = \pi \circ V$, and recalling (29) we obtain:

$$DW(\xi) f(\xi, \mu) \leq -\rho(|\xi|) + \delta(|\mu|), \quad (37)$$

where ρ is the continuous positive definite function defined as

$$\frac{\alpha_3(r)}{1 + \lambda(\alpha_1^{-1}(\alpha_2(r)))}.$$

V. A COUNTER-EXAMPLE

As already remarked in section 2, iISS implies 0-GAS. The converse is easily seen to be false, taking any 0-GAS system that exhibits a finite escape time for some constant input signal $u \neq 0$. In fact, it follows by definition (6) that iISS implies *forward completeness* of the control system (5), viz., for any control u and any $\xi \in \mathbb{R}^n$, the unique maximal solution of the initial value problem $\dot{x} = f(x, u)$, $x(0) = \xi$, is defined over the interval $[0, +\infty)$. It is reasonable to conjecture that iISS might be equivalent to simply forward completeness plus 0-GAS. This would make the iISS concept less interesting. In this section, we provide a counter-example to this conjecture, exhibiting a system that is forward complete and 0-GAS, but is not iISS. In other words, this example shows that, even when restricting attention to forward complete systems, iISS is a strictly stronger property than 0-GAS.

We begin the construction with a differential equation

$$\dot{x} = f(x)$$

which evolves in \mathbb{R}^2 and satisfies:

1. it is GAS;
2. $|f(x)| \leq 1$ for all $x \in \mathbb{R}^2$; and
3. there is a sequence of states

$$x^0, z^0, x^1, z^1, x^2, z^2, \dots$$

so that $x(T_k, x^k) = z^k$ for each k , for some sequence of positive numbers $\{T_k\}$, (where $x(\cdot, p)$ denotes the trajectory of the system with initial value p), and

$$x^k = \begin{pmatrix} 4k \\ * \end{pmatrix}, \quad z^k = \begin{pmatrix} 4k+3 \\ * \end{pmatrix}$$

for each k , where “*” is arbitrary.

It is easy to construct such differential equations. For example, one may start with a linear system $\dot{x} = Ax$, having an A matrix which is Hurwitz with non-real eigenvalues, and constructed so that its orbits are clockwise-turning converging spirals. One then scales the equation so that sequences of points as claimed exist, and finally one divides Ax by $1 + |Ax|^2$ in order to guarantee that $|f(x)| \leq 1$ for all x .

Let us denote $\Delta_k := \max\{|x^{i+1} - z^i| : 0 \leq i \leq k\}$, $k = 0, 1, 2, \dots$, and pick any scalar function $\varphi : \mathbb{R} \rightarrow \mathbb{R}$ which satisfies the following properties:

1. $\varphi(r) = 0$ when $r \in [4k+1, 4k+2]$, for all $k = 0, 1, 2, \dots$,
2. $\varphi(r) = 2^k \Delta_k + 1$ when $r \in [4k+3, 4(k+1)]$, for all $k = 0, 1, 2, \dots$,

3. $0 \leq \varphi(r) \leq 2^k \Delta_k + 1$ if $r \leq 4(k+1)$, for all $k = 0, 1, 2, \dots$,
4. $\varphi(r) = 0$ if $r \leq 0$.

The hypotheses imply that $\varphi(r) \leq M(r)$ for all r , where M is some increasing function which is zero for negative r (all we need, for $r > 0$, is $M(r) \geq 2^k \Delta_k + 1$, where k is the least positive integer so that $r < 4(k+1)$). See Fig. 4 for an illustration of the orbits of f and φ . Now we let $G(x) =$

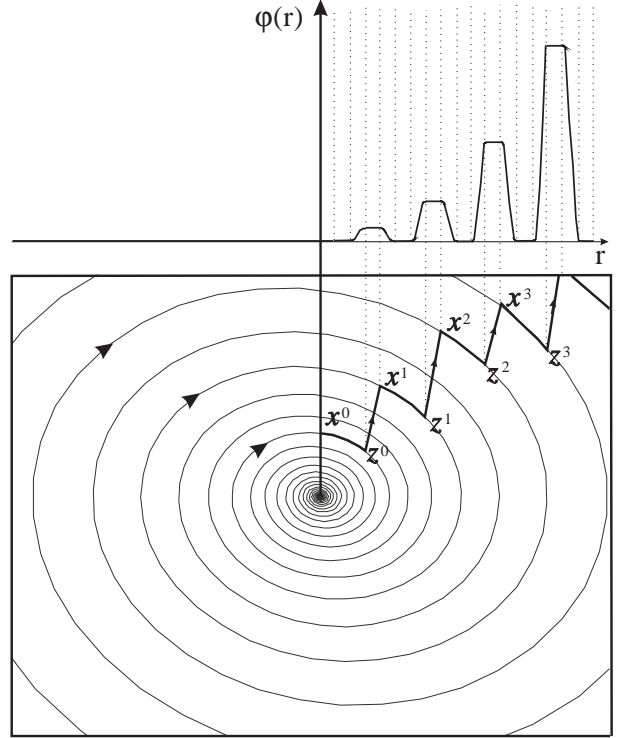

Fig. 4. Flow f and function φ for example of forward complete, 0-GAS but not iISS system

$\varphi(x_1)I$ (that is, G depends only on the first coordinate) and consider the two-input system $\dot{x} = f(x) + G(x)u$. We will show that this system is complete but is not iISS; it is 0-GAS by construction.

Claim: This system $\dot{x} = f(x) + G(x)u$ is complete.

Proof: Let $x(\cdot)$ be a maximal trajectory corresponding to a given control u and initial condition $x(0)$, and suppose that x is defined on an interval $[0, T)$, with $T < \infty$. Let K be an upper bound on the supremum norm of u (controls are locally essentially bounded, by definition). We will show that the trajectory is bounded, thus contradicting $T < \infty$. We look at the first coordinates x_1 of the states along this trajectory. There are two cases to consider:

- (i) $\{x_1(t), t \in [0, T)\}$ is bounded above.

Suppose that $x_1(t) \leq L$ for all t . Then, since $|G(x)| = \varphi(x_1) \leq M(x_1)$ for all x , the velocities are bounded by $1 + M(L)K$ and so the trajectory stays in the ball about $x(0)$ of radius $(1 + M(L)K)T$.

- (ii) $\{x_1(t), t \in [0, T)\}$ is not bounded above.

There must be an infinite number of intervals of the form $[4k+1, 4k+2]$ which are transversed by $x_1(t)$. That is, there are a countable set of disjoint closed intervals J_1, J_2, \dots included in $[0, T)$, each $J_i = [s_i, t_i]$, so that $x_1(s_i) = 4k_i + 1$

and $x_1(t_i) = 4k_i + 2$, for some k_i 's. We claim that every J_i has length at least one, which then contradicts $T < \infty$. Indeed, take any interval J_i and suppose that $t_i - s_i < 1$. Observe that, on J_i , $\varphi \equiv 0$, so the system equations are $\dot{x} = f(x)$. By the Mean Value Theorem,

$$1 \leq |x(t_i) - x(s_i)| \leq |f(x(t))| (t_i - s_i) < 1,$$

a contradiction. This completes the proof of completeness.

Claim: This system is not iISS.

Proof: We will show that there is an initial state ξ and a control u so that $|x(t, \xi, u)| \rightarrow \infty$ as $t \rightarrow \infty$, where u has the following property: there is some increasing sequence $t_k \rightarrow +\infty$ so that

$$|u(t)| \leq 1 \text{ if } t \in [t_k, t_k + 2^{-k}]$$

and $u(t) = 0$ otherwise; moreover, the sequence is also assumed to satisfy $t_{k+1} - t_k > 2^{-k}$.

The existence of such ξ, u means that the system cannot be iISS. To see this, suppose that the system would be iISS. Then, for some $\alpha, \gamma \in \mathcal{K}_\infty$, it holds that

$$\begin{aligned} \limsup_{t \rightarrow \infty} \alpha(|x(t, \xi, u)|) &\leq \int_0^\infty \gamma(|u(s)|) ds \\ &\leq \sum_{k=0}^\infty \int_{[t_k, t_k + 2^{-k}]} \gamma(1) ds = 2\gamma(1) < \infty, \end{aligned}$$

but this contradicts the fact that $|x(t, \xi, u)| \rightarrow \infty$ as $t \rightarrow \infty$.

We start with $\xi = x^1$, and let $u \equiv 0$ on $[0, t_1]$, where $t_1 := T_1$. So, $x(t_1, \xi, u) = z^1$, and $t_1 \geq 1$ because of the assumption that $|f(x)| \leq 1$. Next we continue building the control u and the trajectory $x(\cdot) = x(\cdot, \xi, u)$, inductively on the intervals

$$[t_k, t_{k+1}].$$

We do the construction in such a fashion that

$$x(t_k) = z_k$$

and

$$x(t_k + 2^{-k}) = x^{k+1}$$

for $k = 1, 2, \dots$. The idea is to switch between an uncontrolled motion on every interval of the form $[t_k + 2^{-k}, t_{k+1}]$ and appropriate control motions on the small intervals. To clarify the construction, we first do separately the case $k = 1$.

The control on the interval $[t_1, t_1 + 1/2]$ is defined as follows. We wish to force

$$x(t) = z^1 + 2(t - t_1)(x^2 - z^1), \quad t \in [t_1, t_1 + 1/2]$$

so that we go from $x(t_1) = z^1$ to $x(t_1 + 1/2) = x^2$ along a straight line. The equation $\dot{x} = f + Gu$ along this line is:

$$2(x^2 - z^1) - f(x(t)) = G(x(t))u(t) = (2\Delta_1 + 1)u(t)$$

so we may let

$$u(t) := \frac{2(x^2 - z^1) - f(z^1 + 2(t - t_1)(x^2 - z^1))}{2\Delta_1 + 1}.$$

Since $|x^2 - z^1| \leq \Delta_1$ (by definition of the Δ_k 's) and $|f(x(t))| \leq 1$ for all t , we conclude that $|u(t)| \leq 1$ on $[t_1, t_1 + 1/2]$, as was desired. Finally, we let $u(t) = 0$ for $t \in [t_1 + 1/2, t_2]$, where $t_2 := T_2 + (t_1 + 1/2)$, which makes $x(t_2) = z^2$.

Now we do the case of arbitrary k . We pick the curve:

$$x(t) = z^k + 2^k(t - t_k)(x^{k+1} - z^k), \quad t \in [t_k, t_k + 2^{-k}]$$

so that we go from $x(t_k) = z^k$ to $x(t_k + 2^{-k}) = x^{k+1}$ along a line, and the equation along this line becomes:

$$\begin{aligned} 2^k(x^{k+1} - z^k) - f(x(t)) \\ = G(x(t))u(t) = (2^k\Delta_k + 1)u(t) \end{aligned}$$

so we may let $u(t)$ be as follows

$$\frac{2^k(x^{k+1} - z^k) - f(z^k + 2^k(t - t_k)(x^{k+1} - z^k))}{(2^k\Delta_k + 1)}.$$

Since $|x^{k+1} - z^k| \leq \Delta_k$ and $|f(x(t))| \leq 1$ for all t , we have $|u(t)| \leq 1$ for all t in this interval of length 2^{-k} . Finally, we let

$$u(t) = 0 \text{ for } t \in [t_k + 2^{-k}, t_{k+1}],$$

where $t_{k+1} := T_{k+1} + (t_k + \frac{1}{2^k})$, so that we have $x(t_{k+1}) = z^{k+1}$, as needed for the induction step. ■

VI. COMMENTS ON RELATED NOTIONS

The notion of iISS differs from ISS in its use of “ $\int \gamma(|u|)$ ” instead of “ $\sup \gamma(|u|)$.” The same substitution may be used to define analogues of input/output stability and of detectability notions. We briefly discuss some of these now. Reasons of space preclude a detailed discussion, but proofs of the various claims are not difficult to obtain by following steps like those used in the rest of the paper. In this section, we deal with systems with outputs

$$\dot{x} = f(x, u), \quad y = h(x), \quad (38)$$

where, as earlier, the output map $h : \mathbb{R}^n \rightarrow \mathbb{R}^p$ is assumed to be continuous and $h(0) = 0$. For each $\xi \in \mathbb{R}^n$ and each input u , we let $y(t, \xi, u)$ be the output function of the system, i.e., $y(t, \xi, u) = h(x(t, \xi, u))$ (defined on some maximal interval $[0, T_{\xi, u})$).

Consider the following type of estimation:

$$\begin{aligned} \alpha(|x(t, \xi, u)|) &\leq \beta(|\xi|, t) \\ &+ \int_0^t \gamma_1(|y(s, \xi, u)|) ds + \int_0^t \gamma_2(|u(s)|) ds \end{aligned} \quad (39)$$

for all $t \in [0, T_{\xi, u})$, where $\beta \in \mathcal{KL}$, $\alpha \in \mathcal{K}_\infty$, and $\gamma_1, \gamma_2 \in \mathcal{K}$. If (39) holds for every trajectory of (38), then we say that system (38) is *integral input-output-to-state stable* (iIOSS). This is a notion of detectability: inputs and outputs are “small” implies that states are also small; see [27] for the corresponding notion of (sup-norm) IOSS. We say that a smooth function V is an *iIOSS-Lyapunov function* for system (38) if there exist functions $\alpha_1, \alpha_2 \in \mathcal{K}_\infty$, $\sigma_1, \sigma_2 \in \mathcal{K}$, and a continuous positive definite function α_3 , such that

$$\alpha_1(|\xi|) \leq V(\xi) \leq \alpha_2(|\xi|) \quad (40)$$

for all $\xi \in \mathbb{R}^n$, and

$$DV(\xi)f(\xi, \mu) \leq -\alpha_3(|\xi|) + \sigma_1(|h(\xi)|) + \sigma_2(|\mu|) \quad (41)$$

for all $\xi \in \mathbb{R}^n$ and all $\mu \in \mathbb{R}^m$. A proof analogous to that of Theorem 1, by virtue of Corollary IV.3, shows the following: *If a system admits an IOS-Lyapunov function, then the system is IOS.*

The area of input-to-output (as opposed to input-to-state) stability deals with properties which may be described, informally, as “small inputs produce small outputs.” Such properties appear naturally in regulation problems. In particular, one may define a concept of IOS (input-to-output stability), see [23] and [28]. This is yet another obvious candidate for the replacement of sup norms by integrals. So let us call system (38) *integral input-to-output stable* (IOS) if there exist $\alpha \in \mathcal{K}_\infty$, $\beta \in \mathcal{KL}$, and $\gamma \in \mathcal{K}$ such that

$$\alpha(|y(t, \xi, u)|) \leq \beta(|\xi|, t) + \int_0^t \gamma(|u(s)|) ds \quad (42)$$

holds on the maximal interval $[0, T_{\xi, u})$ for every trajectory of the system. Correspondingly, we may define a Lyapunov concept as follows. A smooth function V is called an *IOS-Lyapunov function* for system (38) if there exist functions $\alpha_1, \alpha_2 \in \mathcal{K}_\infty$, $\sigma \in \mathcal{K}$, and a continuous positive definite function α_3 , such that

$$\alpha_1(|h(\xi)|) \leq V(\xi) \leq \alpha_2(|\xi|) \quad (43)$$

for all $\xi \in \mathbb{R}^n$, and

$$DV(\xi)f(\xi, \mu) \leq -\alpha_3(V(\xi)) + \sigma(|\mu|) \quad (44)$$

for all $\xi \in \mathbb{R}^n$ and all $\mu \in \mathbb{R}^m$. Again, by virtue of Corollary IV.3, one can prove: *If a system admits an IOS-Lyapunov function, then the system is IOS.*

Note that the difference between (8) and (43) is that the function V in (8) is proper (i.e., radially unbounded), while in (43) the function V only majorizes a \mathcal{K}_∞ -function of $|y|$. It is also interesting to consider the following type of condition on V :

$$\alpha_1(|h(\xi)|) \leq V(\xi) \leq \alpha_2(|h(\xi)|) \quad (45)$$

for some \mathcal{K}_∞ -function α_1, α_2 . It then follows, again appealing to Corollary IV.3, that if system (38) admits a V satisfying (45) and (44), then the following holds for all trajectories of the system:

$$\begin{aligned} \alpha(|y(t, \xi, u)|) \\ \leq \beta(|y_0|, t) + \int_0^t \gamma(|u(s)|) ds, \quad \forall t \in [0, T_{\xi, u}), \end{aligned}$$

for some $\alpha \in \mathcal{K}_\infty$, $\beta \in \mathcal{KL}$ and $\gamma \in \mathcal{K}$, where $y_0 = y(0, \xi, u)$.

VII. CONCLUSIONS

The iISS notion was introduced and motivated both as a natural mathematical concept, generalizing finite H^2 gain,

and through a tracking problem and other applications. We proved a necessary and sufficient Lyapunov-like characterization of the iISS property, as well as a characterization based on a LaSalle-type dissipation inequality and detectability notions. We also provided a counterexample showing that iISS is not just the conjunction of forward completeness and 0-GAS. We are confident that the results presented here, besides their intrinsic interest, will motivate much further research into the theory and applications of iISS.

APPENDIX

I. APPENDICES

A. Proof of Lemma IV.1

Assume without loss of generality that $\rho(r) \rightarrow 0$ as $r \rightarrow +\infty$ (otherwise one can always consider $\tilde{\rho}(r) = \min\{\rho(r), 1/(1+r)\}$). Then the function ρ admits a global maximum over the interval $[0, +\infty)$. Let $M = \max_{r \geq 0} \rho(r)$, and define $\hat{\rho}(r) = \rho(r)/M$. Pick now $r_M > 0$ such that $\hat{\rho}(r_M) = 1$. Then, we can define the following functions:

$$\hat{\rho}_1(r) = \begin{cases} \min_{r \leq s \leq r_M} \hat{\rho}(s) & \text{for } r \leq r_M \\ 1 & \text{for } r > r_M, \end{cases} \quad (46)$$

$$\hat{\rho}_2(r) = \begin{cases} 1 & \text{for } r < r_M \\ \min_{r_M \leq s \leq r} \hat{\rho}(s) & \text{for } r \geq r_M. \end{cases}$$

Notice that $\hat{\rho}_1, (\hat{\rho}_2)$ is a non-decreasing (non-increasing) function, and, by equation (46), considering separately the cases $r > r_M$ and $r \leq r_M$,

$$\hat{\rho}(r) \geq \hat{\rho}_1(r) \hat{\rho}_2(r). \quad (47)$$

Then, we can choose ρ_1 and ρ_2 according to:

$$\begin{aligned} \rho_1(r) &= M \hat{\rho}_1(r) r \\ \rho_2(r) &= \hat{\rho}_2(r) / (1+r). \end{aligned}$$

Notice that $\rho_1 \in \mathcal{K}_\infty$ and $\rho_2 \in \mathcal{L}$. Taking into account (47) we have:

$$\rho(r) = M \hat{\rho}(r) \geq M \hat{\rho}_1(r) \hat{\rho}_2(r) \geq \rho_1(r) \rho_2(r) \quad (48)$$

for all $r \geq 0$. ■

B. Proof of Proposition IV.4

Proposition IV.4 will follow from the following result.

Lemma A.1: Let c be as in the statement of Proposition IV.4. Then, there exists a function $g \in \mathcal{N}$ such that, for each $y \in \mathbb{R}$,

$$c(x, y) - g(x) \rightarrow -\infty \text{ as } |x| \rightarrow \infty. \quad (49)$$

Proof: We will assume without loss of generality that $c(0, 0) > 0$. (If $c(0, 0) < 0$, we simply pick any constant a so that $a < c(0, 0)$, apply the Lemma to $c' := c - a$ to obtain some function g' , and then let $g := g' + a$.) Let

$$\bar{x} := \sup_{x \in \mathbb{R}} \{x \mid c(x, 0) = 0\}.$$

(Note that, since $c(\cdot, 0)$ is continuous, unbounded below, and achieves the some positive value, there is indeed at least one x so that $c(x, 0) = 0$; and by continuity, $c(\bar{x}, 0) = 0$). Now introduce the following set:

$$\mathcal{G} := \{(x, y) \in \mathbb{R}^2 \mid y \geq 0, c(x, y) + y = 0\}.$$

Claim: \mathcal{G} is the graph of a continuous, nonincreasing, onto function

$$g_0 : (-\infty, \bar{x}] \rightarrow [0, \infty).$$

To establish this claim, we first prove that, if $x_2 \leq x_1$ and $(x_1, y_1) \in \mathcal{G}$, then there is a y_2 so that $(x_2, y_2) \in \mathcal{G}$, and any such y_2 must satisfy $y_1 \leq y_2$. Consider the function $C(y) := c(x_2, y) + y$. As

$$C(y_1) = c(x_2, y_1) + y_1 \leq c(x_1, y_1) + y_1 = 0$$

and $C(y) \rightarrow +\infty$ as $y \rightarrow +\infty$ (because $c(x_2, \cdot)$ is nondecreasing), we conclude, using continuity of C , that there is some y_2 so that $C(y_2) = 0$, as required. And, given any y_2 so that $(x_2, y_2) \in \mathcal{G}$, if it were the case that $y_1 > y_2$ then it would hold that

$$0 = c(x_1, y_1) + y_1 > c(x_2, y_2) + y_2 = 0,$$

a contradiction. Thus, as stated, $y_1 \leq y_2$.

In particular, it follows that if (x, y_1) and (x, y_2) are both in \mathcal{G} then necessarily $y_1 = y_2$ (apply with $x_1 = x_2 = x$), so \mathcal{G} is the graph of some function g_0 , and g_0 is nonincreasing.

Next, we note that the projection of \mathcal{G} on the x coordinate (that is, the domain of the function g_0) is $(-\infty, \bar{x}]$. Pick any $(x, y) \in \mathcal{G}$. Suppose that $x > \bar{x}$. Then, $c(\bar{x}, 0) \leq c(x, 0) \leq c(x, y) + y = 0 = c(\bar{x}, 0)$ (using that c is nondecreasing in each variable, and $y \geq 0$). Then, $c(x, 0) = 0$, so $x \leq \bar{x}$ by maximality of \bar{x} , a contradiction. Thus, $x \leq \bar{x}$. Conversely, given any $x \leq \bar{x}$, we may apply again the argument given earlier (now with $x_2 = x$ and $x_1 = \bar{x}$) to obtain that there is some y so that $(x, y) \in \mathcal{G}$.

The projection of \mathcal{G} on the y coordinate is $[0, \infty)$. Indeed, pick any $y \geq 0$; as $c(\bar{x}, y) + y \geq c(\bar{x}, 0) = 0$ and $c(\cdot, y)$ is continuous and unbounded below, there is some x so that $c(x, y) + y = 0$.

To complete the proof of the claim, we need to see that g_0 is continuous. But this is an immediate consequence of the fact that g_0 is monotonic and onto an interval.

Finally, we define

$$g(x) := \begin{cases} -\frac{1}{2}g_0(x) & \text{if } x \leq \bar{x} \\ c(x, x) - c(\bar{x}, \bar{x}) + x - \bar{x} & \text{if } x > \bar{x}. \end{cases}$$

By construction, $g \in \mathcal{N}$. We show the desired limit property. Pick any $y \in \mathbb{R}$.

For $x \geq \max\{\bar{x}, y\}$,

$$c(x, y) - g(x) = c(x, y) - c(x, x) - x + c \leq c - x$$

where $c := \bar{x} + c(\bar{x}, \bar{x})$, so $c(x, y) - g(x) \rightarrow -\infty$ as $x \rightarrow +\infty$.

On the other hand, for any $x \leq \bar{x}$ such that $g_0(x) > y$,

$$\begin{aligned} c(x, y) - g(x) &= c(x, y) + \frac{1}{2}g_0(x) \\ &\leq c(x, g_0(x)) + g_0(x) - \frac{1}{2}g_0(x) = -\frac{1}{2}g_0(x) \end{aligned}$$

and $-\frac{1}{2}g_0(x) \rightarrow -\infty$ as $x \rightarrow -\infty$. \blacksquare

We now complete the proof of Proposition IV.4. Let g be as in Lemma A.1, and define the following function $h : \mathbb{R} \rightarrow \mathbb{R}$:

$$h(y) := \sup_{x \in \mathbb{R}} [c(x, y) - g(x)].$$

(As $c(\cdot, y) - g$ is continuous, and is negative for large $|x|$, the supremum is indeed finite.)

Since h is the sup of a family $\{c(x, \cdot) - g(x), x \in \mathbb{R}\}$ of continuous functions, h is itself continuous, and since each member of this family is nondecreasing, h is also nondecreasing. We prove now that $h(y) \rightarrow -\infty$ when $y \rightarrow -\infty$, which will then allow us to conclude that $h \in \mathcal{N}$.

Pick any $K \in \mathbb{R}$. For this K , we pick a $\rho > 0$ so that $c(x, 0) - g(x) < K$ whenever $|x| > \rho$. Next we pick an $L \leq 0$ so that $c(\rho, L) < K + g(-\rho)$. (Such an L exists because $c(\rho, \cdot)$ is unbounded below.) We claim that

$$y < L \Rightarrow h(y) < K.$$

Take one such y , and any $x \in \mathbb{R}$; we need to see that $c(x, y) - g(x) < K$. Consider first the case $|x| \leq \rho$; then

$$c(x, y) - g(x) \leq c(\rho, L) - g(-\rho) < K.$$

If instead $|x| > \rho$, then also

$$c(x, y) - g(x) \leq c(x, 0) - g(x) < K$$

(using that $y < L \leq 0$).

So we have constructed g and h in \mathcal{N} such that

$$\begin{aligned} c(x + y) &\leq g(x) + h(y) \\ &\leq \max\{g(x), h(x)\} + \max\{g(y), h(y)\} \end{aligned} \tag{50}$$

for all x and y . Thus, $k := \max\{g, h\}$ is as wanted for Proposition IV.4. \blacksquare

C. Resonance example

We explain here how the bounded control and the trajectory leading to $r(t)$ in Figures 2 and 3 were generated. To obtain this trajectory, we did as follows. We started with the initial state $(0, 0.1, 0, 0.1)'$, and took the feedback control $u_1 = 3 \tanh(z_1)$ ($= 3 \tanh(\theta)$) and $u_2 = 0$. Since $|\tanh(x)| \leq 1$ for all $x \in \mathbb{R}$, the input signal, resulting from this destabilizing feedback, shown in Fig. 3, is bounded. Note that a sort of “non-linear resonant behavior” is obtained. (It is worth pointing out that a similar effect is met also for vanishing references, if the convergence of u_1 to 0 is sufficiently slow.) The simulation used the parameters values shown in the next table, and were obtained using the

ode23 MATLAB routine, with tolerance 0.001 and initial condition $[0, 0.1, 0, 0.1]'$.

Parameter	Value	Parameter	Value
m	1	ML^2	3
k_{p1}	2	k_{d1}	2
k_{p2}	1	k_{d2}	1

REFERENCES

- [1] Angeli, D., "Input-to-state stability of PD-controlled robotic systems," *Automatica*, **35** (1999): 1285-1290.
- [2] Battilotti, S., "Robust stabilization of nonlinear systems with pointwise norm bounded uncertainties: A control Lyapunov approach," *IEEE Trans. Autom. Control* **44**(1999): 3-17.
- [3] Christofides, P.D., and A.R. Teel, "Singular perturbations and input-to-state stability," *IEEE Trans. Automat. Control* **41**(1996): 1645-1650.
- [4] Grüne, L., E.D. Sontag, and F. Wirth, "Asymptotic stability equals exponential stability, and ISS equals finite energy gain—if you twist your eyes," *Systems and Control Letters*, to appear.
- [5] Hahn, W., *Stability of Motion*, Springer-Verlag, Berlin, 1967.
- [6] Hespanha, J.P. and A.S. Morse, "Certainty equivalence implies detectability," *Systems and Control Letters* **36**(1999): 1-13.
- [7] Hespanha, J.P. and A.S. Morse, "Supervisory control of integral-input-to-state stabilizing controllers," *Proc. of the 5th European Control Conference*, Karlsruhe, September 1999.
- [8] Hu, X.M., "On state observers for nonlinear systems," *Systems & Control Letters* **17** (1991), pp. 645–473.
- [9] Isidori, A., "Global almost disturbance decoupling with stability for non minimum-phase single-input single-output nonlinear systems," *Systems & Control Letters* **28** (1996), pp. 115–122.
- [10] Kokotovic, P. and M. Arcak, "Constructive nonlinear control: progress in the 90's," Invited Plenary Talk, IFAC Congress, in *Proc. 14th IFAC World Congress*, the Plenary and Index Volume, pp. 49–77, Beijing, 1999.
- [11] Jiang, Z.-P., A. Teel, and L. Praly, "Small-gain theorem for ISS systems and applications," *Mathematics of Control, Signals, and Systems*, **7** (1994), pp. 95–120.
- [12] Khalil, H.K., *Nonlinear Systems*, Prentice-Hall, Upper Saddle River, NJ, second ed., 1996.
- [13] Krstic, M. and H. Deng, *Stabilization of Uncertain Nonlinear Systems*, Springer-Verlag, London, 1998.
- [14] Krstić, M., I. Kanellakopoulos, and P. V. Kokotović, *Nonlinear and Adaptive Control Design*, John Wiley & Sons, New York, 1995.
- [15] Liberzon, D., "ISS and integral-ISS disturbance attenuation with bounded controls," *IEEE Conf. on Decision and Control*, 1999, to appear.
- [16] Lin, Y., E.D. Sontag and Y. Wang, "A smooth converse Lyapunov theorem for robust stability," *SIAM Journal on Control and Optimization* **34**(1996): 124-160
- [17] Lu, W.M., A class of globally stabilizing controllers for nonlinear systems, *Systems & Control Letters* **25** (1995), pp. 13–19.
- [18] Lu, W.M., "A state-space approach to parameterization of stabilizing controllers for nonlinear systems," *IEEE Transactions on Automatic Control* **40** (1995): 1576–1588.
- [19] Marino, R., and P. Tomei, "Nonlinear output feedback tracking with almost disturbance decoupling," *IEEE Trans. Automat. Control* **44**(1999): 18–28.
- [20] Praly, L., and Y. Wang, "Stabilization in spite of matched unmodelled dynamics and an equivalent definition of input-to-state stability," *Math. of Control, Signals, and Systems* **9** (1996): 1-33.
- [21] Sepulchre, R., M. Jankovic, and P.V. Kokotovic, "Integrator forwarding: a new recursive nonlinear robust design," *Automatica* **33**(1997): 979-984.
- [22] Sontag, E.D., "Further facts about input to state stabilization," *IEEE Trans. on Autom. Control* **35**(1990): 473-476.
- [23] Sontag, E.D., "Smooth stabilization implies coprime factorization", *IEEE Trans. Automat. Contr.* **34**(1989): 435-443.
- [24] Sontag, E.D., "Comments on integral variants of ISS," *Systems and Control Letters* **34**(1998): 93-100.
- [25] Sontag, E.D., and Y. Wang, "On characterizations of the input-to-state stability property," *Systems & Control Letters* **24** (1995): 351-359.
- [26] Sontag, E.D., and Y. Wang, "New characterizations of the input to state stability property," *IEEE Trans. on Autom. Control* **41** (1996): 1283-1294.
- [27] Sontag, E.D., and Y. Wang, "Output-to-state stability and detectability of nonlinear systems," *Systems and Control Letters* **29**(1997): 279-290.
- [28] Sontag, E.D., and Y. Wang, "A notion of input to output stability," *Proc. European Control Conf.*, Brussels, July 1997, Paper WE-E A2, CD-ROM file ECC958.pdf, 6 pages.
- [29] Tsinias, J., "Input to state stability properties of nonlinear systems and applications to bounded feedback stabilization using saturation," *ESAIM Control Optim. Calc. Var.* **2**(1997): 57-85.
- [30] van der Schaft, A., *L₂-gain and passivity techniques in nonlinear control* (Lecture Notes in Control and Information Sciences, 218), Springer-Verlag, London, 1996.