

Constant McMillan Degree and the Continuous Stabilization of Families of Transfer Matrices

Eduardo D. Sontag*

This note deals with stabilization of parametric families using transfer matrices which are themselves parameterized in the same manner, a problem which is of some interest in the context of indirect adaptive control. It is shown that constancy of the McMillan degree is a necessary condition for stabilizability with arbitrary convergence rates.

1 Introduction

In indirect parameter adaptive control, one updates controller coefficients as new estimates of the plant are obtained. It is often of interest in that context to know if it is possible to design controllers that depend explicitly on plant parameters. For instance, if this dependence is polynomial or rational, the update itself consists simply of an evaluation, with no further computation. In addition to computational considerations, it is also of interest to know if one can design at least continuously on the parameters.

From the work of Delchamps ([De1]), we know that indeed continuous, and even analytic, dependence of controllers on parameters is possible. In [Sol], combining ideas of Delchamps together with a result given in that reference, we showed that it is even possible to obtain rational or polynomial dependency. The basic assumption in this kind of result is always that the McMillan degree of the plant does not vary over the parameter space. As

*Research supported in part by US Air Force Grant AFOSR-88-0235

far as we know, the question of whether this hypothesis is really necessary was not studied before.

In this note we show that the constant degree condition is necessary if one wishes to obtain stabilization with arbitrary rates of convergence. We also make some preliminary remarks regarding just stabilization (without the arbitrary rate requirement).

2 Definitions and Statement of Main Result

Let Λ be any connected topological space. A *family of (p by m) transfer matrices over Λ* is a parameterized p by m matrix $\{\mathcal{W}^\lambda(s)\}$ all whose entries are rational functions of s whose coefficients depend continuously on $\lambda \in \Lambda$, so that for each λ every entry is strictly proper; more precisely, there is a representation

$$\{\mathcal{W}^\lambda(s)\} = \left\{ \left(\frac{a_\lambda^{ij}(s)}{b_\lambda^{ij}(s)} \right) \right\}$$

where for each i, j , $a_\lambda^{ij}(s)$ and $b_\lambda^{ij}(s)$ are polynomials in s whose coefficients are continuous functions of λ ,

$$\deg a_\lambda^{ij}(s) < \deg b_\lambda^{ij}(s) \quad \forall i, j$$

and the leading coefficient of $b_\lambda^{ij}(s)$ is independent of λ .

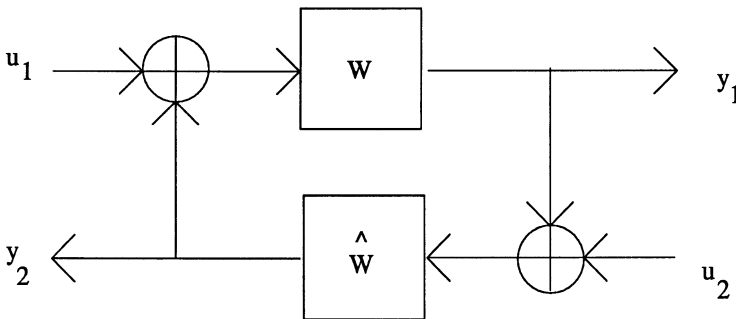

Figure 1. Interconnection of systems

Let $\{\mathcal{W}^\lambda(s)\}$ be a p by m family and let $\{\widehat{\mathcal{W}}^\lambda(s)\}$ be an m by p family; their *interconnection* is by definition the $p + m$ by $p + m$ family

$$\{\mathcal{W}^\lambda(s)\} \cdot \{\widehat{\mathcal{W}}^\lambda(s)\} := \begin{pmatrix} I & -\mathcal{W}^\lambda(s) \\ -\widehat{\mathcal{W}}^\lambda(s) & I \end{pmatrix}^{-1} \begin{pmatrix} \mathcal{W}^\lambda(s) & 0 \\ 0 & \widehat{\mathcal{W}}^\lambda(s) \end{pmatrix}$$

(this is well-defined since the first matrix is invertible as a rational matrix, by the strict properness condition). This definition corresponds to the i/o behavior of the additive feedback connection in Figure 1.

The above and all other definitions for families apply also to single transfer matrices, simply by considering a one-element Λ .

A *state space system* (of dimension n) is a triple of matrices $\Sigma = (A, B, C)$, where $A \in \mathbb{R}^{n \times n}, B \in \mathbb{R}^{n \times m}, C \in \mathbb{R}^{p \times n}$. We write

$$W[\Sigma] := C(sI - A)^{-1}B$$

for its transfer matrix, and say that Σ *realizes* $W[\Sigma]$. The *McMillan degree* $\deg W$ of a transfer matrix $W(s)$ is the smallest possible dimension of a state space realization of it.

For a family $\{\mathcal{W}^\lambda(s)\}$ the degree is a function $\delta(\lambda)$; since this degree can be computed from the nonvanishing of determinants in a Hankel matrix, δ is lower semicontinuous; that is, if $\delta(\lambda_0) = \delta_0$ then in a neighborhood of λ_0 also $\delta(\lambda) \geq \delta_0$.

For each family $\{\mathcal{W}^\lambda(s)\}$ let δ_0 be the maximum possible value of $\delta(\lambda)$, and let Λ_0 be the set where this value is achieved. The requirement that the degree of the family be constant is equivalent to asking that $\Lambda_0 = \Lambda$; since Λ is connected and Λ_0 is open (because of semicontinuity), this is equivalent to Λ_0 being closed.

2.1 Parametric Stabilization

For any fixed $\gamma < 0$, we shall say that a family of transfer matrices is γ -*stable* if it can be written in such a way that for each λ and each i, j , all zeroes of $b_\lambda^{ij}(s)$ satisfy $\text{Re } s \leq \gamma$.

A γ -*stabilizable* family is one for which there exists a $\{\widehat{\mathcal{W}}^\lambda\}$ so that the interconnection $\mathcal{W}^\lambda.\widehat{\mathcal{W}}^\lambda$ is γ -*stable*. A family is *stabilizable with arbitrary rates* if it is γ -*stabilizable* for all $\gamma < 0$.

The main result, to be proved in the next section, is as follows:

Theorem 1. *If a family is stabilizable with arbitrary rates then its McMillan degree is constant.*

Note that in the definition of stabilizable with arbitrary rates we allow the stabilizing family $\{\widehat{\mathcal{W}}^\lambda\}$ to be very different for each γ . It will follow from the Theorem, together with its already known converse ([De1]), that if a family is like this then it is also possible to build stabilizing families which depend continuously on γ in an appropriate sense. A family with constant degree is sometimes called “split”. See [Kh] for properties of such families, and relations to the existence of coprime factorizations.

3 Proof of the Theorem

Let $\Sigma = (A, B, C)$ be an n -dimensional state space system, and pick any $\gamma < 0$. We shall say that Σ is γ -*stabilizable and detectable* if it holds that

$$\text{rank}[sI - A, B] = n \text{ and } \text{rank}[sI - A', C'] = n$$

(prime indicates transpose) for each $s \in \mathbb{C}$ with $\text{Re } s > \gamma$. A *canonical* Σ is one which is γ -stabilizable and detectable for all $\gamma < 0$, or equivalently, controllable and observable.

The main lemma that we need is as follows.

Lemma 2. *Let $\{\mathcal{W}^\lambda(s)\}$ be a family of transfer matrices. For each $\bar{\lambda}$ in the closure of Λ_0 there exists a realization $\Sigma^{\bar{\lambda}}$ of dimension δ_0 with the following property: if the family is γ -stabilizable for some γ then $\Sigma^{\bar{\lambda}}$ is γ -stabilizable and detectable.*

The Theorem follows from here, since arbitrary stabilizability then implies that for each such $\bar{\lambda}$ the realization $\Sigma^{\bar{\lambda}}$ is canonical, and hence of minimal dimension by standard realization theory, which in turn implies that $\bar{\lambda} \in \Lambda_0$, which is therefore closed.

In order to prove the Lemma, we first establish the following result, which will be used twice and can be interpreted in terms of the quotient topology on classes of systems under the natural action of $GL(n)$, and is closely related to a result given in [De2].

Proposition 3. *Let $\{\mathcal{W}^\lambda(s)\}$ be a family of transfer matrices. Assume that $\text{deg } \mathcal{W}^{\lambda_j} \equiv q$ for some sequence $\{\lambda_j\}$ and some integer q , and that $\lambda_j \rightarrow \bar{\lambda}$ as $j \rightarrow \infty$. Then there exists some subsequence of the $\{\lambda_j\}$, which for notational simplicity we write again as $\{\lambda_j\}$, and for each element of this subsequence a system Σ^{λ_j} of dimension q , and there is a system $\Sigma^{\bar{\lambda}}$ of $\dim q$, so that the following properties hold:*

1. $\Sigma^{\lambda_j} \rightarrow \Sigma^{\bar{\lambda}}$
2. $W[\Sigma^{\lambda_j}] = \mathcal{W}^{\lambda_j}$ and $W[\Sigma^{\bar{\lambda}}] = \mathcal{W}^{\bar{\lambda}}$

PROOF. First notice that, using a large enough ρ , it is possible to construct a continuously parameterized family of ρ -dimensional realizations $\{\Sigma(\lambda)\}$ of $\{\mathcal{W}^\lambda(s)\}$ each of whose members is observable. This follows easily from the “observable form” realization (see e.g. [Ba], formula 4.112, but instead of the “ g ” in the construction given there, use the product of all denominators). By continuity, and since $\{\lambda_j\}$ is convergent, the realizations Σ^{λ_j} are all in a bounded subset of $\mathbb{R}^{\rho \times \rho} \times \mathbb{R}^{\rho \times m} \times \mathbb{R}^{p \times \rho}$.

Minimal realizations of the transfer matrices in the family $\{\mathcal{W}^\lambda(s)\}$ can be obtained by restricting to the reachable sets of these observable realizations. Using orthogonal bases for the restricted maps, we conclude that the sequence \mathcal{W}^{λ_j} can be realized by a bounded sequence of q -dimensional realizations. Thus there is a convergent subsequence of these realizations; call $\Sigma^{\bar{\lambda}}$ their limit. Continuity of transfer matrices on realizations gives the desired conclusions. Q.E.D.

Now we prove the Lemma. Let $\{\mathcal{W}^\lambda(s)\}$ and $\bar{\lambda}$ be as in the statement, and apply the Proposition, starting with any sequence of λ_j 's in Λ_0 converging to $\bar{\lambda}$, to obtain (taking first a subsequence if necessary) a sequence $\Sigma^{\lambda_j} \rightarrow \Sigma^{\bar{\lambda}}$ of realizations of dimension δ_0 of $\mathcal{W}^{\lambda_j}, \mathcal{W}^{\bar{\lambda}}$ respectively. This gives the realization $\mathcal{W}^{\bar{\lambda}}$ in the Lemma. Note that the systems Σ^{λ_j} are all minimal, since they have dimension equal to the maximal degree δ_0 , but that this is not necessary for the limit system $\Sigma^{\bar{\lambda}}$.

Assume that the family is γ -stabilizable for some γ . Let $\{\widehat{\mathcal{W}}^\lambda\}$ be as in the definition of γ -stabilizability. Since the McMillan degree of the family is bounded, may assume, taking if necessary a subsequence of $\{\lambda_j\}$, that $\text{deg } \widehat{\mathcal{W}}^{\lambda_j} \equiv q$ for some q . By the Proposition applied to these, and again taking a subsequence if necessary, we obtain realizations

$$\widehat{\Sigma}^{\lambda_j} \rightarrow \widehat{\Sigma}^{\bar{\lambda}}$$

for the corresponding sequences of stabilizing transfer matrices. Note that each $\widehat{\Sigma}^{\lambda_j}$ is a minimal realization of its transfer matrix, hence canonical.

Given any two systems $\Sigma = (A, B, C)$ and $\widehat{\Sigma} = (\widehat{A}, \widehat{B}, \widehat{C})$ we can define the interconnection $\Sigma.\widehat{\Sigma}$ again according to Figure 1; this is the system

$$\begin{pmatrix} A & B\widehat{C} \\ \widehat{B}C & \widehat{A} \end{pmatrix}, \begin{pmatrix} B & 0 \\ 0 & \widehat{B} \end{pmatrix}, \begin{pmatrix} C & 0 \\ 0 & \widehat{C} \end{pmatrix}$$

and it satisfies that

$$W[\Sigma.\widehat{\Sigma}] = W[\Sigma].W[\widehat{\Sigma}] .$$

In particular, we may consider the interconnections of the respective sequence elements, $\Sigma^{\lambda_j}.\widehat{\Sigma}^{\lambda_j}$. Note that

$$\Sigma^{\lambda_j}.\widehat{\Sigma}^{\lambda_j} \rightarrow \Sigma^{\bar{\lambda}}.\widehat{\Sigma}^{\bar{\lambda}} .$$

Further, the composite systems $\Sigma^{\lambda_j}.\widehat{\Sigma}^{\lambda_j}$ are all minimal realizations of the respective transfer matrices, since this is true for the component systems. Thus γ -stability of the interconnection of transfer matrices implies that the composite systems $\Sigma^{\lambda_j}.\widehat{\Sigma}^{\lambda_j}$ are internally γ -stable (eigenvalues with real part at most γ). By continuity of eigenvalues, the same is true for the

limit composite system $\Sigma^{\bar{\lambda}}.\widehat{\Sigma}^{\bar{\lambda}}$. This implies that $\widehat{\Sigma}^{\bar{\lambda}}$ is γ -stabilizable and detectable. The proof of the Lemma, and therefore of the Theorem, is then completed. Q.E.D.

4 Comments

It would be desirable to have a characterization of the property of γ -stabilizability (with a fixed γ). When the parameterization is for instance polynomial or even analytic, over the parameter spaces $\Lambda = \mathbb{R}$ or $\Lambda = \mathbb{R}^2$, there are parameterized realizations which are generically minimal (this follows from the results in [RS]). An argument as the one given above then proves that if the family is γ -stabilizable there must be a parameterized family of realizations consisting entirely of γ -stabilizable and detectable systems. This condition is "best possible" in the sense that it is also sufficient, and is related to stable coprime factorizations in the sense of [KS]. But the restriction to one- or two-parameter families is too strong, and much work needs to be done here.

REFERENCES

- [Ba] Barnett, S., *Polynomials and Linear Control Systems*, Dekker, NY, 1983.
- [De1] Delchamps, D.F., "Analytic stabilization and the algebraic Riccati equation," *Proc. IEEE Conf. Dec. and Control*, 1983, pp. 1396–1401.
- [De2] Delchamps, D.F., "Multivariable ARMAX identification: Some geometric questions," *Proc. 17th Annual Conference on Information Sciences and Systems*, Johns Hopkins University, Baltimore, 1983, pp. 287–292.
- [Kh] Khargonekar, P.P., "On matrix fraction representations for linear systems over commutative rings," *SIAM J. Control and Opt.* **20**(1982): 172–197.
- [KS] Khargonekar, P.P. and E.D.Sontag, "On the relation between stable matrix fraction decompositions and regulable realizations of systems over rings," *IEEE Trans. Autom. Control* **27**(1982):627–638.
- [RS] Rouchaleau, Y. and E.D.Sontag, "On the existence of minimal realizations of linear dynamical systems over Noetherian integral domains," *J. Comp. Syst. Sci.* **18**(1979):65–75.
- [So1] Sontag, E.D., "Parametric stabilization is easy," *Systems and Control Letters* **4**(1984): 181–188.

- [So2] Sontag, E.D., "An introduction to the stabilization problem for parametrized families of linear systems," in *Contemporary Mathematics, Vol.47, Linear Algebra and its Role in Systems Theory*, pp.369–400, AMS, Providence, RI, 1985.

Eduardo D. Sontag
SYCON - Rutgers Center for Systems and Control
Department of Mathematics, Rutgers University
New Brunswick, NJ 08903, USA
`sontag@fermat.rutgers.edu`
`sontag@pisces.bitnet`