

# Data Communications Via Cable Television Networks: Technical And Policy Considerations

Deborah Lynn Estrin

May 1982

© Massachusetts Institute of Technology 1982

Massachusetts Institute of Technology  
Laboratory for Computer Science  
Cambridge, Massachusetts 02139

# **Data Communications Via Cable Television Networks: Technical And Policy Considerations**

by

Deborah Lynn Estrin

Submitted to the  
Technology Policy Program,  
Department of Electrical Engineering and Computer Science,  
on May 7, 1982 in partial fulfillment of the requirements  
for the Degree of Master of Science

## **Abstract**

Cable television networks offer peak communication data rates that are orders of magnitude greater than the telephone local loop. Although one-way television signal distribution continues to be the primary application of cable television systems, the cable television network can be used for two-way data communications.

Data communication places severe engineering demands on the performance of a cable television network. Therefore, to ensure that data communications capabilities are not precluded by poor engineering, local cable authorities and the cable industry must identify and overcome the technical barriers to the application of cable television networks to data communications. We identify the following as the primary technical requirements that remain to be addressed by the cable industry:

- Methods for controlling the accumulation of insertion noise and ingress on upstream channels.
- Reliability and security mechanisms to provide adequate levels of system availability, overall quality of service, and privacy of communications.
- System engineering that supports data communications among many nodes, other than on a point-to-point basis.

If the cable industry applies the resources necessary to satisfy these requirements, cable television networks can gain a lucrative share of the growing residential and institutional, data communications and information services markets, in competition with telephone company and cellular microwave services.

In order to make this important, and unique, municipal resource widely available to a diversity of users and service providers, local cable authorities, in addition to the cable industry, should establish structural mechanisms to eliminate the cable operator's potential conflict of interest between its carriage and content functions, which might otherwise inhibit this diversity. The nature of appropriate regulatory mechanisms has been a source of conflict and confusion because of the unclear status of the cable operator as broadcaster or common carrier. Leased channel access requirements, which enforce limited separations on a channel by channel basis, can allow the operator to serve in both capacities, thereby both encouraging investment in facilities and limiting the opportunities for anti-competitive practices. The rate structures and levels adopted by the operator will determine the extent to which leased channel access successfully achieves this end.

More than in the past, cable authorities will find themselves monitoring and specifying details of the network infrastructures, both technical and operational, to ensure that suitable facilities are constructed and that a diversity of service sources are granted access to the medium. This thesis is intended as a resource for cable authorities, as well as cable operators, as they establish the role of cable television networks in the data communications market. In particular, Chapter 6 serves as a guide for city and state cable authorities to incorporate the technical detail and regulatory structures necessary for data communication services into existing cable policy.

**Key Words:** cable television, telecommunications policy, computer networks

# Acknowledgments

I wish to thank my two thesis advisors, Prof. Jerry Saltzer and Dr. Marvin Sirbu.

Jerry Saltzer made it possible for me to pursue my technical interests, in addition to my non-technical ones, by welcoming me into the Computer Systems Research Group of the MIT Laboratory for Computer Science. His pointed and constructive criticisms, tempered with encouragement and enthusiasm, were priceless.

In addition to invaluable input to the development of this thesis, Marvin Sirbu gave an inordinate amount of his time to the review, and revision of the first draft. He served as a model for integrating technical and policy research.

I also wish to thank the EECS department for awarding me the Vinton Hayes Fellowship in support of my communications-research activities.

I am exceedingly grateful to Josef, my husband, who believed in me and in my efforts, and to my parents, Thelma and Gerald, who taught me the confidence needed to begin and complete this task.

# Table of Contents

<b>Chapter One: Introduction</b>	<b>11</b>
<b>1.1 Motivations and applications</b>	<b>12</b>
1.1.1 The markets	12
1.1.2 Proposed services	14
1.1.3 Existing applications	16
<b>1.2 A possible scenario</b>	<b>17</b>
<b>1.3 Overview of this report</b>	<b>18</b>
<b>Chapter Two: Cable Television as a Data Transmission Medium: Tutorial</b>	<b>20</b>
<b>2.1 Cable system components</b>	<b>21</b>
<b>2.1.1 Basic cable systems</b>	<b>21</b>
2.1.1.1 Headend equipment	22
2.1.1.2 Cable distribution plant -- cable, amplifiers, bridging amplifiers	23
2.1.1.3 Interface equipment	25
<b>2.1.2 Two-way cable system components</b>	<b>26</b>
2.1.2.1 Headend	26
2.1.2.2 Cable distribution plant	27
2.1.2.3 Interface units	28
<b>2.2 Access schemes and communication protocols for two-way data communications</b>	<b>29</b>
<b>2.2.1 Description of access schemes</b>	<b>29</b>
2.2.1.1 Polling	29
2.2.1.2 FDM	31
2.2.1.3 TDM	32
2.2.1.4 Contention schemes	32
<b>2.2.2 Performance characteristics of access schemes</b>	<b>34</b>
2.2.2.1 Throughput	34
2.2.2.2 Connectivity	35
2.2.2.3 System availability	36
2.2.2.4 Relative costs of access schemes	36
<b>2.3 Cable system limitations</b>	<b>37</b>
<b>2.3.1 Noise and corrective measures</b>	<b>38</b>
2.3.1.1 Insertion noise	38
2.3.1.2 Ingress	40
2.3.1.3 Corrective measures	41
<b>2.3.2 Reliability</b>	<b>43</b>
2.3.2.1 System reliability	43
2.3.2.2 Security and privacy	46
2.3.2.3 Institutional roadblocks to system reliability	47
<b>2.4 Summary</b>	<b>47</b>

<b>Chapter Three: Cable Television as a Data Transmission Medium: Analysis</b>	<b>48</b>
3.1 Impediments to Data Service Development	48
3.2 Service Structure Options	50
3.2.1 Conventional Residential Systems -- Headend to Subscriber	50
3.2.1.1 One-way Systems	50
3.2.1.2 Two-way Systems	51
3.2.2 Multiple Server Residential Networks	52
3.2.2.1 Institutional requirements	52
3.2.2.2 Technical requirements	53
3.2.3 Hybrid Residential Networks	56
3.2.4 Institutional Service -- Point-to-Point and Multipoint	57
3.3 Costs	57
3.3.1 Basic cable System Costs	58
3.3.2 Two-way Residential System Costs	60
3.3.2.1 Headend and Customer Premises Equipment	60
3.3.2.2 Cable Plant	62
3.3.2.3 Operation and maintenance	63
3.3.3 Two-way Institutional System Costs	63
3.4 Prices	66
3.5 Summary	69
<b>Chapter Four: Alternative media: telephone local loop and Digital Termination Services</b>	<b>70</b>
4.1 Telephone local loop	70
4.1.1 Circuit-Switched, Digital Capability	71
4.1.1.1 Costs	73
4.1.2 Data Above Voice (DAV) -- Local Area Data Transport (LADT) services	73
4.1.2.1 Costs	75
4.2 DTS	76
4.3 Comparison	76
<b>Chapter Five: Regulatory Issues</b>	<b>78</b>
5.1 Introduction	78
5.2 Regulatory Jurisdiction	80
5.2.1 Background	80
5.2.2 State and local regulation and federal preemption	81
5.2.3 The Local Franchising Process	83
5.3 Cable as Carrier and Broadcaster	84
5.3.1 Introduction	84
5.3.2 Content regulation	87
5.3.3 Economic regulation	89
5.3.4 Structural regulation	90
5.3.5 Leased channel access	94
5.3.6 Telephone company cross-ownership	97
5.4 Privacy -- Wiretapping, Intrusion, Misuse of Information	97

5.5 Summary	100
<b>Chapter Six: Guidelines for municipal policies</b>	<b>101</b>
6.1 Introduction	101
6.2 City goals and the role of data services	102
6.3 Entry points for municipal input	103
6.4 Community requirements	106
6.4.1 Technical requirements	107
6.4.1.1 Engineered for data	108
6.4.1.2 Addressability and access methods	109
6.4.1.3 Reliability and maintainability	110
6.4.1.4 Communication services	111
6.4.1.5 Interconnection	111
6.4.2 Operational requirements	112
6.4.2.1 Leased Access	112
6.4.2.2 System expansion	120
6.4.2.3 Separation of institutional and residential networks	121
6.4.2.4 Operator liability	121
6.4.2.5 Privacy	121
6.4.3 State policies	122
6.5 Summary	123
<b>Chapter Seven: Conclusions</b>	<b>124</b>
7.1 Network planning	124
7.2 Strategies for the cable industry	125
7.3 City policy	127
7.4 Suggestions for further research	128
<b>Appendix A: Provider Industry Structure: Snapshot of the Industry, January, 1982</b>	<b>129</b>
A.1 Customer Premises Equipment Companies	129
A.1.1 Converter Manufacturers	130
A.1.1.1 E-Com	130
A.1.1.2 Control-Com	130
A.1.1.3 Tocom	131
A.1.1.4 Pioneer	132
A.1.1.5 Jerrold	132
A.1.1.6 Oak Industries	132
A.1.1.7 Scientific Atlanta	132
A.1.2 Modem Manufacturers	133
A.1.2.1 Mitre	133
A.1.2.2 Local Data Distribution	133
A.1.3 Local Area Computer Network Vendors	134
A.1.3.1 Sytek and General Instruments	134
A.1.3.2 Amdax	138

A.1.3.3 Wang	138
A.1.3.4 Interactive Systems/3M	139
A.2 Services	139
A.2.1 Cable Operators	139
A.2.1.1 Warner-Amex	139
A.2.1.2 COX Cable	140
A.2.1.3 Times Inc. -- Manhattan Cable	142
A.2.1.4 Rogers Cablesystems	142
A.2.1.5 Sammons Communications	143
A.2.2 Transaction Service Providers	144
A.2.3 Information Service Providers	144
A.2.4 Communication Service Providers	145
<b>Appendix B: Glossary of mnemonics</b>	<b>146</b>



## Table of Figures

Figure 2-1: Cable Network Components	22
Figure 2-2: Tree Topology	25
Figure 2-3: Hub Topology	26
Figure 2-4: Sources of signal noise and interference	39
Figure 2-5: Digital regenerator used to reduce upstream noise	42
Figure 4-1: Circuit Switched Digital Capability	72
Figure 4-2: Local Area Data Transport	74
Figure 5-1: Warner Amex Code of Privacy	99
Figure 6-1: Cable television system franchising	104

## Table of Tables

<b>Table 1-1: Some proposed interactive services for cable television</b>	<b>15</b>
<b>Table 3-1: Distribution plant component prices</b>	<b>58</b>
<b>Table 3-2: Broadband local area network vendor prices</b>	<b>65</b>
<b>Table 3-3: Cost profiles of four systems</b>	<b>65</b>
<b>Table 3-4: Typical cost per subscriber</b>	<b>66</b>
<b>Table 3-5: MCTV monthly lease rates</b>	<b>67</b>

# Chapter One

## Introduction

Cable television networks<sup>1</sup> were designed to distribute television signals from a central location to residential homes throughout a local region. These systems were used originally to provide entertainment television to regions where over-the-air reception was not satisfactory. Increasingly, they are used to provide a greater diversity of programs than over-the-air spectrum limitations permit, and as a means of delivering premium television services<sup>2</sup>.

Although one-way television signal distribution continues to be the primary application of cable systems, the technology is also appropriate for two-way communications. This report focuses on developments in two-way communications over city cable systems, in particular, two-way *data communication services*.

Data communication places intense technical demands on the performance of a cable television network. Therefore, to ensure that data communications capabilities are not precluded by poor engineering, the city cable authority and the cable operator must identify and overcome the technical barriers to the application of cable television networks to data communications. More than in the past, the cable authority will find itself specifying details of the network infrastructures, both technical and operational, to ensure that suitable facilities are constructed and that a diversity of service sources are granted access to the medium.

---

<sup>1</sup> Also known as cable networks, or CATV (Community Antenna Television) systems. Throughout this report we will use the term "cable networks" interchangeably with "cable television networks" and "cable television systems".

<sup>2</sup> Also referred to as pay-television.

## **1.1 Motivations and applications**

This section sets the stage for our discussion of data communications via cable television networks. It is not a rigorous survey of the market research in this area, but provides a sampling of envisioned markets and applications. In so doing, we hope to communicate to the reader why data communications via cable television networks is of interest to cities, residents, commercial and government users, and the cable industry.

### **1.1.1 The markets**

There are two distinct markets for data communications: residential and institutional. There are also two categories of service: information and communication. Information services refer to those services whereby a second party provides the content which is accessed, requested, or responded to by the user. Communication services provide only the transmission and switching services, all content is provided by the users independently of the communication service provider; users being persons, organizations, computers, or other communicating devices.

The intracity market for business data communications already exists. Projections for its growth are based on the increasing use of computer equipment within the office which will in turn generate demand for increasing amounts of intracity communications. Currently, intracity communication needs must be satisfied by the telephone company (see Section 4). Intermittent demand for data communications is satisfied by dial-up facilities at speeds up to 4800 baud. Dedicated facilities are also available at speeds up to 56 Kbps. Point-to-point communications facilities are available at higher speeds, but switched services are not. In the future, considerable demand is projected for high speed switched networks which will accommodate intracity communications of both continuous and intermittent natures. An institutional market for information services exists and is growing. Services such as Lexus and Nexus<sup>3</sup> will be spurred by the growth of standardized videotex services for the business sector. These services will provide a common standard, or gateway, whereby users can access many information sources.

---

<sup>3</sup>Legal and medical data base services.

Unlike the institutional market, the residential market for information services does not exist. Projections for its growth are based primarily on projections of supply, rather than demand. Although videotex is touted primarily as a home information service, it will grow as a mass media service after it is established in the commercial sector [17]. Most existing residential data communications demand currently takes the form of professionals working at home using terminals and modems to talk to central computers and information services via phone lines. In addition, increasing numbers of personal computers, used for both personal and small business applications, are equipped with communications capabilities.

An informal random polling of 200 residents in a suburb of Boston which has a high concentration of professionals, resulted in approximately 3% who reported having terminals or personal computers in their homes<sup>4</sup>, another 13% reported having video games. In addition, the local cable operator estimates that approximately 25% of the homes passed will subscribe to pay-television. These numbers can be used as preliminary indicators of the size of the residential market. The number of residents with terminals indicates the minimum market size for data communications to the home. Similarly, the number of residents with video games indicates the number of residents who tend to invest in "high technology" entertainment devices for the home. Finally, the number of pay-television subscribers probably indicates a short to medium-term upper bound on the existing residential market for data services.

Projections for future applications of residential data communications range from transaction and information services to electronic mail and multi-person games. Services such as Teletext and Videotex have received considerable press coverage, but the degree and form of their success is still uncertain. To a large extent it hinges on the development and availability of information providers and inexpensive terminal equipment.

In 1981 there were 4,400 operating cable systems in the U.S. and an additional 2,000 that were approved but not yet built. These systems served approximately 10,400 communities and 17,200,000 subscribers, 22% of the T.V. households. The largest system had 188,880

---

<sup>4</sup>Survey conducted at M.I.T. Laboratory for Computer Science, January through April, 1982. Supervised by Prof. J. Saltzer, and D. Estrin.

subscribers<sup>5</sup>. Although most systems have 12 channels, systems constructed during the past 10 years have a minimum of 20 channels, and newly designed systems may have 50 or more channels [46]. Although there are wide variations, it is typical that half of the homes passed by the cable subscribe to it, and half of the subscribers purchase premium services such as pay-television<sup>6</sup>.

### **1.1.2 Proposed services**

In 1974 Baer et. al. [8] outlined a menu of possible applications for two-way cable systems, see Table 1-1.

Baran also studied the applications of broadband information networks and suggested the following categories of applications, many of which today appear farther off than they did eight years ago.

#### **1. Work at home**

- Person-to-person -- electronic mail.
- Secretarial assistance.
- Access to company files.

#### **2. Transaction services**

- Banking services.
- Shopping.
- Price lists and information.
- Consumer advisory service.

#### **3. General information access**

- Newspaper.

---

<sup>5</sup>Cox Cable San Diego system.

<sup>6</sup>Cable television statistics are reported weekly in each issue of *CableVision*, Titach Publishing Inc., Denver, Colorado.

- Fares and ticket reservations.

- Legal information.

- Library access.

#### 4. Entertainment

- Games.

- Multiperson games.

Subscriber	Institutional
Interactive instructional programs	Computer data exchange
Fire and burglar alarm monitoring	Teleconferencing
Television settings	Surveillance of public areas
Utility meter readings	Fire detection
Control of utility services	Police monitoring
Opinion polling	Traffic control
Market research surveys	Fingerprint and photograph identification
Interactive TV games	Civil defense communications
Quiz shows	Area transmitters/receivers for mobile radio
Pay TV	Classroom instructional TV
Special interest group conversations	Education extension classes
Electronic mail delivery	Televising municipal meetings
Electronic delivery of newspapers and periodicals	Direct response on local issues
Electronic cataloging and computer time sharing	Automatic vehicle identification
Catalog displays	Community relations programming
Stock market quotations	Information retrieval services
Transportation schedules	Education for the handicapped
Reservation services, ticket sales	Drug and alcohol abuse programs
Banking services	Health care, industry, and other public information programs
Inquiries from various directories	Business transactions
Local auction sales and swap shops	Crime control
Electronic voting	Signature and photo identification
Subscriber originated programming	Facsimile services
Interactive vocational counseling	Industrial security
Local ombudsman	Production monitoring
Employment, health care, housing, welfare, and other social service information	Industrial training
Library reference and other information retrieval services	Corporate news files
Dial-up video and audio libraries	Telediagnosis
Videophones	Medical record exchange

Table 1-1: Some proposed interactive services for cable television  
(Cable Television: Franchising Considerations)<sup>7</sup>

<sup>7</sup>Baer, W. [8]

Jones et. al. outlined urban public services which rely upon telecommunications and would be well suited to the use of broadband facilities.

1. Delivery of government services.
2. Citizen-government interaction.
3. City administration.
4. Status monitoring.

### 1.1.3 Existing applications

Since the time when these applications were proposed, seven years ago, few of the visions have been realized. Why does the application of cable networks to data communications seem any more viable today? The primary reason is that today many of the services already exist but use different, narrower bandwidth, higher cost, media such as telephone lines: connection of automated teller machines to bank branch offices; connection of terminals in urban and suburban schools to shared computer facilities, connection of airline reservation terminals to centralized data base facilities.

In fact, cable television technology is already in use as a data communications medium.

1. In the summer of 1981 New York City's Computer Service Center switched from phone lines to Manhattan Cable Television (MCTV) facilities for communications with the Manhattan municipal building. The switch reduced the city's data transmission cost by approximately one-third, from \$60,000 to \$20,000<sup>8</sup>.
2. Financial institutions in Manhattan have been using MCTV facilities since 1975 to connect Wall Street and Midtown offices.
3. Brown University in Rhode Island uses a broadband cable television network to interconnect terminals and computers throughout the campus<sup>9</sup>.
4. In addition, information services are being used, if primarily by businesses:
  - a. In the United Kingdom, there is a two-way information service, Prestel, which uses telephone lines to send information to and from users. Contrary

---

<sup>8</sup> Annual municipal data transmission costs for the City of New York are estimated to be \$10,000,000.

<sup>9</sup> Sytek Inc., LocalNet 20 system, see Appendix A.



to initial expectations of the British Telecom which developed and offered the service, it is used primarily by the business community.

b. In contrast to the videotex experience, the one-way teletext system now offered in the U.K. appears quite successful among residents<sup>10</sup>. This is attributable to lower teletext access costs as well as the rather undeveloped nature of the information provider services which therefore do not require the enhanced access features offered by videotex.

c. Lexus and Nexus legal and medical data base services.

d. Dow Jones stock market information services.

## 1.2 A possible scenario

In the short term cable operators will realize profits from institutional communication services, in competition with the local telephone company. In the longer term, as information services and inexpensive terminals become available, the residential market will also become important revenue source. As was the case with the telephone, residential subscriber services will be spurred by the desires of commercial users to reach consumers. Many of the first generation of information services may only allow users to communicate with the headend and any services that reside there. To further their growth, and increase subscriber penetration, cable operators will find it worthwhile to provide for multiple server networks (see Section 3.2.2). As a result of these developments, information services and communication services would be effectively merged. The cable operator would then offer communication services to both information and entertainments service providers and communication users, and would itself act as one of the service providers on the network.

---

<sup>10</sup> In a teletext system pages of information are "grabbed" from a constantly cycling data base of pages to simulate interactivity.

### **1.3 Overview of this report**

If the cable television networks fulfill their potential as important, and unique, municipal resources, they should be made widely available to a diversity of users and service providers. Therefore, local cable authorities, in addition to the cable industry, should establish structural mechanisms to eliminate the cable operator's conflict of interest between its carriage and content functions, which might otherwise inhibit this diversity. In addition, data communication places intense technical demands on the performance of a cable television network. Therefore, to ensure that data communications capabilities are not precluded by poor engineering, local cable authorities and the cable industry must identify and overcome the technical barriers to the application of cable television networks to data communications.

The application of cable television facilities to data communications raises many questions regarding the proper implementation and operation of the facilities. In this report we address these questions, some of which are listed below:

- Can data transmission be accommodated on existing cable networks?
- What engineering provisions must be made to handle two-way data transmission?
- How much will it cost to implement such provisions?
- What higher level communication protocols, such as addressing, should be implemented?
- Who should offer services?
- Who should decide what services are to be offered, and how should it be decided?
- Is the cable operator acting as a broadcaster or a common carrier?
- What regulatory or policy mechanisms are needed to achieve societal goals such as protection of first amendment right to hear and speak?
- How will access to the cable network be charged for?
- What role should the local cable authority play in specifying technical and operational details of the network?
- What must the cable industry do to prepare itself for offering these new services?

The first half of this report concentrates on technical issues that are not yet widely understood or appreciated in the cable television community. In particular, the cable industry must develop the expertise necessary for design and implementation of network facilities and services; the city cable authorities must understand the technology well enough to evaluate and monitor network planning and operation; and the users and information providers, need to plan their applications according to the existing, as well as potential, data communications capabilities of cable networks.

In Chapter 2 we present a tutorial on data communications over cable television networks, and in Chapter 3 we analyze the associated costs, impediments, and service structure options. These chapters should help the cable community better understand the technical issues and trade-offs encountered in the design of data communications facilities and services. We find that the communications protocols adopted largely determine the capabilities and performance of the system. In particular, the ability to communicate with many other points on the network, i.e., not only the headend, will be essential to future services. Performance is constrained by upstream noise and low reliability which may result from poor system engineering and the relative inexperience of the cable industry with data communications. In Chapter 4 we identify the unique properties of cable television technology (e.g., an economical, high-bandwidth medium that accommodates broadcast communications) by comparing it with other regional data distribution media (DTS and telephone).

The second half of this report addresses the national regulatory and local policy issues associated with the operation of data communications services via cable television networks. Chapter 5 outlines the policy context and proposes how the regulatory framework of cable television might be most suitably adapted to data communications applications. In Chapter 6 we integrate the technical and regulatory details presented in earlier chapters. This chapter serves as a guide for city cable authorities to incorporate the technical detail and regulatory structures necessary for data communication services into existing cable policy. It emphasizes that not all two-way cable communications technologies are equally adequate for the full range of data communications applications and therefore, in addition to dictating operational policies, the cable authority must review the network design proposed by the operator, to insure that suitable facilities are in place.

# **Chapter Two**

## **Cable Television**

**as a**

### **Data Transmission Medium: Tutorial**

In this chapter we present a tutorial on the technical aspects of cable television networks as applied to two-way data communications. We review the hardware components of both traditional and enhanced cable networks and describe the communications protocols that can be brought to bear when implementing two-way data communication services. We conclude with a discussion of the primary technical limitations to implementation of two-way data communications. It is found that the communications protocol largely determines the capability and performance of the two-way system, given the limitations of upstream noise and low reliability.

Cable Television systems, also referred to as Cable (Community Antenna Television, CATV) systems, were designed to distribute television signals from a central location to residential homes throughout a local region. These systems were used originally to provide entertainment television to regions where off the air reception was not satisfactory. Increasingly, they are used to provide a greater diversity of programs than spectrum limitations permit, and as a means of delivering pay-television.

Although one-way television signal distribution continues to be the primary application of cable systems, the technology is also appropriate for two-way communications. Two-way systems are those which carry signals from subscribers back to the headend (*upstream*), in addition to distributing signals from the headend to subscribers (*downstream*).

The two-way data communication capabilities of cable technology have been most extensively exploited in private Local Area Communication Networks (LACN's). These

networks transmit two-way video and data throughout large buildings, industrial plants, and campuses. This report focuses on developments in two-way data communications over *city-wide* cable systems, as opposed to *campus-wide* systems.

Cable networks are of two types: *residential* and *institutional*. Residential networks distribute video entertainment programming to residential subscribers in rural, suburban, and urban areas. In contrast, institutional networks are located in city centers and serve business needs of commercial and governmental subscribers.<sup>11</sup> Residential networks carry most of their traffic downstream in support of their primary service, video entertainment. However, newer services, such as home security, interactive videotex, and transaction services, require an upstream capability. Institutional networks, given their business clientele, will typically experience a more even distribution of communications to and from subscribers. Proposed institutional services include high speed two-way data communications, in addition to closed-circuit television, for education and teleconferencing.

## 2.1 Cable system components

This section describes the elements which comprise a cable system. The first part describes those hardware components common to all cable systems. We then describe the additional hardware necessary for the provision of two-way data communications.

### 2.1.1 Basic cable systems

**All cable systems are composed of a headend, a distribution plant, and interface equipment.**

In a traditional video distribution cable network, the headend receives over-the-air broadcasts and translates them to frequency bands that are appropriate for transmission onto the cable plant. Programming material that is prepared especially for cable is generated at the headend and is also transmitted onto the cable plant. The cable distribution plant is a tree-like configuration of broadband coaxial cable, amplifiers, bridges, and feeder cables. The signals travel, via the distribution plant, to the subscriber's home, where the interface equipment translates the signals into a form receivable by the subscriber's television (Figure 2-1).

---

<sup>11</sup> Only a few institutional networks are currently operational.



free, steady signal is transmitted onto the network. Some headends also phase lock the frequency offsets of incoming signals to reduce visual interference among them.

#### 2.1.1.2 Cable distribution plant -- cable, amplifiers, bridging amplifiers

The cable plant is comprised of broadband coaxial cable, signal amplifiers, and bridging amplifiers. All transmission over cable networks is *Frequency Division Multiplexed (FDM)*, i.e., the total frequency spectrum of the cable is subdivided into channels. Each channel allocation is typically equal to a standard television channel, 6 Mhz. The bandwidth that can be transmitted over coaxial cable is largely determined by the amplifiers used. The cable itself has a bandwidth in the giga-Hz range but the active components, namely amplifiers, are limited in the bandwidth that they can transmit without causing excessive cross-talk<sup>13</sup>.

The amplifiers used on older cable systems transmit less than 300 Mhz which limits their carrying capacity to between 12 and 20 channels; these systems make up more than 50% of the cable systems in use today<sup>14</sup>. With appropriate engineering, newer systems, whose components transmit 300 Mhz, will carry up to 30, 6 Mhz (TV) channels; systems whose components transmit 400 Mhz will carry up to 52 TV channels. One problem experienced with 400 Mhz, and higher, amplifiers, is that due to the extra channel loading there is a degradation in the composite triple beat rating of the amplifiers [34], [5]. The triple beat phenomenon is caused by different frequencies interfering with one another and generating noise; in particular, the sum and difference frequencies produced from the product of three frequencies<sup>15</sup>. Three different types of coaxial cable are used in most systems -- trunking cable; narrower and more flexible distribution cable for network branches; and feeder cable which carries the signal to each individual household from the distribution cable. The latter two cable types have greater attenuation than that of trunking cable but are less expensive. Optimal network design attempts to minimize their use within cost constraints.

---

<sup>13</sup> Cross-talk refers to the undesired transfer of energy from one channel to another.

<sup>14</sup> NCTA statistic, 1981, Wendell Bailey

<sup>15</sup> The triple beat phenomenon, also known as third order intermodulation, is the beating of one signal carrier with the second harmonic of another signal carrier ( $2f_1 \pm f_2$ ) or the beating of three signal carriers together with or without modulation ( $\{(f_1 - f_2) \pm f_3\} = f_3 \pm 6 \text{ Mhz}$ ).

Amplifiers are placed throughout the cable plant to compensate for attenuation which occurs when a signal is transmitted over long distances. The number of amplifiers needed per mile of distribution plant depends on the attenuation characteristics of the cable. An amplifier cascade refers to the number of amplifiers which a signal passes through between its source and destination point. Because all amplifiers contribute some distortion to the signal, there is a strict upper limit to the length of a cascade which can be tolerated before the signal becomes distorted beyond acceptable levels. In addition, the wider the bandwidth of an amplifier, the more difficult it is to control signal distortion. Therefore, the maximum tolerable cascade for 400 Mhz systems is smaller than that for 300 Mhz systems [59]. All branching is achieved with the use of *bridging amplifiers* which feed amplified signals from the trunk cable onto a distribution cable while keeping the trunk cable electrically isolated.

The *geographical coverage* of a cable network is limited by the signal loss over the cable, and by the distortion characteristics of the amplifiers. The systems described in this report operate over areas of 7 to 50 miles in diameter. For the case of 400 Mhz components, the maximum allowable amplifier cascade limits the diameter of single hub systems to about 10 miles.

The cable distribution plant is typically arranged in one of three topologies, referred to as loop, tree, and hub. A *loop* design resembles a snake and requires the fewest of amplifiers, but entails the longest amplifier cascades. The cascade of a loop design network is proportional to the total distance which the cable traverses. For this reason, the loop topology is only appropriate for systems with limited geographical coverage and the low distortion characteristics ordinarily associated with small channel capacity.

A *tree* system is composed of a winding central trunk and branching distribution cables that carry the signals closer to the subscribers' premises (Figure 2-2). This topology reduces the total number of amplifiers needed, and allows the system to serve a larger area than a loop topology. It also allows isolation of portions of the cable plant in cases of disruptive component or interface unit malfunction, i.e., individual network branches, without halting total system operation.

The inferior characteristics of 400 Mhz amplifiers restrict the topology of 400 MHz systems to a *hub design* whose branches are shorter than those of tree structures (Figure 2-3). This configuration resembles a star with the headend at its center, and multiple radially distributed



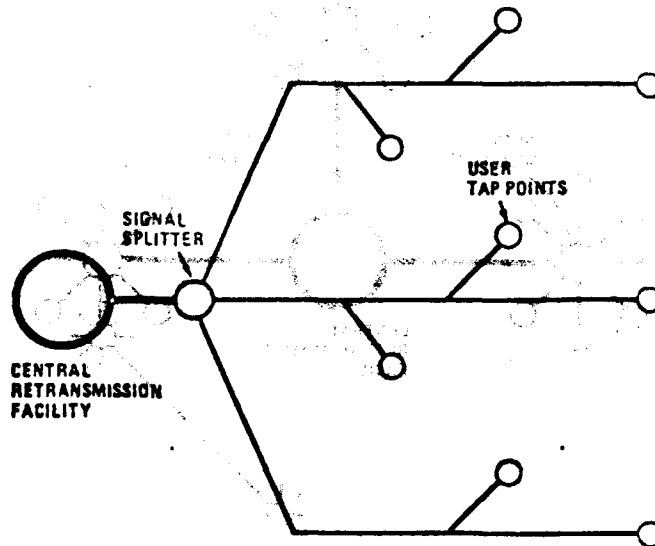

Figure 2-2: Tree Topology (*Data Communications*<sup>16</sup>)

trunks. The maximum distance between the farthest subscriber and the headend is thereby minimized. This reduces the length of the amplifier cascades necessary to cover a given geographical area. Systems can be configured with multiple interconnected hubs to cover larger geographical regions. Enhanced transmission methods that are more resistant to noise and inter-modulation are used to connect the hubs (e.g., digital transmission, frequency modulation, wider guard bands). Wideband, low-attenuation media, such as microwave or fiber optics, are typically used for the inter-hub links. These methods and media are currently economically prohibitive for use in other segments of the cable plant.

### 2.1.1.3 Interface equipment

The feeder cable taps off of the distribution cable and carries the signal to the subscriber. The interface unit, which is also referred to as the customer premises equipment (CPE), connects the feeder cable to the customer's TV set. The interface unit translates the signals taken off of the cable to a frequency band that can be received by a standard television. This converter is the simplest form of cable interface unit. In addition, subscribers to pay-television programs, which are sometimes scrambled before transmission, have converters

<sup>16</sup>Dineson, M., Picazzo, J. [22]

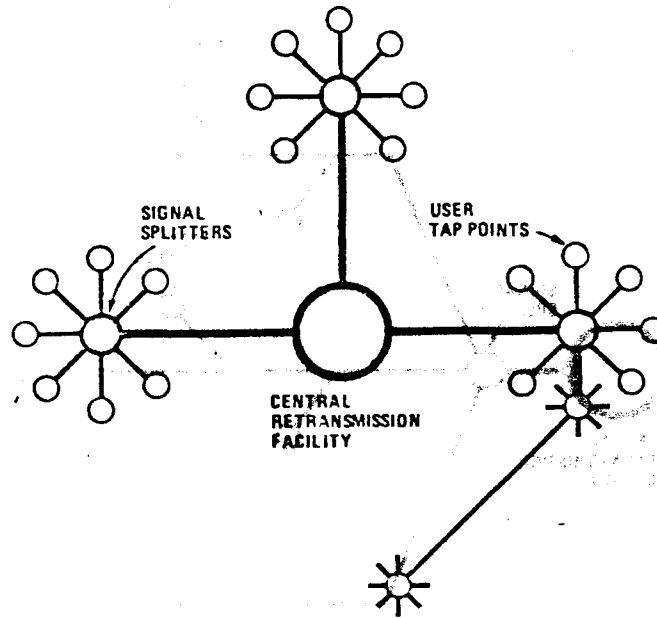

Figure 2-3: Hub Topology (Data Communications<sup>17</sup>)

equipped with descramblers<sup>18</sup>.

## 2.1.2 Two-way cable system components

### 2.1.2.1 Headend

Two-way communications on a cable system requires that the headend receive upstream signals from the cable distribution plant in addition to transmitting signals downstream. Some of the control structures for data communications require only that the headend translate specified upstream signals onto select downstream channels. Others depend upon the headend for additional addressing and switching capabilities. Some of the upstream signals may be forwarded by the headend to other points on or off of the cable network, while others may be destined for the headend itself. Exactly what equipment is needed depends on the application. To ensure compatibility with video transmissions, some headends also frame the data signals to look like video.

<sup>17</sup> Dineson, M., Picazzo, J. [22]

<sup>18</sup> Alternatively, the pay-television signals are trapped out at the trunk connection to each subscriber's feeder cable who does not pay for the premium service.

Most large systems today, both one-way and two-way, employ a minicomputer at the headend for system control, maintenance, and billing. Once the headend is so equipped, numerous network management functions can be implemented at the headend.

#### 2.1.2.2 Cable distribution plant

Two-way capability implies that the cable distribution plant transmits signals in both directions. The coaxial cable itself has this capability but, the standard one-way cable amplifiers must be modified to accommodate two-way transmission.<sup>18</sup> Two-way amplifiers amplify a portion of the cable's frequency spectrum in the upstream direction, and the balance in the downstream direction. The upstream and downstream portions need not be of equal bandwidth, and in most cases are not. The frequency bandwidths allocated for upstream and downstream transmission are completely determined by the amplifiers used. Any one-way system can, in principle, be converted into a two-way system if the amplifiers are replaced with two-way amplifiers<sup>20</sup>:

Two-way cable systems vary in the number of channels allocated to upstream communications. Residential systems typically allocate most of their cable channels to downstream transmission -- 54 Mhz to 300 Mhz for downstream, and 5.75 Mhz to 29.75 Mhz<sup>21</sup> for upstream, transmissions on 300 Mhz systems. These are referred to as *subsplit* systems. Most institutional cable systems, as well as private LACN's, are *midsplit* systems. These allocate the same number of channels to both upstream and downstream transmission; for example, 5.75 Mhz to 108 Mhz for upstream (reverse), and 162 Mhz to 300 Mhz for downstream, transmission on 300 Mhz systems. These frequency assignments are somewhat arbitrary, using over-the-air T.V. transmission frequency assignments so as to take advantage of widely available (and therefore inexpensive) amplifiers and related equipment. Some cable systems, referred to as *dual cable*, use two cables. The cables can be operated as two subsplit or midsplit systems, or one of each. A fourth option uses an entire cable for

---

<sup>18</sup> The amplifiers on two-way ready systems have slots ready for insertion of upstream amplifier boards. This technique was prescribed by the FCC in the mid-seventies for all large cable systems. It was an attempt to minimize the cost of future retrofitting, while recognizing that a two-way market did not yet exist. Cf. Section 2.1.2.2

<sup>20</sup> See Section 2.3 for other practical limitations to two-way transmission.

<sup>21</sup> Channels T1 - T4 using standard cable nomenclature

downstream, and operates the second cable as either midsplit, or subsplit, or entirely upstream<sup>22</sup>.

The data transmission rate achieved on each channel is determined by the number of bits per hertz (bits/hz)<sup>23</sup> transmitted. This in turn is affected by the noise limitations (see Section 2.3), and the sophistication (and cost) of the modem. The data rate experienced by each user is also determined by the access scheme used (see Section 2.2), as well as the geographical coverage. Existing cable based data communication networks achieve aggregate data rates up to 5 Mbps over each 6 Mhz channel (0.833 bits/hz), depending upon the access scheme and geographical coverage<sup>24</sup>. Aggregate data rates achievable over the full spectrum of a midsplit cable system range upwards of 300 (300 Mbps is an arbitrary example of the data rate achieved assuming 0.5 Mbps per 6 Mhz channel). In comparison, Multipoint Distribution Systems (MDS), which use microwave transmission facilities, offer at most one or two 6 Mhz channels due to limited over-the-air spectrum availability; and unmodified, telephone company, local loop facilities (twisted wire pairs) offer up to 4.8 Kbps.

Two-way bridge amplifiers are used to amplify signals onto, and off of, segments of the cable plant which branch off of the central trunk. In some two-way systems the bridge amplifiers are equipped with added electronics which allow them to be addressed and switched on and off via signals from the headend. In more sophisticated two-way systems, bridges might be equipped to perform diagnostic checks on the network as well.

### 2.1.2.3 Interface units

The interface unit for a two-way system must convert signals from the terminal into a form that can be transmitted over the designated cable channel, and received by the headend. The function and complexity of the interface unit depends upon the type of terminal and access scheme used. The interface unit consists of two parts, one is the rf modem, and the other is the control logic (both digital hardware and software)

---

<sup>22</sup>Wang uses a dual cable for its Wangnet and claims to achieve three times the bandwidth at 20% additional cost.

<sup>23</sup>Bits per hertz is the inverse of the efficiency rating, or hz/bit. Bits/hz is felt to be a more useful measure in this instance and will be used throughout the report.

<sup>24</sup>Cox Cable's Indax system runs at 28 Kbps over 125 Khz subchannels (.223 bits/hz). Wang's broadband system runs over shorter distances at speeds up to 12 Mbps over an 18 Mhz channel (0.667 bits/hz). Uegermann-Bass runs at 5 Mbps per 6 Mhz channel (0.833 bits/hz), over distances up to 10 miles.

*Radio frequency modulator-demodulators (rf-modems)* convert digital signals from digital devices into analog signals which can be carried by the cable network much like video signals. Rf-modem technology has proven very popular for industrial use, and more recently for communications in business environments; however, it remains a relatively costly technology for residential use. Rf-modem costs range upwards of \$400. This high cost is partially due to the limited quantities currently manufactured. In addition, the analog complexity of radio frequency components makes Large Scale Integration (LSI) difficult; therefore, the costs are not expected to decrease as rapidly as many digital components.

In a telephone system every customer has its own dedicated wire pair; on a cable television network nodes share a common trunk which passes many households. An access scheme or protocol controls how the cable capacity is shared. Each unit must also be given an unique digital address to identify it for reception of downstream signals. Thus, in addition to the rf-modem a two-way interface unit contains control logic which implements the communication protocol. The interface unit design and cost is largely determined by the access scheme used on the network. Finally, the interface may implement additional capabilities such as anti-jamming techniques, encryption, or other enhanced features.

## **2.2 Access schemes and communication protocols for two-way data communications**

A number of alternative protocols for data communications over broadband cable have been implemented. Each of the protocols has a system structure and user environment for which it is most appropriate. Residential and institutional networks may require different schemes, based on the differences in their applications. Eventually, agreed-upon standards will be needed to support interconnection of networks with dissimilar higher level protocols.

### **2.2.1 Description of access schemes**

#### **2.2.1.1 Polling**

The most common access scheme currently used for two-way communications on cable systems is *polling*. The headend continually cycles through the system, addressing a

message to each interface unit to see if it has data to send. It can take as long as 6 seconds to poll every user in a large system, on the order of 100,000 subscribers<sup>25</sup>. Unique digital addresses are hard-wired or programmed into each of the subscriber interface units.

The performance of a polling scheme is characterized by the response time realized by the subscriber and the amount of data sent per response. Some polling schemes allow the polled device to reply to the headend only with one of a set of predefined responses; others allow more flexibility in the allowed length of the response. Polling is most often used for pay-per-view billing, as well as for security and energy monitoring applications. Polling methods are appropriate for transaction services and other data communications services only when traffic is very light, and when response time is not critical.

A modified version of polling uses *intelligent bridge-switches*. The headend polls one branch of the network at a time by addressing the appropriate intelligent bridge amplifier and allowing all nodes on that branch to simultaneously transmit (using separate, preassigned frequencies) their upstream signals onto the entire upstream portion of the trunk cable. Since only one branch is allowed to transmit at a time, the entire upstream channel spectrum can be used by the nodes on a single branch. This method achieves higher data rates than most simple polling schemes but may still suffer from long response times due to the polling cycle.

*Binary polling* is used to decrease the delay which results from long polling cycles. The headend sends out polling messages to all points on the network. If the headend receives a response it locates the responding device (or one of them) using a binary search technique. The headend turns off half of the network branches and polls the other half. If there is no response, the originally responding device is known to be on the other half of the tree. The network is configured as a long branching tree and this divide-in-half process continues until the headend has isolated one responding node on the network. The customer is serviced and the process begins again. This method is only effective in reducing delay if there are few simultaneous users with messages to send, e.g., security monitoring.

---

<sup>25</sup>The Minneapolis cable system being built by Rogers Cablesystems Engineering of Canada, specifies a 6 second polling cycle.

### 2.2.1.2 FDM

*Frequency Division Multiplexing (FDM)* can be used to divide each of the 6 Mhz channels into smaller subchannels for dedicated use by subscribers<sup>26</sup>. The FDM interface unit is a standard rf-modem tuned to dedicated frequencies, one for transmitting and one for receiving. The receiving frequency serves as the unit's digital address. The data rate is a function of the channel bandwidth and the number of bits per hertz transmitted.

*Switched FDM* schemes resemble the current architecture of the telephone system. Each user is assigned a dedicated subchannel. This frequency assignment serves as the user's address. The headend reads addressing information on upstream communications and routes the information to the proper downstream subchannel, performing the appropriate frequency translation. This access method is appropriate for systems with a limited number of users whose communications are relatively uniform over time. The number of users who can be served by such a scheme is limited to the number of available subchannels, which in turn is limited by the minimum acceptable bandwidth of a subchannel. This is far fewer than the number of residential subscribers on even a small two-way system (3,500 or more), but is possibly adequate for an institutional system.

*Dynamic assignment FDM* makes use of frequency agile modems which allow users to transmit via one of a set of frequency subchannels; the particular frequency used is determined by the user or by a central controller, i.e., the headend. The central controller dynamically assigns the calling and called nodes a free subchannel for the duration of their communications; polling can be used to identify the node that wishes to set up a connection. While allowing service to many more users, this method is still less suited to bursty traffic types such as computer communications which is characterized by short, high intensity, intermittent communications. Using FDM alone as the access scheme<sup>27</sup>, when a channel is assigned to a device, even if dynamically assigned, it will lay idle during those times when the device has no data to transmit.

---

<sup>26</sup> Manhattan Cable Television (MCTV) in New York city uses this approach. MCTV has operated a data transmission service between uptown and downtown Manhattan since 1975. The service is primarily used by banking and other financial institutions with branches in both locations.

<sup>27</sup> Note that all cable television uses FDM to divide the 300 or 400 Mhz of bandwidth on the cable.

### 2.2.1.3 TDM

*Time division multiplexing (TDM)* allows multiple devices to share a single FDM channel or subchannel by assigning each user a fixed time slot during which it sends its data. A user's address is his time slot. A form of TDM called *Time Division Multiple Access (TDMA)* allows many devices along a cable to share a TDM channel; devices insert data into their slot at multiple points along the cable. There are a number of methods for controlling allocation of the time slots using a TDMA scheme. *Demand Assigned-Time Division Multiple Access (DA-TDMA)* is a more sophisticated TDMA scheme which allows dynamic allocation of time slots on a transmission channel. This technique was developed for satellite communications, and is generally applicable to high bandwidth *multipoint communications networks*. DA-TDMA uses intelligent microprocessor controlled interface units, as well as a fairly powerful minicomputer at the headend, to allocate time slots on an as-needed basis. DA-TDMA is appropriate for both high and low speed users, particularly users with high volume requirements.

### 2.2.1.4 Contention schemes

Contention Schemes are another form of TDMA. Aloha [1], Carrier Sense Multiple Access (CSMA), and CSMA with Collision Detect (CSMA-CD) [41] are all candidates for use on residential cable systems. Contention schemes allow all users to share a single channel, or multiple subchannels can be interconnected using a bridging device. For example, using CSMA, when a device has data to send, the interface unit broadcasts packets of information onto the channel. If the unit does not receive an acknowledgment that the packets were received intact (i.e., a collision occurred when two or more units attempted to use the channel simultaneously, resulting in destroyed packets), it retransmits the packets. The more sophisticated schemes allow the devices to detect other traffic on the channel before or during broadcasting, thereby reducing the probability of collision. For example, using CSMA-CD, if more than one device broadcasts at any one point in time, there is a collision and both devices backoff and try again after some short but random period of time. Every device scans the address destination attached to each packet on the channel but reads only the contents of those packets that are addressed to it. Contention systems present a tradeoff among data



rate, geographical coverage, and minimum packet size<sup>28</sup>. Although LACN contention systems operate at speeds as high as 5 Mbps per 6 Mhz channel<sup>29</sup>, peak data rates for a residential cable are probably limited to 1 or 2 Mbps per 6 Mhz channel (0.166 to 0.332 bits/hz), due to wider geographical coverage and lower guaranteed signal to noise ratios<sup>30</sup>.

Contention schemes achieve complete connectivity through distributed control. In contrast to DA-TDMA, contention systems require no added complexity at the headend beyond signal conditioning; the switching function is inherent to the way in which the channel is shared. This reduced complexity and distributed control is very attractive for the diverse community of users that is to be served in the residential and small business market. Contention systems are appropriate for multipoint communications between bursty users at medium and high speeds, and short to moderate length messages.

*Token passing* is a distributed polling method. The IEEE LACN standards committee<sup>31</sup> describes the token access method as follows [32]:

**A token controls the right of access to the physical medium; the node which holds (possesses) the token has momentary control over the medium.**

The token is passed by nodes residing on the medium; it is passed from node to node in a logical ring fashion.

Steady state operation consists of a data transfer phase and a token transfer phase. The two phases may be combined, in which case the token is transferred in conjunction with a data frame (implicit token).

Monitoring functions within the active nodes provide a basis for initialization, recovery, and general housekeeping of the logical

---

<sup>28</sup>Estrin, D., *Some Technical Considerations in Using a 400-MHz CATV System for Data*, Working Paper, Laboratory for Computer Science, M.I.T., May 1981.

<sup>29</sup>Ungermann-Bass Inc. [63], *Net/One Broadband*; Wangnet achieves 12 Mbps over 18 Mhz, or 4 Mbps per 6 Mhz.

<sup>30</sup>Dickenson [21] suggests that well-maintained systems should experience signal to noise ratios of 40 dB or greater, which is more than adequate for high performance. But, there are no statistics currently available as to the number, or percentage, of residential cable systems that fit this description. In addition, the residential cable system is exposed to a harsher, and less controllable, environment than a building-wide LACN is, making it difficult to guarantee performance.

<sup>31</sup>Institute of Electrical and Electronics Engineers, Project 802, is attempting to set standards for local area network communication protocols. Standards have been established for both contention and token access methods [32].

ring. The monitoring functions may be replicated among nodes of the network, but only a few nodes at a time carry the primary recovery responsibility.

As on the contention channel, packet headers are scanned by all interface units on the channel but are selected by only that unit to which they are addressed. In contrast to the contention method described above, this method does not present the speed, distance, packet length trade-off. It therefore can be used to achieve higher speeds over longer distances. In addition, the performance of a token passing channel does not degrade under heavy loading as severely as does a contention channel. On the other hand, if the channel is lightly loaded, longer delays will be incurred with higher probability; this could be aggravated by extended geographical length of the channel and poses an upper bound to the geographical coverage [54]. A central monitor station is ordinarily used to ensure the integrity of the token, i.e., that it does not get lost or duplicated. This monitor could be located at the headend<sup>32</sup>.

## 2.2.2 Performance characteristics of access schemes

The choice of access scheme presents a tradeoff among *throughput*, *connectivity*, *availability*, and *cost*.

### 2.2.2.1 Throughput

The throughput is the data rate experienced by an individual user. It is only a portion of the aggregate data rate offered on the channel. Polling typically offers the lowest throughput to the user. Some implementations of bridge-switch polling allow a single branch to make use of the entire upstream channel capacity at a time. Although this increases the peak data rate accommodated, the polling-cycle delays effectively reduce the throughput experienced by the subscriber.

The throughput experienced on a dedicated FDM channel is equal to the data rate of the modem used. Higher data rates require more dedicated bandwidth, limiting the number of users who can be served in a given frequency allocation. Sending fewer bits per hertz results in cheaper modems but the inefficient use of bandwidth limits the amount of traffic that can be accommodated.

---

<sup>32</sup>Phase-locked regenerators would be used along the channel to ensure proper transmission of the token.

The throughput experienced by a single device on all varieties of TDMA channels is determined by the number of devices served on the channel, i.e., the load factor, since the channel rate is usually equally divided among all nodes. The throughput is also determined by the channel bandwidth allocation, and the specifications of the interface hardware.

#### 2.2.2.2 Connectivity

Connectivity is the ability to communicate with every other point on the network. This requires that each point have a digital address and that communications can be transported from each point to every other point on the network, i.e., unique addressing and switched services.

Polling is not well suited to multipoint-to-multipoint communications, because the task of collecting and forwarding messages, is cumbersome. Polling is best applied in systems where multiple distributed devices need to communicate with a single central device which executes the polling and processes the messages (See Section 3.2.2.2).

FDM channel services can resemble point to point dedicated telephone lines which only achieve connectivity between a pair of points, or multidrop lines which allow a transmitting device to communicate with multiple listening devices. Switching can be implemented at the headend in much the same way as the telephone company to achieve complete connectivity.

The facilities at the headend of the DA-TDMA system, i.e., a computer and the appropriate software, typically implement switching as well as allocation of time slots. Although switching is not inherent to DA-TDMA, it can be assumed that such systems can achieve complete connectivity.

Contention access scheme protocols achieve complete connectivity among all nodes on a channel. Multiple contention channels using different frequency bands require additional facilities for complete connectivity across the system. A bridge is a device used to connect otherwise independent channels on a network by translating specially addressed packets from the one channel to the other<sup>33</sup>.

---

<sup>33</sup>This type of bridge is distinct from the bridging amplifier described earlier which translates electrical signals from the cable trunk onto a branch of the cable system.

### 2.2.2.3 System availability

The availability of a system is largely dependent on the complexity of the control and interface equipment. The more complex the equipment, the more limited are replacement parts, the more difficult are organizational and technical procedures for operation and maintenance, and the more frequent and lengthy is the average downtime.

Protective measures from both intentional and unintentional interruption of the communication channel are required to assure system availability. The susceptibility of the network to jamming is partially a function of the access protocol used. Point-to-point, dedicated FDM lines are less susceptible to accidental disruption by users because there is only one designated user per channel; the user's equipment, even if it jams, is likely to disrupt no more than the single channel to which it is assigned. DA-TDMA, and contention schemes allow multiple users access to a common channel, thereby increasing the likelihood with which a malfunctioning interface unit can disrupt service to others. In both cases, where system availability is valued, monitoring and detection schemes should be implemented at the headend, in the interface units, or at designated points in the cable network, to assure that jamming devices can be isolated from the network either by turning them off or by turning off that branch of the network.

### 2.2.2.4 Relative costs of access schemes

The communications costs associated with each of these access schemes is divided between the central control equipment at the headend and the interface units<sup>34</sup>. The choice between centrally controlled or distributed communication schemes presents a variety of trade-offs. The majority of the centrally controlled communications cost is in the headend equipment. In a distributed system, the interface units are more complex (and therefore more expensive), while the cost of central control equipment is lower. The choice largely rests on the number of devices using the system. When the number of devices served becomes large, it generally becomes less expensive to use a system whose incremental, distributed, costs are low<sup>35</sup>. A second fundamental tradeoff is that of cost and function. Not only does the equipment cost rise with added complexity, but the maintenance costs rise as well.

---

<sup>34</sup> Actual equipment cost figures are discussed in Section 3.3

<sup>35</sup> This is not true if the cost of the central control equipment increases significantly with the number of devices served.

The interface unit is comprised of an rf-modem and digital logic which implements the communication protocols. The cost of the rf-modem is a function of the frequency bandwidth over which it transmits and the number of bits per hertz transmitted. The cost of the digital logic is a function of the complexity of the communications protocol used.

Of all the centralized communication schemes polling is the simplest and therefore requires the least expensive central control and interface equipment. Centralized equipment is typically an inexpensive minicomputer with appropriate software. The rf-modems used in these low speed devices are relatively inexpensive, as is the digital logic.

FDM interface units require only minimal control logic. Their cost is primarily a function of their transmission speed. As rf-modems are manufactured in larger quantities, the cost of FDM units will drop significantly. Only frequency translation is necessary at the headend for point-to-point FDM communications, while the equivalent of a telephone switch is required for switched FDM services.

TDM units with fixed time slot allocations also require centrally controlled switching but only a modest amount of control logic in the interface unit.

DA-TDMA requires sophisticated logic in the interface unit, as well as sophisticated control at the headend for time slot allocation. Contention schemes require sophisticated logic in the interface units but no central control beyond frequency translation and signal conditioning<sup>36</sup>. The relative economics of contention and DA-TDMA systems of equal speeds depends largely on the number of users served and their traffic volume.

## 2.3 Cable system limitations

Privately constructed and operated industrial and campus broadband networks, LACN's, can come close to realizing many of the favorable communications features described above; the same cannot be said about existing cable networks. The problems are both of technical and institutional origin. The following constraints will hamper implementation of economical, high speed data networks over cable television systems:

---

<sup>36</sup> Network management functions for a contention system may be implemented in a centralized headend facility, but unlike many other access schemes, such a facility is not necessary to basic system operation.

## **- Technical**

- \* **Ingress and insertion noise due to poor construction and maintenance of cable systems.**
- \* **Reliability and security problems due to the difficulty of locating the fault or source of interference on the network.**
- \* **Compatibility with video transmission.**

## **- Organizational**

- \* **Lack of common cable network specifications and communications protocols which preclude the use of standard approaches or equipment, therefore not providing economies of scale.**
- \* **Large investment necessary to retrofit existing system amplifiers and headends to accommodate two-way switched services.**
- \* **Large investment necessary to wire cities and buildings.**

### **2.3.1 Noise and corrective measures**

Two types of noise problems on two-way cable systems are insertion noise on the upstream channel and ingress noise into "leaky" cable systems. Noise is important because it limits the data carrying capacity of a cable network. Noise enters the system at many points along the cable plant. In Figure 2-3, twelve noise sources are identified: receiving antenna at headend, headend, local origination studio, the trunk cable (largest diameter cable; shielding provides high noise immunity), leakage at the trunk amplifier, leakage at the bridging amplifier, the feeder cable (narrower, and therefore lower noise immunity than trunk cable), leakage at the tap, the drop cable (narrowest, and lowest noise immunity cable), the interface unit, and the communicating device (computer or television set), leakage at the line extender amplifier.

#### **2.3.1.1 Insertion noise**

The noise on the upstream channel in the vicinity of the headend is the sum of all the noise "inserted" by all the units which tap onto that channel and the insertion noise from every amplifier between the farthest subscriber and the headend. Thus the longer the distance between the subscribers and the headend, the greater the noise relative to the signal.

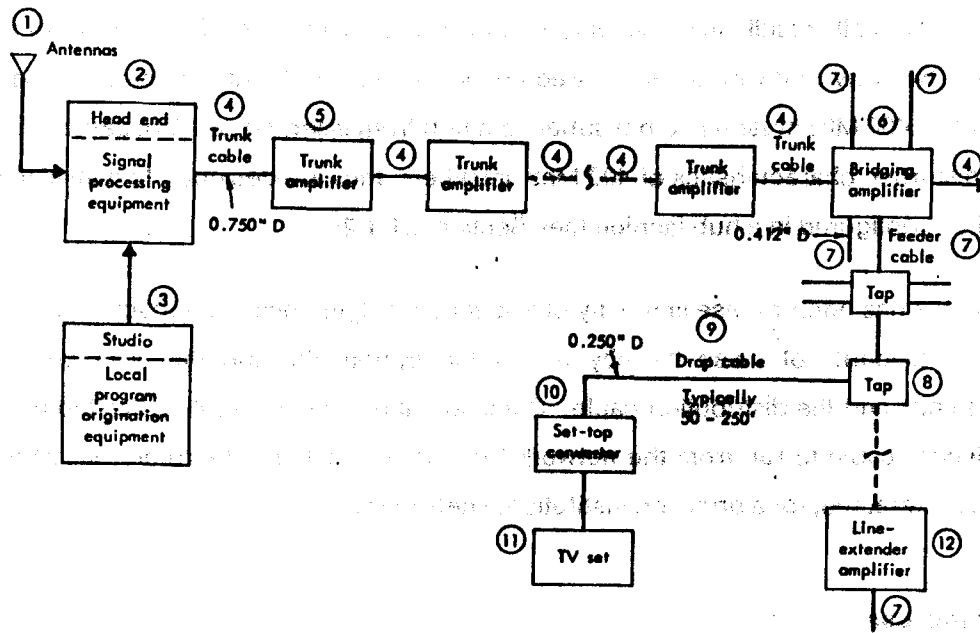

**Figure 2-4: Sources of signal noise and interference (Cable Television: Franchising Considerations<sup>37</sup>)**

1. Antenna at headend.
2. Headend.
3. Local origination studio.
4. Trunk cable.
5. Trunk amplifier.
6. Bridging amplifier.
7. Feeder cable.
8. Tap.
9. Drop cable.
10. Interface unit.
11. Communicating device.
12. Line-extender amplifier.

<sup>37</sup>Baer, W. [8]

Existing 300 Mhz residential systems are typically configured to minimize the total number of amplifiers needed, as opposed to the length of the maximum branch, or amplifier cascade. This design typically results in some long, noisy upstream channels. The majority of two-way active and two-way ready systems are tree configurations, and many continue to be built in this fashion. 400 Mhz systems do not suffer as much from insertion noise because, due to the inferior distortion characteristics of 400 Mhz amplifiers, they are designed to minimize branch length, i.e., configured in a hub fashion (see Section 2.1.1.2).

Feeder cable has poorer noise immunity characteristics than does distribution or trunk cable. Significant amounts of noise thereby enters the system through the links between the interface units and the distribution cable. Commercial users can usually afford to use higher quality feeder cable to run from the network trunk to the building; therefore, insertion noise can be counteracted, for a price, on institutional networks.

### 2.3.1.2 Ingress

Loose connections, for example at a subscriber tap, can allow the *ingress* of outside signals or noise. This leakiness is first of all due to poor mechanical design and engineering of the cable plant. Even if a system is carefully installed, the connectors need to be tightened regularly or significant leakage will develop. Connectors typically begin to leak six months after installation due to the effects of temperature variations on component materials. It is difficult to engineer around a leaky system, on anything other than a case-by-case basis, because the noise which results is not randomly distributed; therefore, commonly used engineering techniques cannot be brought to bear. C-B and Ham radios near a leaky cable system can cause complete disruption of communications in the lower part of the cable spectrum<sup>38</sup> [4]. In extreme cases, intermodulation into other video bands can occur<sup>39</sup>.

A related problem is interference of data signals with television signals on the cable. Noise levels as low as 60 dB below the television carrier can cause television interference. Although the power levels of the television and data signals must be carefully balanced,

---

<sup>38</sup>This lower portion of the frequency spectrum is typically designated for data transmission on subsplit systems

<sup>39</sup>Intermodulation results in signals generated at frequencies equal to the sums and differences of the signals that are interfering with one another.



experience has shown the problem of cross-channel interference to be controllable. Systems are typically designed to transmit data at power levels approximately 18 dB below the level of the TV signals. Problems of cross channel interference are likely to be somewhat more significant on older residential systems than on newly installed residential or institutional systems because of inferior construction and components. In particular, amplifiers tended to be designed to weaker specifications than they are today because the electronic components were more costly. In addition, the older systems with smaller channel capacity performed quite well with less demanding practices of construction and maintenance.

It is possible that channels that are unusable for video transmission can be used for data transmission. In particular, channels 14, 15, 16, and 41 cannot be used for video because of interference to aircraft communications; data signals that are properly placed may not create such interference. Similarly, each community cable system is unable to transmit via the frequencies used by local television broadcasters because of interference from the over-the-air signals; data signals may be more immune to this interference than are video signals.

#### 2.3.1.3 Corrective measures

Some of the noise problems -- both insertion and ingress -- can be alleviated through careful engineering and network design. In addition, the noise level can be contained via an aggressive maintenance schedule, for example, tightening loose connectors to alleviate the ingress problem. On the other hand, tightening connectors is a labor-intensive operation and it alone does not assure acceptable ingress levels.

Bridger switching was described previously in connection with a polling access scheme. Bridger switches were originally intended to limit upstream traffic to one branch at a time so as to limit the insertion noise that accumulates on the multiple branches of tree structured systems. Intelligent bridger switches with microprocessor control can act as subsystem controllers. These controllers can perform services otherwise performed by the headend, and can reduce the cost of individual interface units, through added functions.<sup>40</sup>

*Using bridger-switching in this way significantly constrains the type of communication access*

---

<sup>40</sup>Control-com Corp. refers to the intelligent bridger switches as base microprocessors. They are used for fault detection, jamming detection, traffic monitoring, and security subsystem management.

scheme which can be implemented. In particular, it is incompatible with contention protocols which require the channel to remain open. In fact, bridge switching is only attractive for use with polling access schemes.

An alternative to bridge switching for reduction of noise is the use of *digital regenerators* on the upstream channel. Unlike analog repeaters (amplifiers) which amplify both signal and noise, regenerators extract the data signal and regenerate it without the noise component. Regenerators can only be used on a channel that is transmitting digital data in analog form, as opposed to analog signals such as voice or video that have not been digitized. Not all amplifiers on the upstream channel would need to be replaced by regenerators; the number can be adjusted depending upon system noise levels and the desired SNR. Retrofitting a cable system to use digital regenerators would involve pulling off the desired upstream frequencies, bypassing the upstream amplifier and sending the selected signals through a demodulator, a regenerator, a modulator, and back to the output point of the bypassed upstream amplifier, see Figure 2-4. The telephone company uses T.1 (1.544 Mbps) digital regenerators extensively, which has brought down their cost to approximately \$70 each.

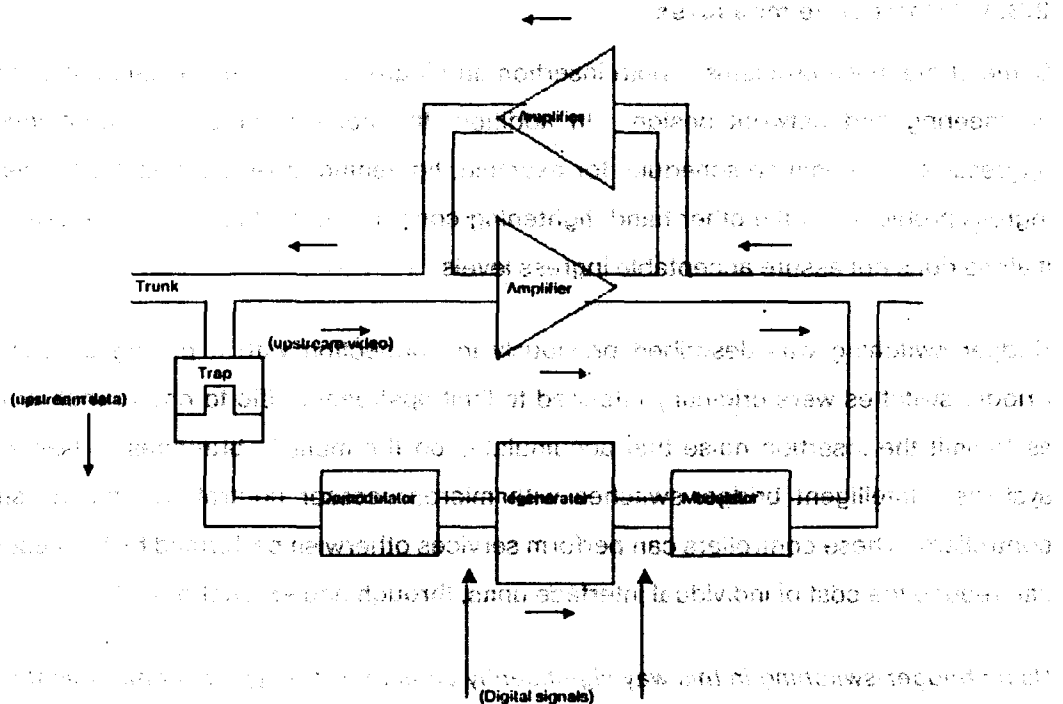

Figure 2-5: Digital regenerator used to reduce upstream noise.

Hub systems have shorter amplifier cascades, resulting in less insertion noise on upstream channels. All future systems, both residential and institutional, should be designed in a hub fashion to reduce upstream noise and to limit the need for additional components such as the digital regenerator described above<sup>41</sup>.

To avoid interference on leaky systems from C-B and Ham radios, channels coinciding with these bands can be avoided. A related alternative is to allow communications circuits to switch from one channel to another if the channel in use becomes unacceptably noisy. This would require frequency agile modems and an additional level of complexity and control capability at the headend.

Another approach is to use a low bit per hertz ratio which allows for increased signal energy relative to the noise. This option is constrained by the available bandwidth. While bandwidth may be plentiful now, it is likely to be an increasingly scarce resource in the future. Finally, more sophisticated -- and expensive -- modems can be used which allow correct signal reception even in the presence of noise.

Some compensation for the high noise level can be achieved through the design of the communication equipment and protocols. Most packet schemes are designed with the expectation that some packets will be lost or damaged and therefore they provide for sensing and retransmission mechanisms<sup>42</sup>.

## 2.3.2 Reliability

### 2.3.2.1 System reliability

The reliability of a communication network is a measure of the availability and quality of service. It depends upon the following network characteristics:

- Noise immunity of the transmission medium.

---

<sup>41</sup>The distortion characteristics of high bandwidth amplifiers mandate limited cascade lengths, therefore all 400 Mhz systems are designed in a hub fashion.

<sup>42</sup>It is important that whatever scheme is chosen should degrade gracefully under conditions of high packet error and retransmission rate.

- *Mean time between failure (MTBF) of system components.*
- Sensitivity of network operation to the failure of single components of the network.
- Susceptibility of the network to jamming.

Broadband coaxial cable (see Section 2.1.1.2) has a higher *noise immunity* than does either baseband coaxial cable or twisted pair. This higher immunity results in specified bit error rates (BER) of  $10^{-8}$  to  $10^{-10}$ <sup>43</sup>. Bit error rate is also proportional to the data rate used, therefore lower speed transmission can be used to overcome noisy systems. Most cable video channels operate at a signal-to-noise ratio (SNR) of 40 dB.

Cable television is a mature technology; individual components tend to be highly reliable. Measured MTBF's for amplifiers are as high as 50 years. Manufacturers guaranteed MTBF's are as high as 20 years [66]. However, failures are not distributed evenly over time. Also, the additive probability of failure of a long cascade of amplifiers is not necessarily negligible.

The headend equipment used in simple FDM or polling data networks is relatively standardized and reliable. Headends that implement complex addressing functions use fairly sophisticated minicomputers. The computers used are not particularly new or risky, but their lifetime, let alone their MTBF, is significantly less than 15 years; in fact MTBF for most computer equipment is measured in days. The reliability of the interface technologies varies. In general, those that have been used most extensively in the field, polling and FDM, are most reliable. They have been well tested and are the least complex.

The most significant reliability problems of technical origin, are:

- The isolation of faults.
- The susceptibility of the network to malicious behavior, *i.e.* deliberate jamming.

Among the primary faults that can occur in the cable plant are conductive shorts, open circuits, and amplifier failures. In the case of conductive shorts, signal tracing techniques are ineffective, and reflectometer processes are not employable because of the amplifiers [66].

---

<sup>43</sup> Modem manufacturers claim that less than 3% of all cable systems actually experience BER's better than  $10^{-6}$  due to degraded signal to noise ratios which result from insertion noise.

Fuses may be placed throughout the cable system to improve reliability, as suggested by D.G. Willard of Mitre Corp. [66].

Mean time to repair (MTTR) is as important a measure as MTBF. Isolation techniques must be engineered, at the interface unit, bridger switch and headend levels, to assure service availability despite component failures. Willard discusses "pilot monitoring subsystems" as a powerful means of identifying and isolating component failures. The use of parallel redundant amplifiers limits the effect of a single amplifier loss to only 6 db. By turning various bridges on and off, one can then isolate which amplifier has the reduced gain. For industrial users, who demand high availability, centrally controlled fault testing may be extended to the customer interface unit as well.

Headend failure brings all communications to a halt. Therefore, it is vital to have resilient, replaceable, and probably redundant headend equipment although this conflicts with the desire for more sophisticated headend capabilities. Aggressive maintenance and protection of the headend is also important. Contention access systems, which require the least complex headend, can be expected to be more reliable than polling or DA-TDMA schemes.

The cable network is vulnerable to a variety of malicious behaviors which interrupt service to network users and are largely unpreventable via technical means. This is part of a general class of problem, called *denial of service*, which is experienced in most computer systems, and satellite communication systems as well. It is a simple matter to alter an interface unit so that it sends a jamming signal on the network thereby denying service to all users on that channel. Fault isolation techniques can aid in the isolation of tampered interface units, thereby limiting the number of users that is affected by the jammer. In a hub design, the headend can determine which of the networks radial trunk the offending unit is using. In a tree design, addressable bridger switches can be used to locate the branch of the offending unit. Eventually, all active components, i.e., line amplifiers, might be addressable so that the smallest portion of the network is disrupted. One example of this problem, is the jamming of an alarm security channel by a burglar who subsequently burgles a neighborhood, or city block, while the alarm service operator is trying to locate the problem. If the offending unit can be immediately isolated to within a block, the alarm system can remain effective; but if it can only be isolated within a neighborhood, i.e., one radial spoke of a hub network, the alarm system is worse than ineffective because of the false sense of security.

It may also be desirable to locate the interface units as far from the user as is possible, perhaps outside of the users' premises. The mere distance would inhibit malicious actions. Currently, interface units are powered from building power supplies, and not from the cable television facilities; thus a power feed would have to be run to the interface unit as well as a communication cable. Sophisticated networking techniques can make use of frequency agile modems to provide alternate routing capabilities to avoid jammed or noisy channels.

### 2.3.2.2 Security and privacy

From the end-users' viewpoint, the responsibility of the communication network is not just transmission of data, but communication of messages and information secure from invasion of privacy. For this reason, network security is often considered as a factor in system reliability. Issues of message content security are not qualitatively different on broadcast cable networks than they are on the traditional telephone network; the precaution taken in both cases will be end-to-end encryption. Nevertheless, for unencrypted text, wiretapping is easier on a broadcast network, where all the traffic passes by every customer.

Susceptibility of the network to traffic analysis, is higher on broadcast packet networks than it is on the star-configured telephone network [36]. Contention schemes, in particular, require that every unit on the network inspect every packet header that is transmitted on the channel so that each unit can detect when a packet is addressed to it. This control scheme lends itself to monitoring of all traffic on the channel. Encryption schemes have not yet been developed which can prevent traffic analysis on broadcast (cable) channels. In particular, this problem can not be addressed on an end-user basis, as can protection of message content through encryption. But, most users do not fear traffic analysis to the extent that such vulnerabilities would deter them from using the system.

In practice, security measures are likely to be left entirely to the user. This means that end-to-end encryption will be implemented, or not, by the end user, and not by the network operator. It also means that there will be no security measures taken against traffic analysis on broadcast channels other than monitoring for foreign devices and wiretapping.

### **2.3.2.3 Institutional roadblocks to system reliability**

Reliability is only partially a technical problem. Therefore, it can only be partially addressed by technical solutions. The level of service demanded by business data communications users will not be met by the quality of service currently accepted by residential television viewers. Fundamentally, the cable industry is still an entertainment provider and is not yet prepared mentally, logistically, or technically to operate to data communication standards. In particular, downtime, technical training, and equipment maintenance will heavily tax the level of expertise and competence common to most cable companies.

## **2.4 Summary**

Two-way cable system hardware differs from one-way system hardware primarily in the level of complexity required at the headend, the type of amplifiers used in the distribution plant, and the interface units used to transmit and receive signals. The communications protocol, also referred to as the access method, largely determines the quality and variety of services available; the selection of a protocol poses trade-offs between complexity, function, and cost. For simple applications (i.e., low speed, point-to-point or point-to-multipoint), minimal-function, low-cost methods such as polling and FDM are best suited. For more demanding applications (i.e., moderate and high speed, any-to-any), contention protocols are better suited and are more economical because of the complexity and cost entailed in enhancing the simpler methods. Most existing cable systems are limited in their applicability to two-way services because of excessive upstream noise and low reliability. The primary source of these problems has been cost-minimizing engineering practices which did not adequately value two-way capability; most of the limitations can be overcome in newer systems.

Having described the basic network components and higher level communication protocols, in the following chapter we will discuss the service structure options and costs associated with implementing data services on cable television networks.

# **Chapter Three**

## **Cable Television**

**as a**

## **Data Transmission Medium: Analysis**

In this chapter we analyze the relative merits of service structure options and their associated costs. The ability to communicate with multiple servers, i.e., not only the cable operator at the headend, is found to be essential for support of future services. We begin with a brief discussion of institutional impediments to the development of data services, the largest of which is the market uncertainty facing the cable industry which inhibits investment in data communications facilities and expertise.

### **3.1 Impediments to Data Service Development**

Data communication services will not succeed until the subscriber market reaches a critical mass. On the other hand, large numbers of cable systems will have to be upgraded to two-way active status before this critical mass develops. A "chicken and egg" syndrome develops, in which the cable operator does not want to invest in two-way construction without assurance of a market, but the market cannot develop without such construction. An external force is needed to break the cycle of interdependence. Concerted "technology-push" efforts by equipment manufacturers, or demands of city cable authorities, might provide such a force.

Another barrier to achieving the critical mass necessary is the high cost of wiring the city center. It is the area of highest data communication activity but also the most expensive area to wire. The high cost is due to the density of buildings and the lack of empty pole space. This forces the cable installer to tear up the streets in order to install underground cable. In



addition to the cost of wiring the city streets, there is the cost of wiring the buildings in the downtown sectors. High speed data communications is not of much use to a corporate headquarters if the data stream must trickle through the narrow bandwidth of telephone lines once it reaches the building. Therefore, for full utilization, the buildings must also be wired. Thus, effective corporate use of cable must await wider use of LANs. These problems are diminished in the more recently franchised cities where institutional network requirements are included in the franchise contract.

The availability of data communications services hinges on the installation of the proper cable plant. If cable operators, and their financing institutions were confident in the existence of a market and attractive revenues, the cable and other necessary facilities would be installed. One method for assuring the market is through joint ventures with interested high volume users such as banks and airlines. In addition to providing a customer base, these joint ventures could contribute to intelligent user-driven design of facilities and out-front financing.

In addition to physically appropriate facilities, higher level communication protocols must be implemented and standardized in order for communication based services to develop. Terminal manufacturers, information providers, cable operators, and users must all participate in this process for it to be truly affective; a difficult if not impossible task.

Even if joint ventures are not coordinated, it is likely that many of the major cities will be wired as part of residential cable franchising agreements. Increasing numbers of cities are requiring the installation of an institutional network in their downtown centers for government and commercial sector use. Some of these systems are being controlled separately from the residential network<sup>44</sup> Although local franchise agreements will insure that the institutional cable will be installed, if a market for these services is not visible, the system might remain unactivated. A final obstacle to development of the market, is that national service operators will be faced with providing service on multiple cable plants which vary significantly from one another in quality of transmission, and headend capability. This will place significant importance on media-transparent service system design, i.e., transaction services will have to operate over telephone, two-way cable, and hybrid networks.

---

<sup>44</sup> In New Orleans the institutional cable is being run by a separate subsidiary of the cable operator (COX Cable). In Tucson, the institutional cable will be owned by the municipality.

## 3.2 Service Structure Options

The service structure options for offering data communications via cable must be evaluated in terms of the two primary markets:

### - Residential Systems

- \* Banking, transaction, and information retrieval services, requiring communication between subscribers and commercial servers.
- \* Subscriber-to-subscriber communications for mail, messaging, and games.
- \* Home-to-office communications for professionals working at home.

### - Institutional Systems

- \* High speed data communications between commercial and institutional users -- inter-corporate and intra-corporate.
- \* High speed data communication connections to long-haul packet network services.
- \* Subscriber-to-subscriber communications for mail, messaging, facsimile, and resource sharing.

Each service structure implies a different set of requirements for the communication architecture of the cable system, the physical engineering of the cable network as well as the higher level protocols used. The architecture determines who can initiate communications, who controls the establishment of communication circuits, who can be uniquely addressed, and how much communication capacity is available to different classes of users.

### 3.2.1 Conventional Residential Systems -- Headend to Subscriber

Conventional cable networks which distribute video entertainment have simple and limited communications structures. Conventional systems share the common feature that all communications are either originated, or are addressed, to the headend.

#### 3.2.1.1 One-way Systems

In the simplest one-way systems, the headend transmits signals to all points on the network indiscriminately. Tiered services equip the individual user interfaces with varying access

privileges, typically according to the monthly service-fee paid by the user. Transmissions are still distributed to all points on the network from the headend, indiscriminately, but only some nodes are able to receive or descramble the signals.

A one-way information service, such as *teletext* can also be operated using a strictly one-way, headend to subscriber service structure. Unlike over-the-air teletext which uses only the vertical blanking interval (VBI) in the broadcast signal, cable systems have the option of allocating an entire channel to teletext information. For this application the subscriber is equipped with a page-grabber, and a keypad for selecting teletext pages. However, no information is sent back to the headend or the information provider.

### **3.2.1.2 Two-way Systems**

Conventional two-way systems allow for some information to flow from the subscriber nodes to the headend. This capability is most widely used for security and fire-alarm monitoring, or for pay-per-view television requests and billing. Both of these services not only require limited up-stream communications, but unique addressability as well.

A simple, polling, access scheme is typically used for these services. For monitoring and security systems, there need only be three message states -- alarm unactivated, alarm activated, and device inoperative. Pay-per-view television services require enough message states to communicate the identity of the channel or program being viewed to the headend; the headend responds by logging the request of the subscriber for billing purposes. In the case of alarm systems, the headend responds to any "alarm activated" or "alarm inoperative" message by signalling the local police and fire department, or cable repairman, respectively. Thus additional communications is required between the headend and the point of final message destination.

Conventional two-way systems can also be used for simple *videotex* services which:

- Require limited upstream data.
- Access information which is located typically at the headend.
- Can tolerate long response times typically associated with polling access schemes.

**The specification that all subscriber requests are serviced by the headend is the fundamental limitation of the conventional headend to subscriber communications structure.**

### **3.2.2 Multiple Server Residential Networks**

Not all transaction and information-retrieval applications can be appropriately served by a single server structure such as that described above. For example, banks, as primary participants in the growing transaction services industry, will be unlikely to hand over control of such services, let alone access to sensitive financial data, to the cable operator. They will require *server status* on the cable network, whereby they can control communications with subscribers directly. A second example is of a local printing service. High-quality printers are similar to photocopiers in that they are high, fixed-cost items that are used intermittently but that must be easily accessible. Therefore, as with photocopiers, the local, dry-cleaning or local drug store might offer a printing service at locations other than the headend; they too would require *server status*. Broadband technology requires that all signals pass through the headend. The difference between the multiple and single server structures is that *initiation, interpretation, and processing of the communications is allowed at points other than the headend*. This configuration has profound *institutional and technical* implications.

#### **3.2.2.1 Institutional requirements**

The cable operator must agree to operate, to some degree, as a "communications" service, and not a programming or information service. That is, the cable operator will provide transmission, network maintenance, and switching, but will not be involved in the content aspects of these interactive sessions.<sup>45</sup>

Having all communications processed through the headend gives extensive control of service implementation and quality to the cable operator. This is likely to raise concerns on the part of other service providers and subscribers, with respect to:

- The proprietary nature of the data being exchanged, the inability of the service provider to control the quality of the user-interface; and
- The implications of competitive services offered by the cable operator in addition to other service providers.

---

<sup>45</sup> At the same time, the operator might act as an information provider itself on other channels.

Privacy concerns are not inherent or unique to the communication structure. End-to-end encryption will be required to insure security of some data, both proprietary and private, on any cable communication system. Authentication of the message source will also be required in some applications. Both authentication and key distribution are examples of enhanced services that might be offered by service providers other than the cable operator.

The success of transaction services will depend on the quality of the user interface. Therefore, service providers will want direct control over the relevant aspects of subscriber communications. The particular application determines the sensitivity of the service to the quality of data communications on the cable network -- signal to noise ratios, traffic delays, bit error rate, etc. For instance, an electronic funds transfer (EFT) service for banks will be more sensitive to bit error rates than will an electronic game service. Similarly, a highly interactive service will be more sensitive to traffic delays than will a batch service. To the extent that the cable operator offers services that are equally sensitive, service providers other than the cable operator will have access to adequate transmission services; service providers with more sensitive applications will have to convince the operator that demand is high enough to warrant investment in higher quality transmission facilities. However, in order to have true control over the quality of the user interface, the service providers, and not the cable operator, may wish to control such application level features as response time, screen format, error-handling, and query format.

It is likely that if the cable operator and other service providers are competing for the same subscribers, the operator will have access to information and control which could provide anti-competitive advantages. The potential for abuse is high if the cable operator controls the user interface for competing services (see section 5.3.5). For instance, services that use high-resolution graphics can be very annoying to use if the data rate is so low that the user must wait for the screen to be "painted"; in such cases it is preferable to use lesser quality graphics. Therefore, transaction and information service providers are dependent upon the operator to implement their services at satisfactory speeds.

### 3.2.2.2 Technical requirements

The technical requirements for multiple-server communications include:

- A high bandwidth link between the server and the headend to take advantage of the high bandwidth downstream link to subscribers.

- The capability to address directly multiple servers, or the ability of the headend to respond to requests for communication links between subscribers and server nodes, i.e., complete logical connectivity between all nodes.

On conventional two-way systems, the vast majority of data travels from the headend to subscribers. This is consistent with the large amount of bandwidth that is available on the downstream path, compared to the small amount of upstream capacity. Server nodes that operate independently of the headend will require significantly more upstream capacity to transmit data to the headend for translation onto down-stream frequencies<sup>46</sup>. Residential subsplit systems will accommodate only a limited number of server nodes in addition to the headend. The number will depend on the volume of information and number of subscribers.

Most experimental videotex systems to date transmit all data via telephone lines. In these experimental systems information and software frequently called upon by subscribers is stored at the headend. This is largely due to the bottleneck created by narrowband local, or long haul, lines which connect the servers to the headend. If a server attempted to interact with subscribers in a "pass through"<sup>47</sup> manner, it would be greatly constrained by this phone line bottleneck, particularly in the case of multiple simultaneous requests. If the type and amount of information which is to be sent by these videotex and transaction services does require a high bandwidth medium, and if storage of frequently used information at the headend is not acceptable to the service providers, then a more appropriate configuration is to allow local servers to communicate with the headend and subscribers via upstream cable channels, or other high bandwidth media. Alternative technologies such as point-to-point microwave, DTS, leased telephone lines, are also possibilities for the transmission of the data between the servers and the headend; downstream data originated by the server, as well as upstream data addressed to the server by subscribers. If the communication services are to be used for communications among multiple computers, as opposed to between a terminal and a computer, high bandwidth channels will be needed in both directions.

Network nodes must be able to address each other and control communications with one

---

<sup>46</sup>The translation process is strictly a data communications task on the part of the operator, and is fundamentally different from the control possible in previously described configurations.

<sup>47</sup>Pass through refers to a passive transportation of information through the headend, with no processing, or active participation, other than the maintenance of a "virtual" connection between the subscriber and server.

another in a dynamic fashion. This capability requires that the headend be equipped with a computer and software that is significantly more complex than that needed for a simple polling scheme. In addition, the interface units of both server and subscriber nodes must be equipped with sufficient electronics and program control to implement the appropriate access scheme or switching method.

The connectivity and efficient bandwidth allocation offered by contention and DA-TDMA schemes are necessary and economically practical when services involve significant communication in both directions and between many parties. Therefore, these are the preferred access schemes. The current cost of these schemes may be prohibitive to use in residential networks. This will change but in the interim other, less suited, access schemes will also be implemented.

Switched FDM or TDM/TDMA services are not well suited to "bursty" traffic, since the bandwidth is dedicated, as opposed to dynamically allocated. Therefore, although they provide the connectivity, they are inappropriate for multipoint subscriber-to-server communications, where there are thousands of "bursty" residential nodes.

Of the access schemes discussed, polling is least suited to fast response, interactive, any-to-any communications. Nevertheless, on many residential networks, equipment availability, limited cable operator expertise, and interface unit cost will result in an attempt to use polling for such applications. One method for implementing any-to-any communication services using polling is described here to illustrate the difficulties. The headend polls subscribers for packets and forwards each packet to the addressed server (via the cable network or other established communications media). Servers similarly address all packets to particular subscribers and the headend translates these packets onto the appropriate downstream channel. In the case of a continuing interactive session the headend might set up a *virtual circuit* between the server and subscriber engaged. Upon request of a session, packets are automatically routed between the two until the session is completed. Throughput and response time are critical in interactive communications, and are very sensitive to the type of polling scheme used. Therefore, differential polling techniques can be used which adjust the polling frequency according to the status of each device; for example, all devices are polled once every minute, devices that have been active within the preceding minute are polled ten times per minute, and devices which have been active within the preceding tenth of a minute

are polled every one hundredth of a minute. In this way, faster response is directed to those devices engaged in interactive sessions. The downstream channel operates in a broadcast mode, where all subscribers listen to a common frequency band for their communications, but only the addressed device actually reads the contents of the communication. Although technically possible, polling schemes are not optimally suited to highly-interactive, fast-response communications among multiple servers.

### 3.2.3 Hybrid Residential Networks

One method of achieving the switched multipoint two-way communications capacity required is to use the telephone network as the upstream link. This method has been proposed by AT&T as a means of delivering videotex and transaction services.<sup>48</sup> The subscriber uses a modem and the standard telephone lines to communicate requests and information to the server. The server then transmits the addressed data or reply to the cable headend, via leased lines, and the headend sends it to the subscriber on the appropriate downstream frequency.<sup>49</sup>

The advantage of a hybrid system over a strictly telephone-based videotex system, is the higher bandwidth available for downstream communications. High resolution graphics take a long time to transmit over the narrow bandwidths available on telephone links. The advantage of the hybrid over a two-way cable system, is the existence of the telephone as a ubiquitous, addressable, upstream medium which avoids the cost of retrofitting one-way cable systems. Hybrid systems do entail the inherent disadvantages of coordinating the organizational, pricing, and technical operations between the telephone and cable companies, in addition to tying-up of phone facilities for voice communications; in particular, the resident is unable to place or receive phone calls, and the telephone exchange experiences longer holding times (see section 4 further discussion of data communications via telephone lines).

Their success is largely dependent on the relative attractiveness of interactive services that AT&T will offer subscribers, as compared to those which cable operators could offer. AT&T

---

<sup>48</sup> Seminar given by Dennis Sullivan, VP, Residential Marketing, AT&T, Harvard Program on Information Policy University, October, 1981.

<sup>49</sup> Hybrid networks are also suited to single-server networks where the subscriber sends requests to the headend via the telephone, and receives data on the downstream channel.



has technical, capital, and institutional resources to draw together a highly attractive service package. The cable operator desires the most attractive package in order to attract subscribers to cable. It is possible that the increased number of subscribers, and resulting revenue might be significantly higher than the revenue lost from subscriber fees for cable provided information services. In addition, much of the subscriber terminal development would be left to the telephone company which has the ability and capital to develop the technology with the proper economies of scale. Use of telephone lines for upstream transmission would also allow cable operators to meet some franchise agreement schedules for two-way services.

#### **3.2.4 Institutional Service -- Point-to-Point and Multipoint**

Unlike residential networks, institutional cable networks will initially be used in place of leased telephone lines for point-to-point applications such as large file transfers between the office of a multibranch company, or as a means of accessing specialized common carriers. Many cable operators will benefit from the "data communications experience" of this basic point-to-point service, before developing more sophisticated multipoint networking services.

Advanced data services are best served by a switched multipoint network. Data networks using cable technology in a switched multipoint configuration are currently in operation in industrial plants and research campuses for communication within and between buildings. These methods could be applied in the institutional market over the next five years. One example is the communication network needed to interconnect automated teller machines and bank branches. *Increasing dependence on high speed communications within corporate offices will increase intra-urban communications requirements.*

### **3.3 Costs**

Cable is a high-fixed-cost, low-variable-cost industry. Cable must be laid and programming acquired independent of the costs per number of subscribers. The principal variable cost is the interface unit. In the case of data communications services, these units are significantly more expensive than simple converters. In addition, the headend facilities for data communications add fixed cost and complexity. Data communications will sharply increase labor requirements for servicing and maintenance of both CPE and the cable plant.

In this section we examine cost estimates for cable-based services. Cost estimates are derived from recent cable franchise proposals [43], [20], NCTA statistics, and research conducted by M. Akgun, Government of Canada, Department of Communications [3]<sup>50</sup>.

### 3.3.1 Basic cable System Costs

The cost of traditional video distribution cable networks consists of the following: headend, CPE, cable distribution plant installation, operations and maintenance, and programming fees.

The headend for a simple "community antenna" costs approximately \$105,000 dollars. This number includes the cost of the antenna for reception of over-the-air signals. Satellite earth stations are an additional \$95,000 for two. The cost of the headend per home passed is from \$15 to \$25, assuming that penetration grows from 25% in the first year to 45% in the fifth year<sup>51</sup>. CPE for basic cable systems consist of television converters which are low cost items in the range of \$50 to \$80. The installation cost associated with bringing service into a customers home, is from \$40 to \$50 [13].

Table 3-1 illustrates typical 1981 prices for cable, distribution-plant, hardware components<sup>52</sup>, [37].

Cabling costs vary depending on the density of the area being wired. Urban centers are very expensive, whereas rural and suburban areas are not. Aerial installation costs range from \$7,500 to \$15,000 per mile (\$75 to \$150 per subscriber), \$2,500 to \$5,000 per mile are labor costs. If there is not enough capacity in existing ducts or aerial poles, the cable company must dig up the streets to install cable underground. This raises the cost of underground installation to anywhere between \$15,000 and \$100,000 per mile. The average cost of the cable plant installation per home passed ranges from \$75 to \$200 [46]. The total cost per

---

<sup>50</sup>We will assume a penetration rate of approximately 100 subscribers per mile for the sake of cost comparison. This figure is suggested by the NCTA as representative of non-rural areas and is comparable with the 110 subscribers per mile figure used by Akgun.

<sup>51</sup>These estimates of headend cost, per home passed, are larger than those given in Tables 3-2 and 3-3 because in the tables the cost of studio facilities for video programming is listed separately.

<sup>52</sup>Roberts, L., Karp, P., "Comparison of transmission media for Local Area Communication Networks". Paper in preparation, available from P. Karp, Amdax Corp., Irvine, California.

**Table 3-1: Distribution plant component prices (1981)**

Coaxial cable	\$	0.35/foot
Drop cable		0.31/foot
Amplifier		1,600.00
Power supply (amplifier)		400.00
Tap for power		30.00
4 port tap		16.00
8 port tap		35.00
Bridge tap		36.00
Splitter (2-way)		37.00
Splitter (3-way)		44.00
1/2" connector		3.00
1/4" connector		.50
1/2" terminator		3.50
1/4" terminator		.50
4 Port interface unit		4,000.00

home passed by cable therefore ranges from \$175 to \$300; given a 50% penetration rate, the cost is \$350 to \$700 per subscriber.

The operating expenses of cable systems are similar in most respects to other businesses. Unique expenses include copyright fees, pole rental fees, microwave expenses, and fees for programming and premium television. The operating expenses for large metropolitan systems are from 50% to 65% of revenues. Rural systems have lower operating costs of 45% to 55% of revenues. These expenses consist primarily of technical maintenance staff. The NCTA suggests the following average maintenance costs;

- Headend maintenance and repair: \$3,000 per year.
- System maintenance: \$75.00 per mile.

Programming costs for new systems in large metropolitan and suburban areas are estimated as high as \$1 million in the first year. The operator pays in the neighborhood of \$50 per year, per subscriber for pay-television services such as HBO, Showtime and Galavision.

Local programming expenses vary considerably depending on the franchise agreement.

Some recent franchises include entire staffs for local origination, while others include none. Net of advertising revenues, the NCTA cites local programming expenses at \$2,500 per year<sup>53</sup>

### 3.3.2 Two-way Residential System Costs

Two-way residential data communications will entail the following additional costs beyond the basic costs described above: an upgraded headend, more sophisticated CPE, retrofitting of existing one-way cable plant<sup>54</sup>, addition of appropriate equipment to compensate for upstream noise, and increased maintenance and service requirements.

At the end of this section we present a table of cost approximations for three hypothetical residential systems of increasing sophistication (see Table 3-2).

#### 3.3.2.1 Headend and Customer Premises Equipment

The cost of an upgraded headend includes the cost of the hardware and software required to implement the on-line services, e.g., billing, transaction services, data base storage and management, addressing, network management, and off network gateway services. Therefore, the cost will vary depending on the capabilities desired. Although the costs of a sophisticated headend for a large system can reach a few million dollars, it is still relatively small compared to the hundred million dollar total system installation cost. A 1978 study by the Department of Communications in Canada suggested the following numbers for headend costs for systems serving up to 100,000 subscribers:

- \$160,000 -- Teletext
- \$325,000 -- interactive polling.
- \$600,000 -- digital switching functions.
- \$950,000 -- packet switching functions.

<sup>53</sup>This number is very low possibly as a result of averaging together systems with and without local programming facilities.

<sup>54</sup>If the system is being newly installed, as opposed to retrofitted, the retrofitting costs do not apply.

The headend used in the Cox Cable videotex system, Indax, will cost \$2.8 million [20] (assuming the system accommodates 50,000 subscribers, the cost is \$56.00 per subscriber). The headend for the Warner Amex Milwaukee system will cost \$1.1 million [43] (assuming the system accommodates 50,000 subscribers, the cost is \$22.00 per subscriber). This difference, \$17 per subscriber, for the most part reflects the expense of implementing Cox's higher speed (0.028 Mbps, see section A.2.1.2), broader capability information and communication services, relative to Warner Amex's polled transaction services which are rather limited and inflexible (see section A.2.1.1). Both system headends are more than ten times the cost of a basic one-way cable television network, \$105,000 (see Table 3-2).

Cox Cable's two-way residential interface units, which use a 0.028 Mbps (0.223 bits/hz) contention protocol, will cost between \$200 and \$250<sup>55</sup>. For comparison, Warner Amex estimates approximately \$100 per subscriber for a simple polling unit and an average set-top converter for video reception costs approximately \$50.

The cost of FDM interface units vary according to modem speed and are typically upwards of \$500 a piece. DA-TDMA units run as high as \$4000 in current production quantities. Because of these higher costs FDM and DA-TDMA access schemes are only considered feasible for institutional systems at this time. These numbers are more a reflection of the perceived elasticity of subscriber demand than of the equipment costs. Interface unit costs for moderate to high speed data rates will remain high until they are manufactured in much larger quantities. Amdax Inc. manufactures both FDM and TDMA cable interface units for data communications. The rf-modem portion of the interface unit currently costs from \$200 to \$300 for a 0.128 Mbps modem, manufactured in quantities of 1,000. This cost is expected to drop in half if manufactured in quantities of 10,000<sup>56</sup>. The cost of the logic necessary to implement the communication protocol will drop as LSI and VLSI costs drop; but, rf components are currently difficult to implement in LSI.

---

<sup>55</sup>This cost estimate assumes significant production increases, and related economies of scale. Cox estimates a total cost of \$33,871,000 for all feeder cables, converters, and CPE, in its New Orleans network [20].

<sup>56</sup>Zak Kong, Director of Research, Amdax Corp, personal communication

### 3.3.2.2 Cable Plant

Cox Cable estimates distribution plant installation costs of over \$15,900 per mile (\$159 per subscriber) for the New Orleans Indax system. Warner Amex estimates that it would cost over \$15,000 per mile of aerial cable, and over \$26,000 per mile of underground cable installation in Milwaukee. Included in this cost are the cable plant components, namely amplifiers and bridge amplifiers, are installed at a frequency of .6 per mile, and cost \$1500 each (\$9.00 per subscriber, per mile). The majority of the cable installation costs are labor related.

These costs refer to construction of new cable systems. The cost associated with upgrading existing systems, to allow for two-way services, is also relevant for analyzing the comparative economics of using cable systems for data communication services. Retrofitting of two-way ready systems to two-way active systems involves insertion of upstream amplifier modules into all amplifier boxes. These modules cost in the neighborhood of \$100. A 1978 Cablesystems Engineering Ltd. study<sup>57</sup> estimated the total average cost of retrofitting a mile of cable to be \$783, for densities of 110 households per mile (\$7.57 per subscriber). Retrofitting of older systems which are not two-way ready could approach the cost of installing a new system<sup>58</sup>. These older systems ordinarily require upgrading from 12-channel, to 30-channel capacity. The upgrading process involves replacement of all cable plant amplifiers and bridges. If the transmission performance of the upgraded system is sufficient, the amplifiers used to replace the 12-channel amplifiers can be two-way as well. One-way modification modules typically cost \$340 apiece, or \$204 per mile (\$2.04 per subscriber). It is estimated that the per mile cost for rebuilding a system is \$1300 (\$13.00 per subscriber) more than the cost of upgrading an existing system [55]. In many cases the transmission performance of these modified systems may not be adequate for two-way data communications and the resulting higher maintenance costs might outweigh the higher cost of rebuilding. Warner Amex estimates that when trouble calls reach a level of 10 per 100 subscribers, per month, it becomes economical to rebuild the system.

Corrective measures that control upstream noise levels are necessary for two-way data

---

<sup>57</sup>E.N. Chislett, et al, *Selectability of CATV Services*, Cablesystems Engineering, June 1978, Contract Report. Cited by M. Akgun [3].

<sup>58</sup>\$10,000 to \$15,000 a mile, since most of these older systems are in rural or suburban areas where the cabling costs are not as high

communications over existing cable plant and will contribute to the retrofitting costs. Bridger Switches cost approximately \$350, but are typically installed at the time of system installation. As proposed earlier, digital regenerators might be installed in noisy systems, in conjunction with bridger switches to clean upstream channels. The digital regenerator hardware potentially costs approximately \$70 apiece, but no one manufactures cable-ready examples. Digital regenerators are manufactured for use in telephone plant and require modification for use in cable plant; initially, this customization might raise the cost to as much as \$500 apiece.

### 3.3.2.3 Operation and maintenance

Service and maintenance costs for new cable systems will be significant relative to total system cost. This is due to the increasing size of the systems, and the sophistication of services being offered. Warner Amex estimated the following plant maintenance expenses for their proposed Milwaukee system:

- Salaries: One plant technician for every 2,400 subscribers; Six preventive maintenance technicians per every 1,000 plant miles. Total = \$220,000 for the first year<sup>59</sup>.
- Converter Maintenance: \$4.15 per converter (this number should significantly increase with increased sophistication of the interface units utilized). Warner Amex estimates that they receive an average of 2.5 trouble calls per month, per 100 subscribers.
- Pole and Conduit Rental: \$160 per mile (\$1.60 per subscriber) annually, and \$2,000 per mile (\$20.00 per subscriber) annually, respectively.

Software and service costs associated with offering videotex and other transaction services are largely unknown.

### 3.3.3 Two-way Institutional System Costs

The total installation<sup>60</sup> cost of an institutional system is comparable to that of a residential system. Higher per-mile cable installation charges are offset by the typically smaller geographical coverage of the institutional network.

---

<sup>59</sup>The particular numbers cited in this and other franchise proposals often reflect demands made by the local cable authority.

<sup>60</sup>Retrofitting is not relevant since most existing institutional systems were recently built.

Institutional network headends are ordinarily lower in cost than residential headends because the system costs for the high speed communications services are off-loaded onto the CPE. Residential transaction and information services require that more control and software complexity reside in the headend. Institutional network headends are not equipped with antenna for over-the-air reception but may be equipped with a satellite dish for connection to long-haul facilities. Importantly, the elasticity of demand for data communication services in the institutional market is much lower than in the residential market. Therefore higher interface unit costs for higher speed services are tolerated.

The services and equipment costs offered on institutional networks most closely resemble those offered on private LACN networks. But, LACN headends are significantly less expensive than institutional, cable television, network headends. LACN headends act strictly as frequency translators, and do not have the facilities for reception of over-the-air signals. In addition, most LACN's do not implement information and transaction services at the headend. Therefore, they do not require a headend minicomputer and software of the same complexity and size. Amdax Inc. offers a single channel DA-TDMA system, Cablenet, with 0.056 Mbps user data rate and 14 Mbps aggregate data rate over two channels (1 bits/hz). The headend is specified to serve up to 4,000 user locations<sup>61</sup> and costs \$9,750 (\$2.18 per user location) [37]. Interface units, each with four ports, cost \$4000 apiece. In urban systems, the cost of the headend is likely to be increased, so as to offload the price from the subscribers as much as is possible. Sytek's LocalNet40 is a multiple channel contention LACN which runs at 2 Mbps (0.33 bits/hz) over 3 mile distances; the user data rate is 1 Mbps. Sytek's LocalNet20 accommodates over 100 128 Kbps contention channels over 10 mile distances; the user data rate is 0.019 Mbps [11]. The headend is specified to serve up to 100,000 users and costs \$3500 [50].

Digital Communication Corporation (DCC) offers CAPAC, a DA-TDMA system which provides user channels from 1200 bps (0.0012 Mbps) up to 1.544 Mbps (0.257 bits/hz) on a demand assignment basis. User node costs are on the order of \$8,000; a central node for an institutional cable system costs between \$50,000 and 75,000. These relatively high prices reflect the higher data rate offered, as well as DCC's position as the sole current supplier of equipment with these specifications. Table 3-2 gives estimates of broadband LACN system

---

<sup>61</sup> Each user location on the network accommodates up to four devices.



**Table 3-2: Broadband local area network vendor prices**

	<u>Amdax</u>	<u>DCC</u>	<u>Sytek</u> <sup>63</sup>	<u>Wang</u>
<u>Controller</u>				
2 Port		1,600	1,175	
4 Port	3,900	2,400		3,800
16 Port			4,200	
<u>Headend</u>	8,950		5,800	12,000
<u>Cost/node</u> <sup>64</sup>	984	800	268	952
<u>User data rate</u> 56 kbps		N/A	19.2 kbps	N/A

costs for intra-plant networks, as opposed to intra-city networks<sup>62</sup>.

To summarize our discussion of system costs we present below approximations of system-component costs for three residential cable systems of increasing sophistication (see Table 3-2). The residential systems are assumed to serve 50,000 subscribers, 100 subscribers per mile, with approximately 20% to 25% penetration of enhanced services. The institutional system is assumed to have 500 subscribers<sup>65</sup>.

The following table (see Table 3-3) contains rough estimates of the typical cost per subscriber for cable network facilities (capital costs) and system operation (operating costs).

<sup>63</sup> Sytek LocalNet20.

<sup>64</sup> Calculated for a 1,000-station system.

<sup>62</sup> Roberts, L., Karp, P. *Ibid.*

<sup>65</sup> Because there is only one institutional system in operation this number is not representative of any U.S. average.

**Table 3-3: Cost profiles of four systems**

<u>Components</u>	<u>Systems</u>			
	Two-way ready	Warner Amex	Cox	Institutional
Headend	\$150,000 \$3/sub	\$1,100,000 \$22/sub	\$2,800,000 \$58/sub	\$100,000 \$200/sub
CPE <sup>66</sup>	\$75/sub	\$100/sub	\$250/sub <sup>67</sup>	\$500-\$4000/sub
Cable	\$7,500 to \$100,000 per mile installed; \$7.50 to \$100 per subscriber. Actual cost depends upon amount of pole and underground duct space available. \$783 per mile of cable retrofitted from one-way to two-way; \$7.83 per subscriber.			

**Table 3-4: Typical cost per subscriber (assume: 50,000 subscribers, 100 subscribers/mile).**

<u>Capital Costs</u>	<u>Operating Costs/year</u>
Basic headend	Headend maintenance
Satellite receiver	Cable maintenance
Extra for interactive	Program material
Studio equipment	Premium material
Customer equipment	Pole rental
Extra for interactive	Administration
Installation	
Cable plant	
<b>Total</b>	<b>Total</b>

### 3.4 Prices

It is difficult to know what the tariff structures of two-way data services are likely to be. This brief discussion attempts to identify possibilities. Currently prices reflect the local monopoly status of the cable operator, or prices of the closest competitor, the telephone company. Cable operators do not maximize total revenue minus total cost (TR-TC). Rather, because

<sup>66</sup>Customer premises equipment.

<sup>67</sup>This estimate assumes large production volumes which are not yet in production.

currently there are excess channels, the value assigned to a channel is zero, and the cable operator maximizes total revenue minus marginal costs (TR-MC). This assumes that there are no opportunity costs in using a channel.

Current residential cable tariffs only reflect the charges to subscribers. Charges for interactive services follow a similar pricing structure: flat rate plus a per usage charge. Warner Amex proposed a \$29.95 installation charge and a \$4.95 monthly fee, for its 72 channel basic service. The so-called municipal service is \$45.00 installation charge, and no monthly fee. This service offers 12 channels of community programs, and access to home security (at an additional cost). The Warner Amex Qube service includes 14 channels of teletext, games, polled interactive services, etc.. There is a \$19.95 installation charge, with a \$4.95 monthly fee (note, there is no usage charge). Cox Cable's Indax proposed service tariffs in New Orleans are \$15 installation plus \$7.95 per month for Tier I and Tier II service, and \$98-200 installation plus \$15-\$19 per month for security monitoring systems.

The only existing precedent for institutional tariffs are those charged by Manhattan cable (MCTV), see Table 3-4. These tariffs were set primarily so as to be competitive with telephone leased line rates while maximizing revenues. It is likely that institutional service will continue to be priced in this manner, since the threat of entry of an alternative institutional service, due to high prices is minimal<sup>68,69</sup>. Installation charges are \$150 to \$200 per end, depending upon the data rate. The Cox tariff is proposed for the New Orleans Institutional cable. Institutional interface units are in the \$1000 range.

In addition to subscriber tariffs, future two-way services will include tariffs charged to other service providers. The only analogous service on video systems is *leased access*, in which the cable operator leases a video channel to another programmer. Typically leased access has applied to community groups at nominal or zero charge, which does not reflect what would be charged to commercial parties. In addition, this form of leased access referred only to downstream transmission. There is little precedent on which to base estimates of the tariffs that would be charged to servers, by the cable operator, for a "communication service".

---

<sup>68</sup> It is possible that with the introduction of DTS services this situation will change, and institutional service rates will be forced closer to marginal cost.

<sup>69</sup> MCTV, Manhattan Cable Communication System, Monthly Lease Rates, June 1, 1980.

**Table 3-5: MCTV monthly lease rates, June 1990**

Bit rate <sup>70</sup>	Cox Cable	MCTV
1200 bps	\$37/month	\$145/month
2400 bps	\$55/month	\$160/month
4800 bps	\$119/month	\$200/month <sup>71</sup>
9600 bps	\$230/month	\$300/month
19.2 kbps	\$500/month	\$420/month (synch)
56 kbps	\$1000/month	\$475/month (synch)
1.54 Mbps	\$1000/month	\$1000/month (synch)

Service structures in which the headend is the only server would not entail a "communications" charge to other parties. Instead, arrangements between information service providers, such as banks, CompuServe, or Lexis, would initially be established on a case by case basis.

Eventually, both servers and subscribers, are likely to be charged on a usage sensitive basis. Only in the case of dedicated channels, or extremely light usage will flat rates remain in use. This need for usage sensitive pricing is due to the increasing marginal cost of most systems, i.e. performance degrades with heavy usage. The reason that it will not occur immediately, is that until the communications facilities are minimally loaded, marginal cost is not increasing, and therefore the cost of monitoring usage is not justified. DA-TDMA and contention schemes in particular can suffer from abusive overuse of the flat rate services because of the degradation in service that is experienced with severe overloading.

Cable network fees are likely to be insensitive to mileage, since all communications is local. Communications which travel off of the cable network will be charged according to the costs of the communication facilities over which they travel, i.e., this cost will be passed through to the user.

<sup>70</sup> Bit rate per 6 Mhz channel.

<sup>71</sup> This compares to a cost of \$400/month, including interface unit rental for a leased voice grade line.

Many institutions are strongly adverse to having AT&T rate structures remain as the model for communications pricing. In fact an alternative to AT&T pricing methods could be the primary attraction of business users to cable usage, beyond the availability of higher speed and quality services. Other technologies with which cable will be competing will face the same challenge. Major users in New York face a 40% increase in their communications costs over the next year. Users are anxious to protect themselves from these rate increases.

### 3.5 Summary

Networks that will support future services must accommodate communication with multiple servers. The costs incurred, above and beyond the costs associated with traditional networks, are concentrated in the headend, interface equipment, maintenance, and where necessary cable plant upgrade and noise correction measures. The sophistication of the services provided will most significantly affect the cost of the interface equipment. Prices of existing services bear little relation to costs. Charges for institutional services for the most part reflect the prices charged for competing services offered by the telephone company. Residential charges, for those services that are in operation, are tier-structured. Rate-levels are difficult to predict, pending more data on demand elasticities.

We have presented our analysis of cable as a data transmission medium, including technical complications and remedies. We have also discussed the implementation decisions associated with higher level communication protocols, in particular access schemes. In the next chapter we compare the anticipated performance of cable television systems with services proposed by the phone company and other special carriers for the 1982 to 1985 timeframe.

## Chapter Four

# Alternative media: telephone local loop and Digital Termination Services

In this chapter we describe two alternative transmission media for residential and institutional regional data communications: the telephone local loop and Digital Termination Service (DTS). We find that these media will compete with two-way cable television for the residential and institutional data communication markets, but that cable television technology is superior to both the telephone plant and DTS in many respects.

### 4.1 Telephone local loop

Although the public switched telephone network is reliable and supports up to 2400 bps two-way (full-duplex) communications, or 4800 bps half-duplex, it is engineered and tarified for voice traffic. Several characteristics of the PSTN make it not well suited for data traffic:

- Analog transmission requires conversion of digital data signals. The particular historically developed constraints of the voice channel, with forbidden frequencies, uncontrolled phase delays, etc., complicates the conversion and makes it relatively expensive.
- The statistics of data differ with those of voice. The long connection times experienced between terminals and computers, are disruptive to the operation of telephone company switches which are configured with a suitable number of trunks for a 3 minute average connection time (holding time). On the other hand, for computer-to-computer connections over which only seconds worth of data need be sent, the call set-up time and minimum 3 minute charge is too long and the call set-up components in the switch are over-used.
- The dedicated circuit provided for the course of a connection is inefficient for data traffic which tends to be in high intensity bursts. During transmission of a burst, the data source and sink can generate and receive data at a much greater rate than the bandwidth of the twisted pair. Between bursts, the line is idle. Smoothing the traffic by buffering the data is acceptable for some applications; for others, the delay incurred by buffering makes the application inefficient.

The use of voice facilities for data traffic leads to high access cost and contention with normal voice service, in addition to suboptimal transmission characteristics. The telephone company or the user experiences excessive line termination, modem, and port costs.

Modems are used to transmit digital signals over analog voice lines. Modems can transmit up to 9600 bps over conditioned leased telephone lines. 4800 bps can be achieved over unconditioned lines. Modems can be leased from the telephone company or purchased by the subscriber independently (so long as they are FCC approved).

AT&T's Digital Data Service (DDS) eliminates the need for modems by supplying digital links, at speeds up to 56 Kbps, directly to the subscriber. In addition, line error rates are superior to those of most voice-grade lines. The service is offered in a limited number of cities, at relatively high monthly rates. The monthly rate for a 2.4 Kbps DDS line, within a city center, is approximately \$250, while a standard, analog, leased line, within a city center, is only \$100 per month. Monthly rates for 56 Kbps DDS lines are in the \$650 to \$700 range.

The advantages of end-to-end digital transmission services for data communications are clear; but, the majority of telephone network traffic is voice. Using existing digitizing technology, the transmission of digitized voice requires more bandwidth than does transmission of analog voice. Nevertheless, the cost of the components used in digital switches is dropping so rapidly relative to the cost of analog switch components that the overall economics makes it increasingly worthwhile to use digital transmission for voice services too; this contributes to the trend towards an all digital network.

The largest remaining bottleneck in end-to-end digital service is the local loop. The following section will describe two communications technologies, which have been described by the telephone company in the technical literature, for digital transmission over the existing local loop facilities. In addition to the technical details, we hope to identify the cost, maintenance, and implementation difficulties which will impact the attractiveness of these services relative to cable television based services.

#### **4.1.1 Circuit-Switched, Digital Capability**

*Circuit-switched, digital capability (CSDC)* refers to a 56 Kbps, alternate voice/data circuit-switched capability (see Figure 4-0) [2]. Customers will dial a call using ordinary touch tone

facilities. When the call is set up they will be able to signal the switch to allow transmission of 56 Kbps digital data. They will be able to switch back and forth between transmitting analog voice and transmitting digital data at any time during the call.

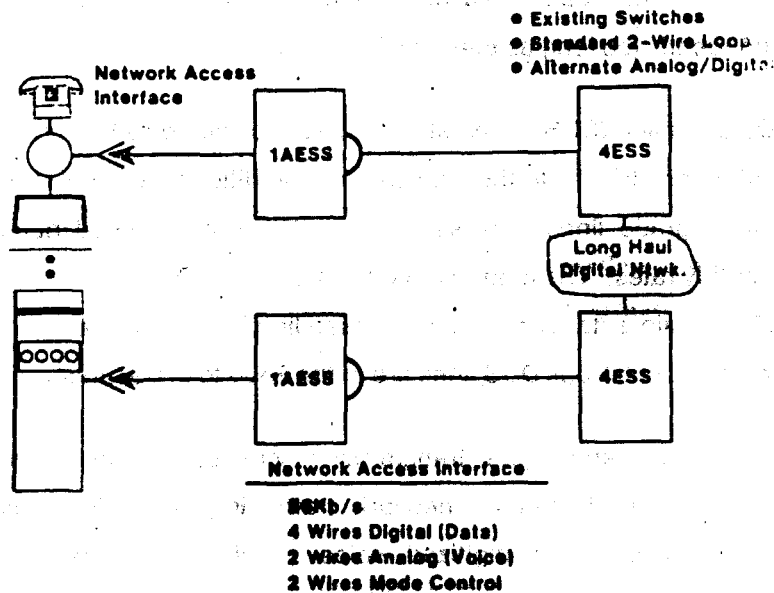

Figure 4-1: Circuit Switched Digital Capability (N. Long, Bell Laboratories<sup>72</sup>).

A new transmission technology, *time compression multiplexing (TCM)* [2], allows full duplex 56 Kbps digital transmission using the existing two-wire subscriber loops. Switching is achieved via minimally modified telephone company local switches and unmodified toll switches<sup>73</sup>. The expected market for this capability is institutional users for applications such as high speed facsimile, bulk data transfers, and other computer to computer communications. The CSDC architecture is very similar to that of existing voice service facilities, therefore few difficulties are foreseen in its development and maintenance.

<sup>72</sup>This figure was provided by N. Long of Bell Laboratories at a seminar entitled *New technology and the local loop*; Communications Policy Research Program Seminar, M.I.T., Cambridge, Massachusetts, September 24, 1981.

<sup>73</sup>The modified local switch is the #1A ESS, and the toll switch is the #4 ESS. ESS stands for Electronic Switching System, and is a family of computer controlled telephone switches used by the Bell Telephone companies.



#### 4.1.1.1 Costs

One circuit termination line card is required, per subscriber, at the subscriber loop interface to the local switch, in addition to the circuit termination card at each customer's premises. Each line card is estimated to initially cost \$600, or \$1200 per line connection<sup>74</sup>. This cost estimate is based on high volumes of production, i.e., quantities must be sufficient to justify production of a TCM chip:

The alternate voice/data channel unit is shared by multiple subscribers and is only in use during a data mode call. An average unit serving 10 subscribers is estimated to cost \$1000, yielding a relatively small cost per subscriber, \$100.

The cost of the software module, which will be amortized, should be in the range of \$10,000. This cost will be divided over the number of subscribers using the switch<sup>75</sup>.

The services will be offered by the local operating companies. Equal access rules that apply to standard telephone service will largely be applied to CSDC, i.e., interfaces to the local telephone companies' facilities will have to be made public and accommodate other long haul carriers.

#### 4.1.2 Data Above Voice (DAV) -- Local Area Data Transport (LADT) services

Local area data transport services are intended to provide residence and business customers with network interfaces through which they can access a packet switched network, primarily for communication with vendor data bases (see Figure 4-1). Applications include home or business, interactive, information systems; security; and energy management systems.

The service is designed to provide moderate speed (1.2 Kbps to 8 Kbps) data communications to "bursty" users in the home and small businesses. In addition, the data capability is designed so as not to contend with traditional voice services for the use of transmission

---

<sup>74</sup> Estimates are based on conversations with Dr. E. Claire of Harris Corporation and Roland Zalite of Bell-Northern Research, February, 1982. J. McDonald of MBX Inc., formerly of TRW-VIDAR, estimates that both the network/circuit termination equipment and the incoming line card to the switch should be as low as \$300 each.

<sup>75</sup> It is not clear exactly how the local telephone company will purchase the software; \$10,000 per switch, or \$10,000 for one version of the software which would then be copied for use on other local switches.

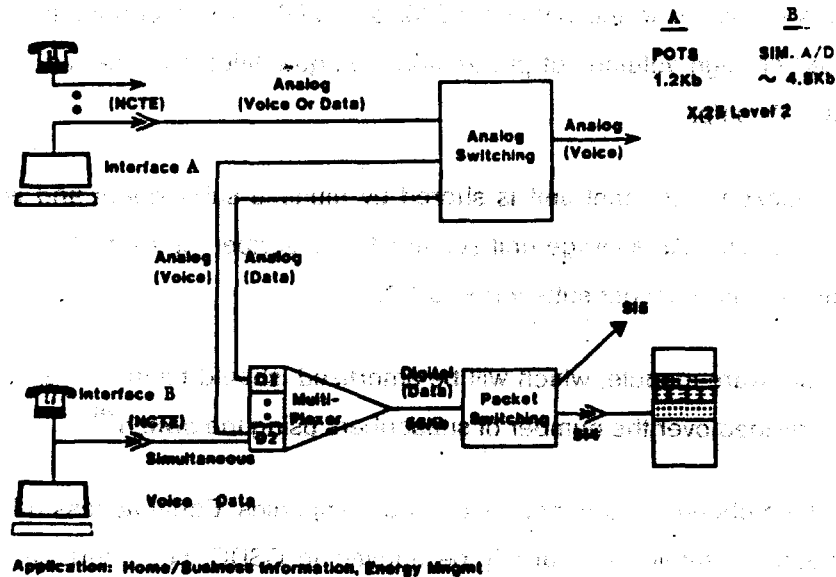

Figure 4-2: Local Area Data Transport Capability (N. Long, Bell Laboratories<sup>76</sup>).

facilities between the subscriber and the central exchange. Packet switched data transport facilities are most appropriate for these classes of users and applications.

The user will access LADT via the same wire pair used for voice telephone service. Data circuit equipment on the customer's premises and line interface cards at the central exchange will put the digital data signals in the frequency spectrum above the analog voice signals, a technology referred to as *Data Above Voice (DAV)*<sup>77</sup>. Using this technique, the data circuits will not contend with voice telephone usage (as does CSDD), but will operate simultaneously over the same twisted pair. The interface unit will have a data input port which will conform to international data communication standards<sup>78</sup>.

<sup>76</sup> *Ibid*

<sup>77</sup> Long, N., *Ibid*.

<sup>78</sup> CCITT communication standard X.25, level 1

The voice and data will be separated (filtered) and the voice will be passed on to the local switch. At the entrance to the local switch, the data signals will be connected to a port of a statistical multiplexor. All data signals will be concentrated and sent to a packet switch via 56 Kbps lines.

Infrequent users of LADT services may prefer to use a standard modem to make a data call, rather than pay the extra charges for DAV transmission capability. Subscriber access for the occasional user would be provided via a standard modem and the dial up network. When used in this manner, use of the facilities for data would preclude voice communications.

Unlike, CSDC, the packet architecture of DAV services offers new challenges to the phone company<sup>79</sup>. In addition the residential information and data market is bit yet developed. Therefore, near term offerings of these services are likely to be experimental.

#### 4.1.2.1 Costs

The data circuit equipment on the customer's premises and the entrance unit hardware required in the central office will cost between \$200 and \$400 installed<sup>80</sup>. If volumes are large enough to warrant the use of custom LSI, these costs would drop significantly<sup>81</sup>. The statistical multiplexor will present somewhat of a barrier in that it is a high fixed cost item. To justify it, there must be a critical mass of subscribers to LADT-based services in the same local area. Nevertheless, it should result in a fairly inexpensive per user cost.

Finally, the local operating company must install a packet switch to provide data switching for interfacing to multiple hosts and long haul networks. This installation represents a larger departure for the local telephone operating company, in terms of technology and fixed cost than does CSDC. Thus, LADT services will be introduced more slowly and in few cities at a time.

---

<sup>79</sup> Although other telephone-switch vendors already offer DAV capability (e.g., ROLM, BNR, etc.), these services have not been offered on a city-wide scale.

<sup>80</sup> Seiscor Division markets an Integrated Data Voice Carrier (IDVC) system offering similar capabilities at speeds up to 9.6 Kbps, over 3.6 mile runs, for \$534. New York Telephone is currently evaluating this product.

<sup>81</sup> Estimates are based on conversations with Dr. E. Claire of Harris Corporation and Roland Zalite of Bell-Northern Research, April 1982.

All facilities, including the packet switch will be owned by the local telephone company. Therefore, equal local facility access and interconnection will be provided to all long haul carriers and packet network services via a standard network-to-network interface. AT&T has already introduced proposals to the CCITT for new standards to govern DAV.

## 4.2 DTS

In 1981 the FCC approved a petition by the Xerox Corporation to allocate spectrum in the 10 Ghz band (10.55 - 10.68 Ghz) for a high speed, local, data communication service called Digital Termination Service (DTS)<sup>82</sup>. In the ensuing year, many specialized carriers have submitted requests for licenses<sup>83</sup>. DTS uses a fixed cellular radio technique whereby users communicate with one or more local nodes which in turn communicate with longhaul facilities. One or more nodal stations communicate with multiple user stations within a radius of up to 4 miles.

The user experiences data rates up to 1.544 Mbps. TDM is used to transmit from the nodal stations to the user stations, while users transmit back to nodal stations on a TDMA or TDMA-DA basis. Within 4.5 Mhz of bandwidth an aggregate data rate of 5.4 Mbps is achieved (1.2 bits/hz). The cost of a DTS system is currently quoted at \$11,500 per user station and \$117,000 per 120° central node sector<sup>84</sup>.

## 4.3 Comparison

Institutional cable networks will compete for the commercial data communications market with existing telephone services (DDS and leased lines), future telephone services (CSDC), and specialized carriers (DTS). Time will prove to be a determining factor in determining which of these services dominates any particular market.

---

<sup>82</sup> Xerox originally called the service XTEN.

<sup>83</sup> After observing the number of specialized carriers that offered to provide DTS, Xerox left the field to them.

<sup>84</sup> Digital Communications Corporation of Gaithersburg, Maryland is one of two suppliers of DTS equipment. GTE-Telenet estimates that installed costs are approximately \$113,000 and \$400,000, respectively.

At rates up to 56 Kbps, CSDC is an attractive alternative to institutional cable service. But, there is no reason to believe that market demand will stop at 56 Kbps. In those cities with moderate amounts of traffic, CSDC will be adequate. But, in those cities with large demands, or with installed institutional networks, cable services will find their place for rates greater than 56 Kbps. The competitive dynamic between cable and telephone services will be largely affected by the tariff structure of the telephone company. At the same time, the existence of a competing medium will force the telephone company's rates down.

DTS has the advantage of low construction costs relative to institutional cable; but, if the institutional cable is already installed, this advantage disappears. As was exemplified in the LDD-Tymnet-SBS experiment (see Section A.1.2.2), cable and DTS complement each other. Therefore, in those cities that have institutional cable networks, the advantage of DTS is unclear, unless it is used to complement the cable facilities. In those cities that do not have institutional networks, DTS is attractive on a cost basis. It will be many years before DTS equipment drops in cost low enough to be of interest in the residential market.

LADT is a very attractive alternative for the residential market. The total cost of upgrading the telephone local loop for DAV service is estimated to be somewhat less than that of upgrading a two-way ready cable system for comparable services<sup>85</sup>. For services less than 8 Kbps, the ubiquitousness of telephone facilities gives these services a tremendous advantage. In addition, the star configuration of the telephone network offers security and fraud advantages over a shared channel cable architecture, see Section 2.3.2.2. On the other hand, there is no telling how long it will take for these services to become widely available; and when they do become available, whether the peak data rate offered will be adequate. In the mean time, the development and availability of cable services could consume all of this apparent advantage. As in the institutional market, all three media, as well as others, will be a part of the communications backbone. The characteristics of the particular community and companies involved will determine the outcome.

Having presented and analyzed the technical characteristics of cable television networks as a data communications medium, in the following chapter we briefly review this information from the perspective of cable operators.

---

<sup>85</sup> Snowden, Personal telephone communications, February, 1982.

# Chapter Five

## Regulatory Issues

### 5.1 Introduction

The offering of data communication services by cable operators poses particularly interesting questions as to the proper regulatory structure for communication industries that both operate the communication conduit and sell services over it, whether pay television, videotex, or electronic mail. In this chapter we outline the policy context of data communications via cable and propose how the regulatory framework of cable television might be most suitably adapted to data communication applications.

Cable television networks offer peak communication data rates that are orders of magnitude greater than the telephone company's narrowband local loop. The "local loop", i.e. intracity communication facilities, is an important but weak link in the U.S. telecommunications network, as Charter et. al. note [18].

The availability of diverse communications services can provide powerful leverage for greatly enhancing the nation's information-based economy. The weak link now in providing advanced communications services to business and the public is at the local distribution level. The diversity of services possible through local distribution is being inhibited by traditional views on local distribution and prevailing regulatory policies.

*The use of cable television networks for data communications involves a technology and an industry, both of which already exist, but for wholly different applications. Cable has been used principally for home entertainment television signal transmission. But, given proper system design, it is equally appropriate for transmitting and receiving data to and from residences and businesses. Data over cable poses fundamental and compelling policy questions. Such questions include:*

- Is cable operation a broadcast or common carriage function? Is it both?
- Under which jurisdiction should cable fall -- local, state, federal?

- Should the operator of the network facilities have full control over the services provided over the network?

Cable is currently categorized as a broadcast service and is only minimally regulated by the federal government. Operators are granted franchises and given local monopolies by local governments which last typically fifteen years. In contrast, telephone and most other transmission services are regulated as common carriers by both state and federal governments. Common carrier regulation traditionally implies rate of return regulation and two fundamental behavioral stipulations:

1. Services are made available to everyone on a non-discriminatory basis, and
2. No control is exercised over the content of the communications.

The dichotomy set up in the Communications Act of 1934 treats common carriers and broadcasters quite differently. Broadcasters are given control both over their transmitters and the programs, or content, of their broadcasts. Indeed they are held accountable for the content through such means as the Fairness Doctrine and community service rules. In contrast the common carrier controls only the conduit, or transmission media, over which communication signals are carried, and is specifically prohibited from exerting any control over the content of those signals. The 1934 act granted the Federal Communications Commission (FCC) jurisdiction over both sectors, with a separate set of provisions for each. In addition, the act stated that services regulated under one set of provisions could not be subject to the other set as well. Until recently it was not difficult to determine which communication services belonged under which category. Today, just as the dichotomy between computing and communications has blurred as a result of technological developments, so has the demarcation between certain common carrier and broadcast technologies. Home and business information services are proposed which will deliver text and data via broadcast media which are traditionally used for entertainment video television. At the same time, broadcast two-way television services use data communications for polling subscribers.

## 5.2 Regulatory Jurisdiction

### 5.2.1 Background

In the 1969 *Southwestern* decision<sup>86</sup> the FCC's role in cable regulation was defined to include jurisdiction over all services which were "ancillary to broadcasting". The sole function of cable operators at that time was to rebroadcast over the air television signals and the Communications Act of 1934 had granted the FCC jurisdiction over all broadcasting<sup>87</sup>.

The FCC's 1972 *Cable Television Report and Order*<sup>88</sup> set forth federal constraints on cable. In addition to channel capacity requirements, the order included a two-way capacity requirement for all systems serving major markets. The requirement stated that each plant should have the "technical capacity for non-voice return communications", but did not require that the services be active. Although the FCC recognized that active two-way services were premature, the rationale behind such a regulation was to limit the costs for adding two-way capabilities in the future. In June of 1972 the FCC modified this regulation by restricting local franchise boards from requiring more stringent two-way requirements<sup>89</sup>. The FCC was afraid that some requirements imposed by local bodies would be beyond the state-of-the-art, and would prove prohibitive to the cable operators.

In 1975 the FCC opened an investigation into the viability of maintaining the two-way regulations<sup>90</sup>. The cable industry was eager to have the requirement removed. Because the market still showed no signs of producing revenues for the operators the extra cost of installing two-way systems was viewed as overly burdensome. The industry claimed that the extra cost was anywhere from 10 to 140 percent higher for two-way capacity systems that also satisfied the new channel capacity requirements. But the FCC maintained its position that the very high cost of rebuilding a one-way system warranted the relatively small additional cost

---

<sup>86</sup> *United States v. Southwestern Cable Co.*, 392 US 157, 1968.

<sup>87</sup> 1934 Communications Act, Section II.

<sup>88</sup> *Cable Television Report and Order*, 36 FCC 2d 143, 2 February 1972.

<sup>89</sup> *Reconsideration of Cable Television Report and Order*, 36 FCC 2d 326, 16 June 1972.

<sup>90</sup> *Notice of Proposed Rule Making in Docket 20508*, 53 FCC 2d 782, 784, 3 June, 1975.



incurred in building with two-way capability from the start. The FCC did limit the requirement to only those systems with 3500 or more subscribers, so as not to burden smaller, less profitable systems.

The Jurisdiction of the FCC was questioned under the N.A.R.U.C. decision<sup>91</sup> which concluded that two-way cable communications which were non-voice were not "ancillary to broadcasting", and therefore did not fall within the jurisdiction of FCC regulation of cable television established in *Southwestern*. In addition, they were within the intrastate restrictions of the Communications Act of 1934.

In 1978 the courts acted to severely limit the FCC's jurisdiction over cable by overruling the agency's authority to establish local access requirements<sup>92</sup>. The two-way requirements were also struck down. The basis for the decision was that these requirements burdened the cable operator with common carriage responsibilities. The communications act explicitly states that if a media is regulated as a broadcaster, that it must be exempted from common carrier regulation. Therefore, so long as the FCC chose to regulate cable "ancillary to broadcasting" (as stated in *Southwestern*) the FCC could not enforce the common carriage requirements. By this time, however, two-way capability had become a crucial element in the franchising process.

### 5.2.2 State and local regulation and federal preemption

The Congress and the FCC currently advocate increased deregulation of cable at the federal level. This leaves the states and municipalities to apply regulation as they see fit. In the past this responsibility rested with the municipal franchising bodies. But, as the influence of the federal government recedes, the state legislatures and public utility commissions (PUCs) are playing a larger role. So long as the cable systems remain intrastate, the emphasis on local and state regulation is in accord with jurisdictional precedent.

One foreseeable problem with State regulation of cable is the documented tendency of State

---

<sup>91</sup> *National Association of Regulatory Utility Commissioners (NARUC) v FCC*, 36 RR 2d 393, US Appeals District Court, 1976.

<sup>92</sup> *Midwest Video Corp. v. FCC, ACLU v. FCC*, US Court of Appeals for the Eighth Circuit, 21 February, 1978

governments to protect existing industries; in this case the local telephone company [42]. This could bias the state PUCs towards enforcing strict common carrier regulation for data over cable as a means of protecting the telephone company. But, should the state PUCs take action that is undesirable to the cable operators, the operators could respond by running their systems across state lines and thereby forcing themselves beyond state jurisdiction; assuming that the operators gain *rights of way* from neighboring states. Similarly, the FCC or Congress might react to seemingly unfavorable state regulation by preempting state jurisdiction if it can show that proposed state policy would disrupt national policies, i.e., inconsistent state regulations could prove a barrier to standardized nation-wide service, just as local regulations could prove a barrier to coordination of state-wide regulation.

The 1976 report of the Subcommittee on Communications of the Committee on Interstate and Foreign Commerce of the U.S. House of Representatives recommended that State regulation should be relied upon more heavily, with simultaneous lessening of local and Federal powers [19]:

The federal regulatory role should be confined to those aspects requiring national delineation of standards. Such areas should be defined, and where federal preemption is called for to avoid interference with federal objectives, the logic of preemption should be explicitly stated.

In their work on electronic publishing, Neustadt et. al. [47] propose three criteria for judging federal jurisdiction:

1. Is it ancillary to broadcasting?
2. Does it fall under the common carriage section, section 2, of the communications act?
3. Would non-federal regulation disrupt legitimate federal policy?

There are three areas in which the federal government might then preempt local and/or state regulation:

1. Content regulation.
2. Intrastate information services, i.e., data base access.
3. Intrastate transmission.

Preemption of content regulation provisions are likely on the basis of resulting First Amendment infringement. Similarly, under *Brookhaven*<sup>93</sup>, regulation of intrastate rates for information services might be preempted to promote diversity of content sources.

The most difficult case is that of intrastate transmission. Federal preemption was explicitly struck down in *NARUC II*<sup>94</sup> because too little evidence was put forward to show that local regulation would hinder legitimate national policy. The 1976 subcommittee report [19] stated that preemption of cable transmission regulation would be equivalent to the preemption of local telephone regulation and therefore it was not appropriate. One could argue that the federal government does restrict local operating companies from offering information services over their local loop facilities and therefore, federal regulation to assure some degree of separations or leased access on cable facilities is appropriate (See Section 5.3.5). In addition, use of cable for data communications increases the possibility that national policy will be disrupted if no federal coordination is allowed for. In light of the proposed consent decree between AT&T and the Department of Justice, the issue of access fees and the relative competitiveness of local operating companies is of increased importance<sup>95</sup>.

### 5.2.3 The Local Franchising Process

Cable operators apply to local governments for city franchises. A board or committee of the local government defines a set of criteria to be met by all applicants. These criteria are minimally determined by federal regulations, e.g., two-way ready capabilities, maximum franchise fees that can be required of the cable operator by the city, etc. The franchising process has become highly competitive, and requires significant resources on the part of the cable operators, particularly in the larger cities which promise large markets<sup>96</sup>. Competition has led prospective franchises increasingly to promise two-way services in an effort to win the franchise.

---

<sup>93</sup> *Brookhaven Cable Television, Inc. v. Kelly*, 573 F.2d 765, established the FCC's authority to preempt in order to promote diversity through development of national pay television services.

<sup>94</sup> *National Association of Regulatory Utility Commissioners (NARUC) v. FCC*, 38 RR 2d 383, US Appeals District Court, 1976.

<sup>95</sup> January 8, 1982, consent decree announced by Justice Green.

<sup>96</sup> This requirement for resources has contributed to the consolidation of the cable industry, and the emergence of dominant Multiple System Operators, i.e., firms which operate multiple cable systems throughout the country.

After applications are submitted, they are reviewed by a committee of the local government. In the past, community groups have attempted to oversee the process to insure adequate community input. Nevertheless, the selection process is often based on favoritism of city officials which results in non-optimal decisions for both the community and the operator. The technology of cable services has become more sophisticated and as a result it is even more difficult for the local governments to both define realistic franchise requirements and to make intelligent and informed decisions. The involvement of the local commercial sector in the franchise definition and selection process could lend some technical expertise necessary. On the other hand, there are potential conflicts of interest that might arise between commercial and community interests. Currently participation by potential commercial users of cable is minimal.

During the next two years the franchising process will come to a close in most of the major cities in the U.S. In the meantime the refranchising process will begin as fifteen year-old franchise contracts begin to expire. Municipalities, operators, and users will have to adjust to a new set of issues and procedures associated with this phase of cable development and operation. In Section 6 we discuss guidelines for making the refranchising process a more enlightened one with regard to data communications.

## 5.3 Cable as Carrier and Broadcaster

### 5.3.1 Introduction

The application of cable systems to data communications raises many questions as to the proper categorization of cable as a broadcast medium. In addition, anti-competitive and first amendment issues are of increased importance because of the expansion of services possible over this medium. Cable could confuse the separation of carriage and content because operators control both facilities and programming. This combined control also has anti-competitive implications<sup>97</sup>. Others argue that although there is only one cable system per

---

<sup>97</sup> R. Pepper noted that traditional anti-trust notions may not provide sufficient protection on these grounds and that a new interpretation of existing precedent may be necessary before anti-trust arguments can be brought to bear (personal communications, March 1982). Because there will generally be only one cable system per community, the available cable spectrum within a city will be limited, in anti-trust terms, a "bottleneck facility". For the sake of our discussion we will refer to anti-competitive implications as opposed to anti-trust.

city there are other competing communication services which prevent cable from acting as a true bottleneck, such as over-the-air television, telephone, digital radio, digital microwave (see Section 4).

If cable does become a significant and unique carrier for information services, it is important that many diverse service-providers be rented access to the cable facilities for transmission to the home<sup>98</sup>. There is concern that the entire spectrum of the facilities not be occupied by the cable operator's own services, nor that the cable operator be given ultimate discretionary powers in refusing or granting transmission service. Historically, common carriage principles have been relied upon to regulate the use of bottleneck resources in our society.

To date the FCC has not clearly determined what the true role of these services should be - broadcasting or common carrier. The FCC has hesitated to effect a separation of carriage and content in cable in response to the argument that without control over programming and the direct service of the subscriber market, cable systems development would be stifled.

Cable operators are, as a whole, opposed to any reference to their services as "common carriage". Common carrier traditionally connotes strict entry and exit regulation, in addition to rate of return regulation, separation of control over content and carriage, and non-discriminatory offering of services to all<sup>99</sup>. Many in the cable industry fear that if the state PUCs perceive these new services as competitive with the telephone company, that the PUCs will attempt to regulate cable according to common carrier guidelines. They believe that given the capital intensiveness of installing a system and the long payback period, rate of return regulation would make their services unprofitable. In particular, the cable industry is concerned that their premium and pay-per-view television profits will be "regulated-away" by rate regulation.

Even if the state PUC's were to agree to classify some of the cable services as common carriage without rate of return regulation, the cable operators remain concerned about the separation of carriage and content, and about non-discriminatory access requirements which

---

<sup>98</sup>In earlier sections of this report we have provided substantial evidence that cable is indeed a unique medium for two-way data communications.

<sup>99</sup>Offering services to all entails a commitment to build facilities on demand. This is discussed further in Chapter 6

might be placed on cable services, including entertainment video. Henry Geller and Ira Barron convincingly argue in a petition to the FCC [27] that regulation of cable services should be on an individual channel basis, as opposed to a system-wide basis, since some parts of the cable are used for traditional broadcast services, and some parts are used, or will be used, for two-way communications of various types. This would insure cable operators their fair profits on pay-per-view services, while insuring the public fair use of the cable spectrum used for "communications", as opposed to "broadcasting" (see 5.3.5).

It is important to examine what common carriage classification implies, and why the protections that it implies are important for cable data communications services. If cable represents a unique communications channel for residential homes and commercial institutions then it is reasonable to consider the cable spectrum to be a limited resource, which is "affected with the public interest."<sup>100</sup> Preceding sections of this report support this notion, i.e., in many communities, cable will indeed be a unique and useful medium for both private and public sectors. It is in the communities' best interests that any unique medium be accessible to all parties on a nondiscriminatory basis.

In Chapter 3.2.2 we discussed the need for multiple server systems in some detail. It is in this capacity, in which the cable operators have no effect on the contents of the communications between parties, that they might be asked to operate in the spirit of a common carrier. The separation of control over content and carriage could obviate the need for special regulation of cable carriage services. The operators' conflict of interest between renting communications capacity to other servers, and offering services over the medium which face competition from these other servers would be eliminated. Complete separation is not feasible in the immediate future for economic, political, and institutional reasons which we discuss below.

Given that the conflict of interest does exist, the community is concerned that the cable operator not infringe on first amendment rights by monopolizing a medium of communications, and that the operator not engage in anti-competitive practices, by monopolizing the cable-based services market. In the past, most public discussion of the potential for First amendment infringement has focused on video entertainment uses of cable.

---

<sup>100</sup> Hale, *Treatise de Portibus Maris*/Harg Law Tracts 78 cited in *Munn vs Illinois* 94 U.S. 113 (1877).

In particular, by controlling all channels on the cable network the operator potentially exerts excessive control over content and thereby limits the diversity of voices and infringes on First amendment rights of subscribers and other programmers. Today, these arguments carry added weight due to the anti-competitive implications of monopoly control over data communications services via cable. It is not only a concern for the private residential community, but for the commercial information service business which plan to offer cable-based services as well, e.g. banks, catalogs, other videotex servers, and entrepreneurs.

Neustadt, Skall, and Hammer outline the three types of regulation that might be applied to "electronic publishing" [47], or for our purposes, two-way data:

1. *Content regulation* promotes the provision of public interest programs, exclusion of offensive and illegal material, and airing of a multiplicity of viewpoints<sup>101</sup>.
2. *Economic regulation* promotes reasonable, nondiscriminatory rates and rate structures.
3. *Structural regulation* promotes efficiency, competition, or diversity of control. As Neustadt, et. al, point out, "(r)ecent regulatory actions have focused in this area, on the theory that competition can achieve many of the goals of content and economic regulation."

Structural regulation is important in establishing a balanced industry structure and regulatory environment which will foster and encourage many diverse parties to develop information and communication services. Economic regulation will develop over time to compensate for inequities which the structural regulation is not able to offset. Content regulation is not necessary for data and information services if structural and economic regulations are able to assure that a multiplicity of voices has access to the medium.

### 5.3.2 Content regulation

Content regulation, as applied to television broadcasting, was an attempt to address the

---

<sup>101</sup>Title III, Communications Act, 47 U.S.C. 201 (1934)

scarcity of broadcast channels<sup>102</sup>. It is argued that these regulations have not enhanced the quality or variety of programming and have merely served to limit the First Amendment rights of the broadcasters. In the case of data, scarcity is also a concern but content regulation does not appear to be an appropriate means of addressing the problem, for reasons described below.<sup>103</sup>

Because of the transactional nature of the two-way information services discussed, subscribers do not require the "protection" that some content regulation is intended to provide, i.e., from obscenities. This transactional nature provides for user discrimination, not necessarily available on broadcast television where there are a scarcity of channels (other than by turning off the receiver altogether). It is also important to note that the mere quantities of information available from non-broadcast information services make enforcement of content regulations infeasible<sup>104</sup>.

In the provision of communication services, content regulation is particularly undesirable because the implied responsibility for matters of content prevents the operator from behaving like a common carrier; a far more appropriate model for a communications facility.

---

<sup>102</sup>The areas in which content regulations are currently applied by the FCC include:

- Fairness doctrine -- equal treatment of editorial subject matter.
- Personal attack corollary -- right of an individual to access in order to defend himself/herself against personal attack on the media.
- Political broadcasting rules -- equal access to all candidates.
- Local origination -- channels where the operator is the only designated programmer.
- Obscenity -- restriction of certain material considered offensive to the community.
- Advertising codes -- legal and fair advertising practices.

<sup>103</sup>Content regulation is not applicable to regulation of data communications services, in which the service provider exerts no control over the content of the communications; but, the inapplicability to information services is somewhat less clearcut.

<sup>104</sup>The amount of information stored in a data base is not limited by the communication channel via which it is accessed, but by the practical limitations of the access procedure, i.e., how hard it is for a user to find something in a very large data base.



### 5.3.3 Economic regulation

Rate regulation is used in the case of most public utilities, including telephone, and could conceivably be applied to cable. The objective is to limit the utility's ability to extract monopoly profits on the basis of its natural or granted monopoly, and to insure nondiscriminatory pricing structures. Rates are typically set according to an allowed rate of return (ROR) on the firm's investments, or rate base. The rate structure is also evaluated to assure equal access to all users. The history of rate regulation is checkered. The regulated utilities (e.g., gas, electric, telephone) have been burdened with the slow administrative processes necessary to enforce the regulation (regulatory lag); these are particularly difficult in times of high inflation. Some economists believe that the consumer has also been burdened by the hypothesized tendency of utilities to over-capitalize and thereby increase their rate base [7].

There are a number of reasons why it is desirable to avoid traditional rate regulation in the case of data over cable. In addition to the imperfections of implementing traditional rate regulation, the disincentive it would pose to cable operators might stifle development. Currently, cable operators are not subject to traditional rate regulation apart from local constraints on basic, premium, and pay-per-view television subscriber fees. By entering the uncharted market of two-way communications services they would face both uncertain revenue streams and a restricted return on them as well; in addition, there is the possibility that this regulation might be extended to other cable services such as premium and pay-per-view television. On the other hand, given that the cable facility is to some extent a unique municipal facility, it might be desirable to restrain the potential monopoly power of the operator.

Access or service charges will be paid by both subscribers and information service providers. Subscribers will pay fees to the cable operator for access, and/or to the data base vendor for the information which is accessed or provided. Cable access fees are already monitored by the local franchise boards and state legislatures. Regulation of the data base rates is widely viewed as inappropriate because of growing competition in the "information marketplace" which is believed will effect efficient pricing. In particular, we are hesitant to mandate "proper" rates for pieces of information. Therefore, there appears no particular need for additional rate regulation of subscriber fees.

The problem of service provider access and communication rates is more difficult. In the case of two-way data communications services, the situation is analogous to a specialized common carrier operating in the local loop. But, because there is generally only one cable system per municipality and the franchise is granted by the city, monopoly power does exist in so far as the cable facilities offer more than other available local loop facilities do (i.e., bandwidth, transmission quality, etc.). There are two primary concerns associated with this monopoly power. The first might arise if cable operators want to use all upstream channels to carry the return traffic of pay-per-view television or information services, instead of data communications services. They could set the access rates to data communication users high enough to dissuade potential business users while still complying with any structural requirements set out in the franchise. The second concern is that monopoly rates will be set too high above marginal cost, resulting in the traditional monopoly inefficiencies of excessively high rates and accompanying underutilization.

Rates charged to data base vendors will undergo even more distortion because cable operators will typically be acting as data base vendors themselves. Therefore there is conflict of interest between selling carriage capacity and competing for the sale of information and transaction services. The cable operator could use excessively high rates to discourage information providers from using the cable medium, thereby retaining a monopoly for the operator. As we will discuss in the following Section 5.3.4, structural regulation is likely to be the most effective means of preventing such abuses, although it is probable that at times some economic regulations may be needed to account for remaining market imperfections.

#### **5.3.4 Structural regulation**

There are two elements of current cable industry structure which in combination might lead to abuse:

1. The control of both carriage and content by the operator.
2. The practical monopoly which the operator has over cable facilities within the franchised city.

If cable offers an advantage over other competing media the operator could wield significant monopoly power; resulting in excessive rates, as well excessive control over the content of communications.

The cable operators argue that cable is not a monopoly since there are competing technologies, e.g., telephone, airwaves, newspapers. For certain services alternative forms of distribution are equally attractive. But, for wide bandwidth, two-way applications, cable offers a clear advantage. For example, one-way textual information might be just as suitably transmitted via over the air teletext<sup>105</sup>, whereas videotex graphics or high speed computer to computer communications is not available at comparable costs on any other existing facilities (see Section 4). Content and economic regulations could be applied in an attempt to prevent abuse. But, it is more effective and efficient to attack the origin of the problem, i.e., the structure which permits conflict of interest.

The tools of structural regulation include:

**1. Entry.**

**2. Limitations on horizontal integration -- control over multiple channels.**

**3. Limitations on vertical integration -- separation.**

Although most municipalities do not grant exclusive franchises, the economic barriers to constructing a second cable facility in a municipality are high<sup>106</sup> and there are few examples of competing companies. Therefore, entry policies are not effective at this point in time<sup>107</sup>.

Limitations on vertical integration by definition would entail some degree of separations policy to isolate the control over carriage and content. Limitations on horizontal integration would also entail some degree of separations. Horizontal integration refers to the control over multiple channels. If cable operators give up control over a portion of the channels on the cable they will nevertheless be responsible for the carriage of those signals. Therefore, on a portion of the network they would be acting as carriers only, which is equivalent to limited separations.

Separations would require that the cable network operator completely separate its signal

---

<sup>105</sup> Teletext information is transmitted during the vertical blanking intervals (VBI) of television transmission.

<sup>106</sup> Exclusive franchise contracts may be held in violation of antitrust laws, see *Community Communications Co. v. City of Boulder*, 830 F. 2d 704, 1980.

<sup>107</sup> We might imagine that in the future, demand will exceed the supply of cable channels and at that time, entry provisions regarding additional cable facilities may be effective.

transmission functions (i.e., carriage) from its programming functions (i.e., content) . The cable operators insist that services would be sacrificed by limiting the incentives of cable operators to enter both markets. In addition they feel that in order to attract an adequate revenue stream, control over the entire package, both content and transmission, is necessary<sup>108</sup>. The cable industry also argues that separations regulation is in abridgment of both the first and fifth amendments: the first through constraint of content control by the operator, and the fifth through constraint of due process of the cable operator to earn a fair return on the facility. In support of their first amendment position, the National Cable Television Association (NCTA) has argued that "cable systems should be treated in the same manner as newspapers." [13]

Separations was rejected as a policy alternative in both the 1972 and 1974 *Cable Television Report and Order* [14]. In 1976 the house subcommittee expressed the importance of separations as soon as it became "feasible" but agreed that 1976 was too soon to do so [19]. In 1979 the court found that "(a) business or group of businesses in control of a scarce facility have an obligation to give competitors reasonable access"<sup>109</sup>. Proposals have since been made for limited separations policies such as leased access. These are more favorable to the cable industry and are more likely to be implemented. Leased access will be discussed in Section 5.3.5

Public utility regulation of cable is another possible model for cable regulation. It has recently been applied to new institutional networks, such as the one in New Orleans [20], which will be used primarily as transmission networks for business and government. In California legislation was proposed to declare all cable communications systems public utilities to be regulated by the state PUC<sup>110</sup>. The bill would require "separation of system operation from programming selection." [28], [16]. State legislation of this sort is particularly a reaction to the Boulder decision made in January of 1982 which stated that municipalities were not in fact exempt from antitrust laws unless they are furthering "a clearly articulated and affirmatively

---

<sup>108</sup> Prestel, the videotex service in the United Kingdom, operates under a separation principle but does not face impediments such as franchises and cable systems.

<sup>109</sup> *Byars v. Bluff City News Company, Inc.*, 608 F 2d 843, 856 (6th circuit, 1979) [47]

<sup>110</sup> The Cable Communications Act of 1982, California AB 2742, introduced by Assemblyman Richard Robinson, Santa Ana.

expressed state policy"<sup>111</sup>. This decision threatens the status of municipally franchised cable systems in those states whose laws do not expressly assign the municipalities jurisdiction over cable. The most often stated opposition to municipal control is the tendency of municipal ownership to reduce innovation and efficiency.

Although structural regulation is ordinarily considered preferable to content and economic regulation, L. Auerbach cautions that structural regulation alone should not be depended upon to achieve society's goals [6].

The characterization of a highway operator providing 'non-discriminatory' and 'equal' access (subject only to economic and technical feasibility) masks the policy importance of choosing between alternative technical and economic criteria for access. In fact, since these criteria will constrain access by some but not by others, the interesting questions then become ones of deciding how, and in what ways, technical and economic limitations should be allowed to determine access to the Electronic Highway, both by potential consumers and producers of information. Perhaps, in view of these limitations to access, other social and political criteria (such as the 'public interest') should also be used. Economic criteria, by definition, discriminate on the basis of ability to pay. This is not always a socially or politically optimum outcome."

As Auerbach points out, through structural regulation discriminatory practices attributable to conflict of interest can be eliminated; but, discrimination on the basis of ability to pay remains. This in turn necessarily influences content. Therefore, although we see structural regulation as the best of existing practical alternatives, we realize that communities may need to bring to bear supplementary mechanisms, such as public and government access in, in order to achieve social and political goals. We take heed of Auerbach's caveat [6]:

Arguing for separation of carriage and content will subsume the most important sociopolitical questions under an apparently technical distinction and, even worse, may encourage people in the complacent assumption that the mere assertion of two mutually exclusive categories will solve the boundary issue implicit in making the distinction in the first place. There is no need to suffer from what Alfred North Whitehead once called the 'fallacy of misplaced concreteness'<sup>112</sup>.

---

<sup>111</sup> *Community Communications Co. v. City of Boulder*, 630 F. 2d 704, 1980.

<sup>112</sup> Alfred North Whitehead, *Science and the Modern World*, New American Library, New York, 1948, pg. 58.

### 5.3.5 Leased channel access

Provisions for *Leased channel access* have been suggested as a means of protecting both consumers and businesses from possible monopolizing tendencies of cable operators. These provisions would require that the operator allocate a certain number of its channels to be offered on a common carrier basis. This might imply non-discriminatory, first-come-first-served access, with no control over message content by the cable operator. The implication of leased access for video cable services is the allocation of a certain percentage of downstream programming to parties other than the cable operator. The implication for interactive data services on residential systems is the allocation of some percentage of possibly both downstream and upstream capacity to multiple information providers. For such allocation to be of use to other information providers, subscribers must be able to address parties other than the cable operator.

Mandatory leased access could prevent overcharges to subscribers through competition while avoiding the disincentives posed by complete separations and common carrier policy. Economic regulation of subscriber rates might be avoided as a result of competing services on the system. Similarly, content regulation will not be necessary given the diversity of sources. Recognizing the difficulty of enforcing complete separations, it is wise to enforce leased access in the near future so as to establish the process early on in operation and to encourage the emergence of service providers [47].

The petition to the FCC prepared by Geller and Barron presents a legal discussion of the appropriate jurisdictional position of the FCC in regulating leased access [27]. It concludes that the FCC does have jurisdiction to establish guidelines for *leased channel access* because of the interstate nature of some communications, now and in the future when interconnection of cable networks is in place. The rulings which have served to limit FCC regulatory jurisdiction are discussed in detail and can be shown to be inapplicable given the true "communications" nature of the data communications services under discussion here. That is, instead of these services being "ancillary to broadcasting", they are in fact "ancillary to common carriage". This being the case, the ruling in *Midwest Video II* which held that leased access requirements were in conflict with the broadcast categorization of cable function, would not hold since there is no conflict between leased access requirements and common carriage. Fundamental to this approach is the treatment of each cable service or channel

separately, according to its function. Only in this way can the appropriate regulations be applied to some services, without unnecessarily harming other services.

A disincentive to cable operators is the vulnerability of cable to state common carrier regulation if leased access is offered. Preemption of the states right to enforce rate of return regulation is the approach recommended by the industry. An alternative measure is to enforce the model suggestion by Geller and Barron whereby each channel is regulated (or not regulated) separately, and therefore some subset of channels might be offered on a common carriage basis without threatening all cable services.

Fundamental questions arise in the implementation of leased access<sup>113</sup>:

- Who should set the rates on access to the available channel -- the cable operator? The state PUC? The FCC? According to what criteria should these rates be set?
- How will leased access requirements impact the status of *joint ventures* between information service providers and cable operators?
- What provisions should be made in the event that the allocated number of leased access channels become crowded? Should the number of Leased Access channels required be raised? Should separations be enforced since the market for servers will have been proven?
- How to ensure equal treatment for those services that might compete with services offered by the cable operator; As Neustadt et. al. state, "(p)olicing equal treatment is a regulatory swamp".
- What central head-end services are included in the leasing of a channel?

Geller and Barron propose that initially pricing be left to the forces of market supply and demand. It seems reasonable that this be attempted, but with close monitoring, so that discriminatory or unfair behavior is detected quickly, and the need for regulatory remedies can be reevaluated. It would be inappropriate for the state PUC's to establish a rate of return policy for these new services unless discriminatory practices arise. Rate-base regulation of mixed services provided by shared telephone plant has been fraught with economic as well as political problems and the desire to avoid this complication, if possible, is shared by both the

---

<sup>113</sup> Some of these questions will be addressed in the following chapter on municipal and state cable policy.

public and private sectors. But, if the cable operator sets rates artificially high so as to discourage leasing of channels by competing service providers, or if the operator exhibits other anti-competitive behaviors, economic regulation may be called for. One alternative is to implement a bidding system, such as has been tried for satellite transponders, whereby both the cable operator and other information providers bid for use of a channel, or a subset thereof.

The cable industry presents a number of arguments against leased access requirements:

1. The cost of building a system is only justifiable if the operator has control over all revenue producing channels.
2. Leased access requirements burden the operator with added costs of managing individual channels.
3. Subscribers will hold the operator responsible for the quality of all services, even those over which the operator has no control.

The first argument ignores the fact that each channel will be leased and therefore will be a source of revenue. In particular, on large systems where there may be excess channel capacity, the opportunity cost on the nth channel is low and the operator is likely to make a profit through leasing. In addition the channel leasing rate will reflect any additional system cost that the operator incurs in providing the channel. Significant additional costs will be incurred by the operator when channel space becomes scarce and the need to increase network capacity arises. This is a capital and labor intensive process and will have to be addressed by the local and state authorities.

Although it is true that the quality of each service is likely to affect the overall subscriber impression of the cable service, the incentive to the new services should be equally high to improve business and provide as good service as is necessary.

There is some hesitancy on the part of potential service providers to actively support Leased Channel Access Requirements, due to the potential negative impact on joint ventures. In particular, Leased Access requirements might establish a precedent that would later be used to prevent exclusive Joint Ventures between a cable operator and a service provider.

Many implementation questions will be overseen by local cable authorities and are therefore addressed in the following chapter on policy guidelines.



### 5.3.6 Telephone company cross ownership

The FCC adopted a ban on local telephone and cable television cross-ownership<sup>114</sup> in hope of encouraging "the full development of non-cable services (e.g., data services) that could be substituted for traditional telephone services." This was upheld in *General Telephone Co. of the Southwest v. U.S.*<sup>115</sup>. It is on this same basis that cable operators might be restricted from exerting monopoly control over the facilities.

The access charges to local loop facilities are of increasing importance in light of the proposed separation of Bell Operating Companies (BOCs) from AT&T<sup>116</sup>. It is possible that the BOCs will be allowed to enter the cable market. Alternatively the telephone companies might lease channels from the cable operator. It is not evident to what degree the telephone companies will pressure the state PUCs to more heavily regulate cable. The aggressiveness of the cable companies in offering high speed data services will invariably affect this outcome, but how is not so clear. For instance, if cable operators are slow to offer these services the state or federal officials might open the market to the telephone companies. On the other hand, if the cable operators aggressively enter the data communication markets and threaten the telephone companies, the state officials might enforce additional regulation under pressure, or in protection of the local telephone companies.

## 5.4 Privacy -- Wiretapping, Intrusion, Misuse of Information

Centralization of the control over content and carriage also increases the dangers of privacy violation. All home information systems are a danger to personal privacy by the mere fact that they provide a channel by which information can flow from within one's home to the outside world. But the more direct the connection between the information source and sink, the more motivation there is for invasion of the individual's privacy. D.C. Nash and D.A. Bollier describe four types of exposure that consumers risk with interactive home media: intrusion, interception, misuse of information and aggregation of individual or household

---

<sup>114</sup> 47 C.F.R. 63.54-56; *Report and Order* in Docket No. 18509, 21 FCC 2d 307, 308

<sup>115</sup> 449 F 2d 846 (5th circuit, 1971)

<sup>116</sup> *AT&T v. U.S.*, Consent Decree, January 8, 1982; Justice Green presiding

information [45]. The diversity of channels through which we currently communicate with others has helped to shelter us from these abuses, i.e., telephone, postal mail, on-site business transactions.

Cable systems pose privacy problems, some of which are common to many electronic communications, information, and transaction services, and some of which are particular to cable. Problems which arise from wiretapping on cable are not qualitatively different than wiretapping on the telephone system.<sup>117</sup> Encryption can provide a solution to large users whose volume of communication warrants the cost of encryption equipment, but it is not likely to be feasible for private residential subscribers until incorporation of encryption devices such as the Data Encryption Standard (DES) is economically practical<sup>118</sup>. The network itself might offer encryption as a value added service, as a way of offloading the front-end costs. Currently, the cost of operating this value added service is considered prohibitive for most systems. In conclusion, the problems of secure communications and wiretapping are compounded by foreseen cable data communication services, but are not unique.

Intrusion via the communications media is a fear that is deeper than a "1984 paranoia". Security and home monitoring systems, as well as energy management services all form a new avenue for the flow of information out of the home, in particular, automatic generation of information, which is not regularly filtered by the residents. This fear has lead some service providers to give the resident the capacity to turn off all monitoring services at will, but in general, the monitoring is continual and altogether transparent to the resident. It is likely that the only alternative to intrusion for those who are cognizant of it, will simply be non-participation.

A less direct, but profound form of intrusion will come through the misuse of information collected from the home. An example is billing information indicating the viewing habits of individual subscribers. On some systems that are highly centralized, this would include the information retrieval, and transaction habits of subscribers. The use of both aggregate and

---

<sup>117</sup> Although, as described in Section 2.3.2.2, wiretapping and traffic analysis are both significantly easier on shared channel cable systems.

<sup>118</sup> To some extent, it will not become practical until the residential market exhibits a demand for secure communications, i.e., that there is a willingness to pay for the added cost to equipment.

individual data by marketing firms alone could lead to unfair and invasive generation of special interest mailing lists. The misuse of information by credit and insurance bureaus is already an issue of public concern. Prevention of the misuse of cable data would benefit from stronger and more enforceable general legislation. But in addition, because of the ease with which valuable information can be gathered on cable systems, and because this information can be gathered from points other than the head-end, these systems might require close monitoring by federal and local authorities. This will be in the interest of both subscribers, and the service providers, whose services will eventually suffer significantly, if the clientele cannot trust the security and privacy of their communications. Warner Amex has proposed the code of privacy shown in Figure 5-0:

### Warner Amex code of privacy

Warner Amex Cable Communications has prepared a privacy code detailing the rights of subscribers on its two-way cable television service.

- Warner Amex shall explain to its subscribers the information gathering functions of the cable communications services being provided.

- Warner Amex shall maintain adequate safeguards to ensure the physical security and confidentiality of any subscriber information.

- Warner Amex subscriber agreements shall include the following:

Individual subscriber viewing or responses may be recognized only where necessary to permit billing or to render a subscriber service. Any such information will be kept strictly confidential unless publication is an inherent part of the service (e.g., announcing a game show prizewinner).

No other individualized information concerning viewing or responses will be developed unless the subscriber has been advised in advance and given adequate opportunity not to participate.

- Warner Amex may develop bulk

(non-individual) data concerning subscriber services for use in developing new services or improving existing services. Warner Amex will not make such bulk data available to third parties—whether affiliated or non-affiliated with Warner Amex—without first ensuring that the identity of individuals is not ascertainable from the data provided.

- Warner Amex will refuse requests to make any individual subscriber information available to government agencies in the absence of legal compulsion, i.e., court order, subpoena. If requests for such information are made, Warner Amex will promptly notify the subscriber prior to responding if permitted to do so by law.

- Subscribers may examine and copy any information developed by Warner Amex pertaining to them at Warner Amex premises upon reasonable notice and during regular business hours. Copying costs shall be borne by the subscriber. Warner Amex shall correct such records upon a reasonable show-

ing by the subscriber that information contained therein is inaccurate.

- Any individual subscriber information will be retained for only as long as is reasonably necessary, e.g., to verify billings.

- Subscriber mailing lists shall not be made available to third parties—whether affiliated or nonaffiliated with Warner Amex—without first providing subscribers with the opportunity to have their names removed from such lists.

- Warner Amex shall comply with applicable federal, state and local laws respecting subscriber privacy and shall adhere to applicable industry codes of conduct which promote or enhance subscriber privacy.

- Third parties who participate in providing services to Warner Amex subscribers shall be required to adhere to the company's Code of Privacy and all Warner Amex arrangements regarding such services shall specifically incorporate this Code of Privacy by reference.

- Warner Amex shall continuously review and update its Code of Privacy to keep current with technological changes and new applications.

Figure 5-1: Warner Amex Code of Privacy (CableVision<sup>119</sup>).

Although this code is an important step in industry recognition of subscriber rights, it does not adequately address two particular sources of potential abuse. If the cable operator sells

<sup>119</sup> CableVision [65]

information services, access to market information which is specifically restricted from other parties, i.e., "individualized information concerning viewing or responses", can provide the operator with a competitive advantage over other information services. A related issue is the storage of data in a form that is traceable to individuals. If information is not to be used for purposes other than billing, some citizen groups have suggested that other information only be stored in statistically aggregated form [40].

All information collected about subscribers by the Operator or by any independent access corporation, other than billing information, shall be stored only as aggregated statistical totals not identifiable as to individuals except to the extent allowed by the prior written consent of the subscriber...

## 5.5 Summary

Federal cable television regulation grew during the 1960's and early 1970's, culminating in the 1972 Cable Television Report and Order. Since the mid-1970's regulation has subsided. Throughout this cycle, regulatory and deregulatory provisions focused on cable television as a one-way video distribution technology. Nevertheless, the fundamental regulatory issue that remains unresolved, namely cable television's status as a common carrier or broadcaster, is also the issue of most significance to the application of cable television networks to two-way data communications. Structural regulations have been proposed to eliminate the potential for conflict of interest on the part of the cable operator. These regulations would assure equal access to the distribution medium while at the same time isolating content-related decisions from government intervention. Separations, eliminates this conflict, but the cable industry believes that such severe action will leave cable operators in an economically uncertain position. Leased channel access is a limited form of separations that is more acceptable to the cable industry but which might entail more cumbersome rate-setting or monitoring procedures. We support prompt construction of structural regulations that will establish cable television as a local distribution medium, accessible to a multiplicity of voices and listeners.

In the final Chapter which follows, we integrate the technical and regulatory information presented thus far into policy recommendations for city cable authorities.

# Chapter Six

## Guidelines for municipal policies

### 6.1 Introduction

In the introduction we discussed the applications that might motivate cities and cable operators to implement data communications services on cable television networks. In subsequent chapters (see Chapters 2, 3, and 5) we discussed the technical capabilities and operational mechanisms that are needed to implement these applications. The local government, via a designated cable authority, influences the design and operation of the city cable network through the franchising process, interim reviews of performance, and the re-franchising process. There are many requirements and concerns which the local cable authority must consider at these times. Due to political and economic constraints, only a subset of these can be addressed and implemented. We hope to aid local authorities in identifying and addressing those requirements that are of greatest consequence to the implementation of data communication services that will serve community goals.

Data communications capability is viewed as the fundamental infrastructure of the cable network because it is the basis for provision of information and transaction services to residents, as well as high and medium speed data communications and networking to institutional users. It is not evident to what extent the cities must formulate detailed specifications for this infrastructure in order to achieve the community's goals.

In this chapter we discuss the relevance of data communications services to the satisfaction of city goals. We first identify particular goals and derive their implications for use and operation of cable networks for data communication services. We then review and highlight the technical capabilities and operational mechanisms that must be in place for the city to realize these goals, and the role of the cable authority in specifying and overseeing the implied capabilities and mechanisms. We refer the reader to Chapters 2 and 3 for further discussion of technical details.

Throughout this chapter we present cases in which it might be appropriate for the city cable authority to exert external pressures on the cable operator. We wish to emphasize to cable authorities the detriment that could be caused by overcommitting the cable operator. Overcommitment can result in an operator that is unable to acquire financing, or is unable to complete construction. Over-ambitious specifications may also discourage the best-equipped vendor from bidding; leaving only the uninitiated or dishonest vendor to bid. Therefore, the authority should be prudent in its demands.

## 6.2 City goals and the role of data services

Two fundamental city goals can be served by data communications services:

1. To provide residents with enriching facilities and services that will both raise the "quality of life" and contribute to the economic status of the city. Home information services can provide convenience, entertainment, access to useful information, and formal education. A two-way cable television network is an economical and powerful means of transmitting these services (see Chapter 4).
2. To provide an environment that is attractive to the business community and thereby contributes to the strength of the economy of the city. High capability, low cost, business communication facilities and services enhance the overall business environment, particularly in light of increasing use of communicating office computers. A two-way institutional cable network is an attractive alternative to the telephone company's local loop, both in terms of performance and economics.

Once a city decides that these facilities are in fact desirable, there is a second tier of three goals which concerns the type and quality of service offered via these facilities:

1. A maximum number of servers -- information and service providers -- should have access to the facilities in support of the first amendment goal to promote freedom of the press; one factor in promoting such freedom is assuring equal access to the "public" media by a diversity of voices. To this end, the cable operator should not be the only service provider on the network, nor should it have the power arbitrarily to exclude other service providers. The operational policy needed to realize this goal is structural regulation such as leased access that will eliminate the conflict of interest which arises from control over both content and carriage<sup>120</sup>. The technical requirement implied by this goal are communications facilities that support multiple servers (see Section 3.2.2).

---

<sup>120</sup>Cable authorities may find that additional economic regulation is needed to ensure the effectiveness of leased access policies, see Chapter 5.

2. The maximum number of residences and businesses in the community should have access to services at the minimum reasonable rates, i.e., rates that are close to the marginal cost of providing service. The potential monopoly power of the cable operator might allow the operator to set prices above marginal cost. Therefore, the city should actively promote competitive rate levels and structures through promotion of competing service providers and transmission media, where possible, and through monitoring of rates, where competition is not feasible. In addition, it should not encourage overbuilding, which will result in excessive subscriber rates.

3. The city should not be precluded from enjoying future services because of obsolete facilities. Therefore, the facilities must be designed and constructed to achieve (or at least not preclude) flexibility, performance, and minimum costs in the long-term, as opposed to specific functions and minimum costs in the short term. The city must understand the technology sufficiently to evaluate the proposals of the operator and to formulate demands that will enforce long-term yet reasonable investment on the part of the operator; in particular, network configuration, reduction of upstream noise, and multiple server addressing capabilities.

Data communications requirements must be balanced with other community goals relating to cable television; namely, influence over programming decisions, rate setting, channel capacity, and local origination facilities.

### **6.3 Entry points for municipal input**

Cable policy at the local level is traditionally formulated and implemented via the franchising process. The local cable authority identifies and advertises system requirements in a request for proposal (RFP) and selects from among the responding cable operators. The cable network criteria proposed by the city are then modified through a series of negotiations with the cable operators (see Figure 6-0).

By the end of 1982, most of the major cities in the U.S. will have completed this franchising process. Thereafter, local governments will use interim reviews and refranchising processes as the forums for establishing cable policy, in particular for overseeing cable operation and expansion (see Figure 6-0, phase 6).

Franchises granted in the mid and late 1960's are coming due for contract renewal. These systems are primarily six to twenty channel networks located in rural areas, where cable was

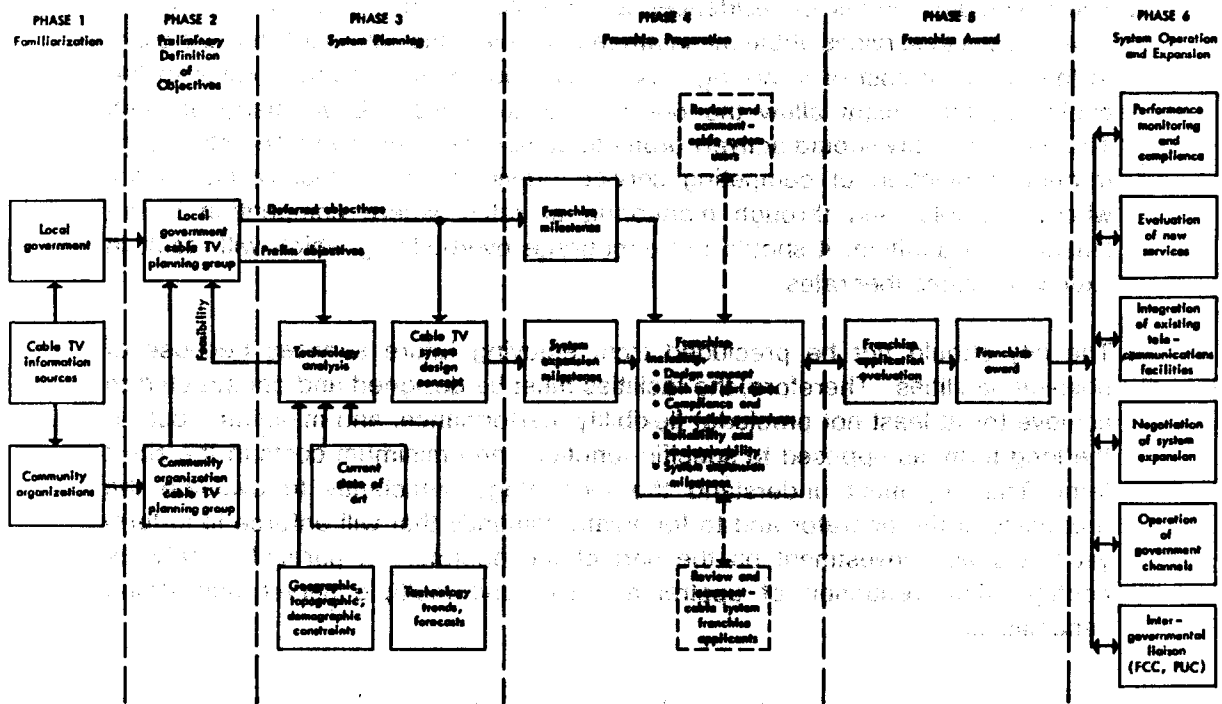

Figure 6-1: Cable television system franchising (*Cable Television: Franchising Considerations*<sup>121</sup>)

installed because of poor over-the-air television signal reception. Systems located in densely populated areas with large potential cable markets will be rebuilt or upgraded into higher capacity systems, particularly those currently in the six to twelve channel range. Those areas that are sparsely populated do not offer large enough markets to warrant installation of high capacity two-way systems. Therefore, in these communities, cable operators are unlikely to install the higher cost facilities necessary for two-way data communications capability<sup>122</sup>.

The post-1972<sup>123</sup> franchises typically have 25 or more channels and therefore many of these systems do not require rebuilding. Instead of developing specifications for a new system, the cable authorities will use the refranchising process to:

<sup>121</sup> Baer, W. [8]

<sup>122</sup> In 1980 there were 358 systems of 30 channels and above, 758 systems of 20 to 29 channels, 103 systems of 13 to 19 channels, 2,793 of six to twelve channels, 151 systems of below six channels, in the United States [46].

<sup>123</sup> In 1972 the Cable Television Report and Order established technical requirements for cable networks for all new systems that would serve over 3500 subscribers, see Chapter 5.



1. Ensure that franchise promises have been implemented.

2. Propose new system capabilities.

3. Establish or modify operational procedures.

Most of the post-1972 franchises also provided for interim reviews by the local authority. These reviews can also be used to monitor cable operator performance in meeting franchise agreements, negotiate for additional capabilities, and provide a channel for community members to express desires to the operator.

Although interim reviews and refranchising negotiations are in some ways similar to the initial franchising process, the scope of issues to be resolved is considerably narrowed. For example, instead of overseeing network design and construction, the cities oversee upgrading, or at most rebuilding, of the existing network<sup>124</sup>. In addition, if the cable operator has performed well, or if the franchise is an exclusive one, the city might forego the operator selection process.

Despite this narrowed scope, substantial issues remain for the city cable authority to address; in particular, unsatisfactory or deficient operational procedures and technical capabilities (see Figure 6-0, phase 6, performance monitoring and operation). Many desirable technical capabilities were not implemented in the original systems because they were either unforeseen or considered too risky by the cable operator (*ibid*, phase 6, evaluation of new services). Most refranchising demands do not entail the high costs that initial cable installation does. Therefore, depending upon the specific market characteristics, the operator might be more able and willing to implement capabilities which have longer payback periods (*ibid*, phase 6 negotiation of system expansion). Also, depending upon the cable penetration figures on the existing system, the operator may actively seek new features which will attract new subscribers.

---

<sup>124</sup>For the remainder of our discussion refranchising will refer to those systems that only require upgrading and contained amounts of rebuilding. The refranchising process for systems which require extensive rebuilding or replacement will be considered identical to an original franchising process.

## 6.4 Community requirements

*Two-way capability and leased access policies are necessary to ensure implementation of data communication services that will serve the spirit of the community goals discussed above.*

The application of cable television networks to data communications presents complexities and uncertainties which exceed the expertise of most city cable authorities, as well as most cable operators. As Baer and Pinick point out, technical specifications and operational procedures which were acceptable in the past for entertainment television are not necessarily adequate for data communications applications [8]. In addition, the larger capital investment necessary contributes to the financial burden of both the operator and subscriber.

The heart of the problem is that a cable system good enough for TV entertainment may simply not be good enough for many non-entertainment services.

Communities have no easy solutions to turn to. Since most new services are, by definition, untested at this time, franchising authorities cannot specify a cable system design that will meet all future requirements. The more flexibility and the more stringent standards they require, the more the system will cost above one oriented primarily toward entertainment services.

Most cities have not faced the question of who will pay this additional cost... (If) the added system cost cannot be justified initially, franchising authorities should at least be aware that many future services may be diminished in scope or foreclosed entirely.

In the following section we draw on details provided in earlier chapters to qualify and bound the rather dreary picture painted by Baer, et. al. Their statement is representative of uncertainties which were pervasive in 1975, many of which can now be resolved. The technical and market uncertainties create financial uncertainties which inhibit investment. This discussion should serve to encourage such investment, where practical, and to promote intelligent construction and operation of the facilities.

#### 6.4.1 Technical requirements

Two-way capability is the most fundamental technical requirement for data communications. As we saw in Chapter 2, two-way capacity can be implemented in many different ways, resulting in widely varying capabilities. *Therefore, many cities will find it insufficient to specify merely "two-way capability" in the review, refranchising, or franchising processes.* The extent to which the cable authority should establish the technical specifications for two-way capacity is unclear; but, cities must at least deepen their understanding of these issues so as to prepare themselves for evaluating the cable operator's plans and performance. In this section we highlight points made in Chapters 2, and 3 in the context of formulating local policy. We refer the reader to those chapters for further discussion of technical details.

The FCC has identified four classes of cable television channel, the fourth of which refers to upstream transmission<sup>125</sup>. A Class IV channel is defined as "(a) signalling path provided by a cable television system to transmit signals of any type from a subscriber terminal to another point in the cable system." This definition does not specify many capabilities that are necessary to implement the data communication schemes described in Chapter 2. Not all of the requirements discussed in the following section need be mandated by the cable authority. The cable operator will find many of them attractive enough to adopt without external pressure, and others can be added incrementally. But, the authority should understand the technical trade-offs sufficiently to identify those capabilities that are fundamental to the implementation of data communications services, that cannot be added incrementally, and that therefore warrant long-term investments.

If the operator is motivated or experienced in two-way data communications, then the city might confidently leave many of the detailed specification to the operator. But, the city must make certain that the provisions agreed upon are specified in enough detail to ensure that a system results which will accommodate the types of services desired by the community, in addition to those desired by the cable operator.

---

<sup>125</sup>The first three classes of cable television channel are defined as follow: a Class I channel carries one-way signals that are received by the operator over the air or are obtained by microwave or by direct connection to a television broadcast station; a Class II channel carries one-way signals that can be received by a television broadcast receiver without the use of an auxiliary decoding device, and that are not part of broadcast transmission path; a Class III channel carries signals that are intended for reception by equipment other than a broadcast receiver, or by a receiver that is equipped with special decoding equipment [15]

#### 6.4.1.1 Engineered for data

In Chapter 2 we identified the design parameters that must be implemented in order to accommodate data communications on a cable television network. We review them here in the context of franchising, refranchising, and interim review processes.

The two-way communications capacity available depends, in the first instance, upon the type of two-way amplifiers used. Subsplit amplifiers are typically used in residential networks and will accommodate four upstream TV-size channels. Some cable operators may prefer to satisfy two-way requirements with a hybrid system which uses the standard telephone lines as the upstream channel. Many of the transaction services envisioned for the residential network require only limited upstream transmission. The limited data rates economically achieved over telephone lines (typically 300 baud, see Section 4) will be adequate for these applications. In particular, hybrid facilities will allow the cable operator to offer pay television services without having to implement "real" two-way transmission capabilities on the cable network. In the long run, we envision applications that will require larger bandwidths in both directions (see Chapter 1). In addition, as we discussed in Chapter 4, it is not desirable to tie up the only telephone line into the home. Some cities do not envision heavy usage of two-way services in the near term, and would therefore agree to the use of hybrid facilities to fulfill two-way franchise requirements. It should be noted that in so doing the cities may significantly reduce the cable operator's incentive to implement "real" two-way capabilities in the future, namely by enabling the implementation of pay-per-view services. The authority should be aware of the limitations and implications of such a decision, while appreciating the positive economics of the hybrid approach in some instances.

A primary requirement for two-way transmission, in addition to the presence of two-way amplifiers, is minimization of the insertion noise on upstream channels. This is achieved by minimizing the cable length between the head-end and the farthest subscriber. The system configuration should resemble a hub, with radially extending trunks, as opposed to a christmas tree or snake with long winding trunks. In larger communities sub-hubbing, multiple hubs interconnected by microwave links or cable trunks consisting of lower-attenuation, higher-cost coaxial cable, may be needed to cover the extended geographical area. In the case of refranchising, system configuration decisions are constrained since facilities are already in place. If the system being upgraded to accommodate two-way

transmission is poorly configured, other mechanisms for reducing noise on the upstream channels must be brought to bear. These engineering details are primarily in the domain of the cable operator and should be recognized as such by the cable authority. But, the authority would do well to understand the implications of these fundamental parameters so that operator performance can be intelligently monitored; for instance, when reviewing the proposed cable network layout, the authority should be prepared to understand why multiple hubs and other design choices were, or were not, made. Following is an excerpt from the New Orleans cable franchise which exemplifies how technical provisions might be incorporated into a franchise document [20]:

If necessary to prevent the build-up of noise and distortion products, the area shall be divided into sections, and sub-trunks run to a central hub within the area. Equivalent alternatives such as addressable taps or switches may be utilized.

As we discuss in the Sections 2, and 6.4.1.2, the last provision, which allows the use of addressable bridge switches to combat insertion noise as an equivalent solution, may preclude the use of some addressing schemes. This is an example of the need for thorough understanding of technical issues on the part of the cable authority.

#### **6.4.1.2 Addressability and access methods**

Addressability is needed to support pay-per-view television services, i.e., the subscriber interface must identify the user uniquely to the headend for program selection and billing. As was discussed in Chapter 2, the addressing scheme largely determines the flexibility and performance of communication services on the network; in particular, it determines who can speak to whom. Most cable operators are not immediately motivated to invest in addressing capabilities which will accommodate any-to-any communications because the market is as yet undeveloped. The cable authorities must evaluate the needs and desires of their community to establish the immediacy of demand, or potential demand, for such services; in so doing the authorities must be careful not to overextend the operator in an unproven market.

Many technical components of addressability can be added to the system on an incremental basis, i.e., interface units, headend software. But, there are other decisions regarding the cable plant that might prohibit implementation of particular access methods. For example, a contention channel cannot be implemented on a cable system that depends upon bridge switches to limit upstream noise. Contention channels must be continually open for

transmission and are incompatible with the on and off switching experienced on a branch of a network that uses bridger switches. Therefore, the provisions in the New Orleans franchise mentioned above may prove inadequate.

Multiple two-way access methods can be used simultaneously on a single cable system through the use of multiplexing techniques. But, given the small size of the existing market, initially there will be at most one data-communications based service, using a single access method, on each residential network. The city faces a choice between polling, hybrid, and contention access methods; the trade-off is limited function versus higher cost (see Chapter 2 for comparisons of access schemes). Institutional networks which are largely dedicated to communications services, as opposed to information services, can and will support many access methods simultaneously; the methods used will initially be determined according to the demands of large users.

#### **6.4.1.3 Reliability and maintainability**

The level of service, i.e., transmission performance and overall system availability (see Chapter 3) expected by business data communications users exceeds the level of service expected and delivered to subscribers on a typical residential network. Similarly, expectations of residents will increase as the residential services provided over the cable evolve from entertainment services to household business and other professional services. The cable operator should be sufficiently concerned about service presentation to make the necessary provisions because of the potential impact on market demand.

Reliability measures consist of built in redundancy and diagnostic capabilities, as well as security provisions for isolation and denial of service to malicious or malfunctioning units on the network. As with other factors mentioned, the longterm nature of the investment necessary to improve service might deter the operators from making the necessary provisions. In addition, as W. Baer notes, "...it is extremely difficult and expensive to 'add' reliability to a system at a later date." [8]. We do not suggest that the cable authority attempt to take on the task of designing the network for the operators. Rather, the authority should raise such issues and gather enough expertise to judge the responses of the cable operator.

#### 6.4.1.4 Communication services

The cable operator should have the capability and commitment to offer both communications and information services. On the institutional loop most operators do intend to offer communication services, and the facilities are being designed accordingly. Although subscriber-to-subscriber communications on the residential network may be premature for most communities, subscribers will desire communications with some parties other than the cable operator, e.g., banks, airlines, information services, educational and governmental agencies. The technical infrastructure necessary for communications services includes many-to-many addressability, i.e., higher level protocols to allow communication among subscribers and multiple service providers, in addition to two-way transmission (see Sections 2 and 2.1.2). Communication services require that the operator not involve itself with the content of communications; i.e., the operator behaves like a specialized common carrier.

As with the telephone system, institutional users will want the option of attaching privately owned equipment in addition to that leased from the cable operator, so long as it does not disrupt or damage the network. Cities should encourage the operator to offer many service types, not just private channels on the institutional network. This will allow small bursty users, who generally do not require private channels, to benefit from services, in addition to larger firms which generate enough traffic to justify leasing an entire channel. So long as the network is well engineered for data communications, specification of particular communications services can occur on an experimental and incremental basis.

#### 6.4.1.5 Interconnection

Institutional users will require interconnection with long-haul networks, while residential users will desire interconnection with neighboring cable networks. More than just physical linkage is necessary; higher level communication protocols must be established and implemented in order to allow effective services to develop. To this end the cable authorities should participate in standard-setting activities, to represent perceived community needs in what is today an industry-oriented process.

The number and type (over-the-air, local origination, data) of channels interconnected can be specified by the authority, leaving final decisions to the operators, in accordance with restrictions on content regulation (see Chapter 5). Interconnection of facilities (e.g.,

microwave links) and operational procedures can be implemented on an incremental basis so long as provisions are made for city input. The cable authority can also enforce a timeline and reserve the authority to review channel selection.

#### 6.4.2 Operational requirements

The application of cable networks to data communications requires more than upgrading the technical capabilities of the system. As discussed in Chapter 5, use of the cable for data communications applications blur the distinction between common carrier and broadcaster. Therefore, in establishing the regime for data, the cities must address structural and operational issues in order to ensure the best use of this medium.

##### 6.4.2.1 Leased Access

Leased access provisions have been included in many franchise contracts, but as with two-way requirements, their meaning is unclear without the mechanisms to implement them. In Section 5.3.5 we discussed the importance of leased access to the operation of data communication services via cable. Cable operators have shown considerable resistance to leased access provisions, but unlike resistance to other city demands, it is not primarily due to the financially burdensome nature of the request. Implementation of leased access channels entails minimal costs beyond the opportunity cost of other channel uses<sup>126</sup>. Given the abundance of channels on newer systems, this opportunity cost is not yet high, although as the demand for services grows, this opportunity cost will grow. Regardless of the opportunity cost, cable operators are wary of the inflexibility that leasing of channels implies.

The cable industry as a whole is concerned about the precedents set by leased channel access; namely, legitimizing programming control over a portion of the communication facility by a second party, and behaving in a manner which resembles a common carrier. "(T)he idea of first-come, first-served on a cable television plant, assuming that's what leasing means, is pretty distasteful"<sup>127</sup>. One multiple system operator, TCI, has a corporate policy not to offer

---

<sup>126</sup>The opportunity cost is equal to the revenues which could have been received had the channel been used for another purpose, such as pay-per-view services.

<sup>127</sup>Larry Howe, Vice President, ATC, a multiple system operator. Cited in *Cable Vision*; [52].



leased access, only to offer joint ventures. This is in support of their belief that, in accordance with first amendment rights, the operator should retain control over all programming on its facilities. Others in the industry feel that if leased access is rejected, the risk is greater that cable operators will be forced into common carrier status<sup>128</sup>. Still others in the industry consider leased access as an attractive source of revenue through leasing fees, and of increased subscriber penetration due to the enhanced services available.

In many cities, no one has yet requested to lease a channel. This situation will begin to change when data services are implemented. Data, seemingly more than video, lends itself to entrepreneurial endeavors; note the diversity of parties interested in videotex and teletext. This is partially attributable to the ability to target and charge users directly. To date, the newspaper industry has expressed the most interest in leased access. They are joined by security companies, other information providers, banking institutions, and local broadcasters. The American Newspaper Publishing Association (ANPA) reports that more than 60 newspapers have arrangements with local cable operators to program news and advertising services. Of these, 48 use one or two channels on a full-time basis. Joint ventures between the cable operator and the newspaper account for 13 of these, and leased access arrangements account for the remaining 35. Others operate on a local origination basis [52].

Implementation mechanisms for leased access have not yet been established. The following example of a leased access provision in the New Orleans franchise addresses the potential conflict-of-interest of the cable operator, but does not address pricing or technical mechanisms for its solution. (Note that as a concession to the cable operator, the franchise contract explicitly states that the provision of leased access by the operator shall not contribute to its being classified as a common carrier.) [20]:

Grantee shall offer leased channel service on the Home Subscriber Network to all residential and institutional subscribers at non-discriminatory rates and on reasonable terms and conditions. Grantee shall not use its position as a cable communications system operator to refuse leased channel service to any applicant who may wish to offer a service competitive with services offered by Grantee. Nothing contained herein shall be construed as requiring Grantee to operate as a common carrier nor shall Grantee be deemed to be engaged

---

<sup>128</sup> Stephen Effros, executive director, Community Antenna Television Association (CATA), cited in *CableVision*, [52]

in such operations.

In the recently settled Boston franchise, the local authority has attempted to eliminate this conflict of interest by giving control over operation of the leased access channels to an entity that is entirely separate from the cable operator, the Cable Television Access Coalition.

A number of difficult issues must be resolved in order to effectively implement leased access policies; in particular, we will address the following questions:

1. What should be included in a leased channel, i.e., which headend services?
2. What role should the cable authority play in the rate-setting process?
3. Should channels be priced on a cost or demand basis?
4. How long should the leasing period be?
5. How many channels should be leased?
6. How should demand be accommodated once it exceeds supply?

The authority and operator must identify which facilities are to be included in the leasing of a two-way channel; in particular, which head-end facilities are considered part of the leased channel services. On some systems, the channel will include only the frequency translation, and signal processing done at the headend. On other systems, switching and addressing capabilities, located at the headend, may be considered as part of two-way channel service. The decision should be based on which capabilities service providers need in order to effectively compete with the cable operator in providing a specific service.

The cable authority must address the setting and monitoring of rates to both residential subscribers and communication users. As was discussed in Section 5, structural regulation is ordinarily preferred to economic regulation; but, in the case of leased access, some monitoring of rates is necessary to ensure that the lessor does not discourage leasing of channel access by setting rates unreasonably high. The authority must first determine to what degree rates should be set, or to what degree "market forces" can be depended on to establish efficient rates which are close to cost. Because there is only one cable operator per community, competition is limited to that posed by alternative media. In the case of residential communication services, the competition is the local telephone company; in the institutional market, both the telephone company and DTS special carriers (see Section 4.2) are sources

of competition. The authority's decision should be based on the presence and strength of the competing media in their community. While various distribution media might be in operation, the comparison must be made between media that serve the same market. For instance, two-way video teleconferencing is not feasible over the existing telephone local-loop plant; nor over any of the alternative local distribution media currently in place; similarly, most of the alternative pay-television services (HBO, STV, etc.) will not compete in the pay-per-view or information services markets because they lack two-way capacity.

The goal in implementing leased access is to allow a diversity of information service providers access to the cable network in a manner that will allow them to compete on equal terms with the cable operator. Because the cable operator is itself an information service provider, i.e., complete separations are not enforced, provisions are needed to prevent this potential conflict of interest from distorting leasing charges, thereby discouraging access. Therefore, any pricing mechanism should strive for the following results:

- Competitive service providers are not discouraged from using the cable television network when it is the most technically appropriate medium available.
- Competitive service providers face the same costs in providing their services that the cable operator does in providing similar services.
- All service providers are treated fairly and equally.
- The cable operator does not extract excessive profits due to its monopoly power in the market. Excessive profits would unduly raise subscriber rates, and would inhibit demand and extension of network facilities.
- The pricing structure should establish economic signals that promote efficient use of scarce resources, such as upstream bandwidth on subsplit systems.

The pricing mechanism used to set leasing fees should be based on the premise that the cable operator is mandated to lease a specified number of channels<sup>129</sup>. This eliminates some of the incentive for the operator to set prices so high as to discourage competing service providers.

We briefly discuss two types of pricing mechanisms; the first is rate-of-return (ROR) and the

---

<sup>129</sup> In those instances where no leased access market develops over an extended period, the operator might be allowed to use the channels on a short-term basis.

second is open bidding. Extensive economic analysis and evaluation of pricing mechanisms for leased access channels is beyond the scope of this report. We believe that interim leased access policies can be implemented without thorough resolution of pricing issues; and if need be, that they should. But, in the long-term, as the markets for information and data communication services develop, the importance and complexity of the markets will make rigorous pricing mechanisms necessary.

Most parties, both operators and city authorities, agree that the complexities and inefficiencies of traditional rate of return regulation should be avoided (see Chapter 5). Nevertheless, the problem remains for operators to set leased access rates, and for authorities to monitor their fairness. Rate of return regulation applied to cable television leased access channels (not to the entire cable network) requires calculation of average variable costs, and of a fair figure for the percentage return. Cable television poses a unique problem for regulators that is not faced in telephone regulation; namely, the marginal cost function is not continuous. Marginal cost is close to zero when the channels are empty but it increases discontinuously, and significantly, when the channels are all occupied because the cost of installing additional facilities is large. Therefore, so long as there is additional capacity on existing facilities, marginal cost is low, reflecting low risk, and ROR pricing on the leased channels based on average cost allows the cable operator an equitable return on its facilities. In this instance ROR regulation succeeds in preventing the operator from exploiting its monopoly power by pricing access high above marginal cost; but, because the ROR price may be lower than the market clearing price, demand can exceed supply and some mechanism, such as a lottery, is needed to allocate the limited available spectrum. When all channels become occupied, marginal cost is suddenly greater than average cost, reflecting the high risk associated with installing new plant, and ROR regulation that requires the operator to accommodate additional demand at a price based on average cost, is no longer equitable. In addition, the marginal cost function for upstream and downstream access will differ on subsplit systems due to relatively scarce upstream capacity. In conclusion, ROR regulation for cable television leased access must take the discontinuity of the marginal cost function into account, which complicates an already difficult task. A bill which is under consideration by the Massachusetts State senate proposes ROR pricing for leased channels:

No charge shall be made for such leased capacity beyond the cost of the Operator of providing it, including an allocated share of support of public access, plus a reasonable rate of return.

Note that the Massachusetts Senate bill does not specify how this cost is to be determined, nor how construction costs for additional facilities are to be accounted for.

As an alternative to traditional ROR pricing, cable authorities might choose to mandate marginal cost pricing without actually engaging in rate of return regulation. In this way, if abuses are encountered, a basis for action will be in place. Members of the cable industry have proposed that if marginal cost is used as the basis for leasing fees, the cable operator should be paid a percent of gross or net revenues to account for the substantial capital investment made in the home. Others argue that price must reflect the opportunity cost of leasing the channel. The actual opportunity cost is difficult to determine; although one pay television channel may provide large revenue streams, it does not necessarily follow that an additional pay television channel will also return such high revenues. Alternatively, the opportunity cost could be equal to the revenues generated on the least-lucrative channel, since it is that channel that would be superseded by the new application. A complicating issue is that some channels are technically unsuitable for video, but can be used for data. These factors must be taken into account when calculating the opportunity cost of a channel.

Bidding, or auctioning, is a pricing method that does not depend on accurate estimation of cost, rather the charges should reflect market demand. Bidding can be implemented in a number of ways. For example, the operator can set an initial rate and service providers can bid the price up or down until all channels are leased. When the leasing period is over, both new and existing service providers bid for access, giving the existing service a chance to outbid newcomers and thereby protect its investment; this should prevent investment from being inhibited as a result of uncertainty posed by the leasing process. Charges for upstream access on residential subsplit systems should be higher than those for downstream access, to encourage efficient use of the relatively scarce upstream bandwidth.

Bidding does not require as much government intervention in the setting of rates. But, neither does bidding prevent the accrual of monopoly profits to the operator. Nor does it eliminate the relative advantage of the operator as a service provider; namely, the operator does not face the same access costs as do the other service providers. On the other hand, if the cable television medium is not in high demand, then the operator may be forced to lease access at a rate below average cost or marginal cost, and therefore below its own cost. In the long-term such a situation should not persist; if it does, then it refutes the need for leased access.

The competing service providers must base their bids on estimates of market demand for their respective services. These market demand estimates should take into account many factors: number of subscribers, penetration level, and the price elasticities for use of the cable medium by service providers<sup>130</sup>. There are very few information and data communication service providers in operation, which limits our ability to calculate the market elasticities. If these elasticities are underestimated then competing service providers will bid the leased access rates too high, resulting in excessive costs to service providers. These high costs would be passed on to subscribers and would result in excessive subscriber rates and suppressed market demand.

Despite the fact that bidding does not achieve some of the criteria listed above, it is a possible alternative to ROR regulation. Bidding has also been proposed as a method for leasing of satellite transponders.

There are difficult and important implementation questions which are common to all pricing schemes. These include the proper leasing time-period, and the handling of transitions from one leasor to the next, i.e., what happens to the customers of an information service if the service provider loses a renewal bid? Units of leasing for communication services must accommodate on-demand intermittent access, as well as dedicated circuit access. On-demand access is suited to a two part scheme with a fixed access fee and a usage sensitive fee based on packets, similar to toll pricing but with a different metric for usage. Leasing of channels on the residential network to information providers raises the question of contract length. The information provider and subscriber desire stability, while the cable operator typically desires flexibility: "The absolute longest period we like to consider these days is three years, we really like to look at a business plan for a local programming service that will pay us back in two years."<sup>131</sup> This comment reflects two somewhat separable concerns on the part of the cable operator: the length of the payback period, and the length of the commitment made to any single service. One resolution for the short-term is to allow the operator and service provider to decide these details, overseen by the cable authority to assure that community goals are being met and that any complaints on the part of service

---

<sup>130</sup> Price elasticity of demand is a measure of the effect that an increase or decrease in price has on demand, i.e., if demand is highly elastic then a small increase in price will lead to a proportionately large decrease in demand.

<sup>131</sup> Marty Lafferty, Cox Cable, cited in *Cablevision*, [52].

providers are addressed, via interim reviews and, if necessary, the courts. In the long-term, if demand for two-way capacity continues to exceed supply, then the cable operator will find it economically favorable to expand capacity. The reduced scarcity will reduce the uncertainty of service providers and subscribers. Eventually, the cable industry may become convinced that the information services market is sufficiently active to make complete separations acceptable.

In addition to the rate policies, the authority must determine the number of channels to be leased. Geller and Barron [27] propose the following channel assignment scheme<sup>132</sup>:

- 30-49 channel systems -- 5-10% of the channels
- 50-99 channel systems -- 15-20%.
- 100 or more channel systems -- 20-25%.

Subsplit, single-cable, two-way cable networks only accommodate four to five upstream television channels. But, a single television channel can be subdivided using frequency division multiplexing (FDM) to accommodate multiple leased access service providers (see Chapter 2). The authority must also establish procedures for accommodating demand when it grows to exceed supply. Traditional common carriers are required to add more facilities to meet demand. Unlike the telephone company, the quantum of growth is not one voice circuit, but an entire cable of 50 or more channels, i.e., the quantum of capacity and cost are large. Unlike electric utilities, there are no alternative service providers on which to off-load demand until a critical mass is reached which warrants new construction. In addition, the cost of new facilities can not be spread over ratepayers throughout the state, as is the case with other utilities. If cable operators are forced to accommodate new demand, they may discourage usage so as to forestall the capital investment in new plant. There must be pent up demand before the cable operator can, or should, justify investing in installation of additional cable facilities. One alternative to adding new cable is more intensive use of the existing spectrum. This would require upgrading of all modem equipment (although infeasible in residences, this could be feasible for institutional applications). For example, a contention access scheme which makes more efficient use of upstream bandwidth than does FDM might be used to subdivide a single upstream channel.

---

<sup>132</sup>The particular numbers chosen by Geller and Barron are somewhat arbitrary but reflect the belief that the very large systems will be less financially burdened by leased access requirements than will smaller systems.

A possible short-term strategy for cable authorities is to enforce a timeline for implementation and announcement of rates for leased access channels, but to withhold judgment on additional rate and access policies. The cable authority and the operator would agree upon interim review procedures whereby those market imperfections that might be evidenced during the specified experimental period could be rectified with appropriate pricing policies. During the experimental period, the cable authority could collect data on the rate levels, as well as the non-discriminatory, first come first serve access policies of the cable operator, for use during interim reviews. This strategy would avoid the uncertainty and burden of continuing intervention by the cable authority, while giving the operator the incentive to price access fairly enough so as to avoid rate regulation at the time of interim review.

#### 6.4.2.2 System expansion

Cities typically set provisions for assuring adaptation of new technology which becomes available, and economically feasible, during the term of the franchise. The following is an example of a "state-of-the-art" clause taken from a proposed bill before the Massachusetts state senate [40].

All CATV operators in the commonwealth shall make available, on each of their systems, any services that the same Operator makes available on any of its other systems, wherever situated, as such services become available from time to time.

It uses as its criteria for state-of-the-art, technology adopted by the operator on other systems. The assumption is that the operator will offer these new technologies only as is needed to compete with other operators in the course of franchise contests. This provision attempts to grant old franchises the same treatment as new franchises, thereby protecting the system from obsolescence. If these provisions are financially burdensome, operators might be discouraged from including new technologies on any networks; particularly once the cable franchising process is over and the competition with other operators for new business is reduced. The authorities should provide for interjection and review of community requests for new technologies during interim reviews of operator performance and rates.

As we discussed in Section 6.4.2.1 a particularly complex problem arises in regard to leased access. To what extent is the operator obligated to accommodate increased demand that exceeds its existing channel capacity? A procedure for detecting and reacting to this situation should be established. This procedure must detect when pent-up demand has reached a level



adequate to assure coverage of a fair portion of the new plant. At the same time, the city should discourage the cable operator from overextending itself as a result of mismanagement or overzealous external pressure.

#### **6.4.2.3 Separation of institutional and residential networks**

Some cities require that the institutional network be "provided, operated, and managed through a separate but affiliated corporation ... so that the costs and revenues of such service can be differentiated from those of the Home Subscriber Network" [20]. This arrangement can serve to protect against any cross subsidization between residential and institutional services which might otherwise occur due to differences in the elasticities of the respective market demands and franchise restrictions on residential subscriber rates. Other cities have taken this one step further by requiring that the institutional system be operated by the city as a municipal utility. No such systems are yet in operation, leaving us with little empirical evidence as to the relative merit of these approaches.

#### **6.4.2.4 Operator liability**

In preparation for extensive use of institutional network services, cable authorities must define the liability of the cable operator for providing a reliable (MTBF), maintainable (MTTR), and secure network to subscribers, information services, and communication users. Some customers will require and be willing to pay for more than others. This problem is not unique to cable networks and is not treated in depth here. For the most part, it is unlikely to be adequately addressed until services are in widespread use. The privacy and security problems discussed in Section 2.3.2.2 lead some to the conclusion that the cable network not be used for sensitive services that might be targets of maliciousness<sup>133</sup>.

#### **6.4.2.5 Privacy**

If and when residents and business users begin to mistrust the privacy protection offered by the cable facilities, it will be in the operator's interest to provide a high degree of privacy protection to maintain and encourage use of the cable facilities. Unfortunately, in the

---

<sup>133</sup>Saltzer, J., *Suburban Data Communications via CATV -- Preliminary Thoughts*, Working Paper, Laboratory for Computer Science, M.I.T., May 1981.

meantime, damage to individual privacy and the hardening of unsatisfactory practices can occur. Therefore, the cable authority should mandate some preventative practices, as well as provisions for future review by the city. Privacy provisions should include both protection of data stored in centralized facilities, and protection of communications transmitted over the cable. The privacy guidelines proposed by Warner-Amex exemplify a concern on the part of the cable industry (see Section 2.3.2.2); although these provisions do not include desirable restrictions on the storage of information in a form which can be traced to particular individuals.

Although adequate treatment of this subject is beyond the scope of this report, we hope to emphasize that it is a social and economic policy issue that deserves extensive public debate and research.

#### 6.4.3 State policies

Currently, only eleven states regulate cable. Consequently, cable policy is established primarily at the local level. As systems interconnect, jurisdiction will move into state and federal domains. State governments play a potentially important role in establishing state-wide guidelines and standards for cable networks installed and operated throughout the state. In addition, the state should officially grant local governments the authority needed to govern cable<sup>134</sup>. State governmental bodies should contribute technical expertise and resources, not available at the local level, to aid the municipalities. This could improve the quality of decision-making, pave the way for future system interconnection, and perhaps help to isolate cable policy from other local political issues which have no relevance to cable but which nevertheless impact decisions due to the dynamics of the local cable franchising process.

---

<sup>134</sup> It puts them in a stronger position and protects against the precedent of the Boulder decision.

## 6.5 Summary

We address local and state policy makers in emphasizing the importance of establishing a suitable infrastructure for two-way data communications. Because of its desirable applications and the need for advanced network planning, most cities should assign high priority to the data communications infrastructure which consists of both technical and operational requirements. Nevertheless, demands should be moderated by an understanding that increased demands in one area of system capability implies reduced demands in others, because of capital constraints, financial burden on subscribers, and negotiating strategies.

The cable authority must also decide to what extent it should, or must, participate in implementation specifications, beyond the level of general infrastructure. In making this decision, the cable authority should be aware of which capabilities must be incorporated into the initial cable design and which can be implemented in later stages, without incurring prohibitive costs. It should understand the costs and trade-offs and encourage the cable operators to make some compromises on near term cost minimization in return for longer term capabilities. But, at the same time, the authority must be prudent in its demands and avoid overextending the cable operators' resources.

The operational infrastructure for data communications primarily consists of structural regulations which will adequately separate the content and carriage functions combined in the cable operator. Leased access provisions, which set aside a portion of the cable network for operation on a common carrier basis, present an attractive alternative for reducing the conflict of interest posed by the cable operator's combined content and carriage functions. The pricing scheme applied to leased channels should be carefully selected to eliminate the incentives and ability of the cable operator to behave in an anti-competitive manner.

## Chapter Seven

### Conclusions

Cable television networks applied to data communications are unique and valuable municipal resource; but their utility will be determined by the diversity of services, and service providers, that are accommodated. Maximum utilization requires:

- A technical infrastructure that accommodates multiple servers and a variety of service characteristics.
- An operational infrastructure that ensures network access to a multiplicity of service providers and communication users.

The efforts of both the city cable authorities and the cable industry are necessary to construct these infrastructures.

#### 7.1 Network planning

The access scheme used will determine the future viability of the network for switched any-to-any communications. Currently, two-way communications on cable is conceived of in terms of polling for residential networks, and point-to-point FDM links for institutional networks. If cable is to fulfill its potential as a data communications medium, systems must be designed with the technical capabilities for implementing more flexible communications techniques such as contention, and CA-TDMA. Eventually, additional higher-level protocols will be needed to support interconnection of cable systems with each other and with other networks.

The noise and ingress on existing, as well as future, cable systems will be the largest technical hurdle faced in implementing two-way, quality data services. The use of bridger switches, while quite appropriate for a polling architecture, is not compatible with distributed networking schemes desired for city-wide business and residential communications. Therefore, other methods of reducing the noise on the upstream channel must be found. One seemingly appropriate method, is the use of digital regenerators, in parallel with some of the

return path amplifiers. In addition, aggressive maintenance procedures must be implemented. Ingress from interfering sources is greatly increased by leaky connectors. Most connectors must be tightened once or twice per year to insure proper fitting.

The high cost of installing cable will be overcome by the profitability of Pay TV services. Similarly, cable systems will be updated to meet franchise renewal requirements. In some areas new cable must be laid, in others, only two-way amplifiers modules need be installed, and the headend updated. All construction planning should take into account the relatively low marginal cost of adding excess capacity at the time of construction (either original or rebuilding construction) as compared to the high marginal cost of adding additional capacity after construction.

The proper architectures and media (e.g. cable vs telephone) for future transaction, videotex, and data communications services is irrevocably tied to the applications that develop. The use of wideband media could well be overkill for textual transaction services. Likewise, the use of phone lines is unacceptable for heavily used interactive image or facsimile services. Potential information service providers must make a thoughtful assessment of what is likely to be needed, demanded, and accepted in the next 5, 10, and 15 years.

## **7.2 Strategies for the cable industry**

The challenge facing the cable industry is to establish a communications infrastructure that will support a variety of information and data communication services, as well as entertainment services. Initially two-way communication capability between subscribers (or users) and the headend will be adequate. But, switched any-to-any communication will be needed to accommodate future growth.

In the long run, to be competitive, an information service must be deliverable over a multiplicity of communication media, since the availability of appropriate cable or telephone facilities will vary from city to city. Likewise, the communication services offered over the cable network must accommodate many services from a multiplicity of sources. *The cable industry should encourage the growth of other information service providers, since the success of all information services to the home and business rests on the existence of an*

information marketplace which is attractive in the aggregate. Because all services will be accessed via common interface and transmission facilities, they must be sufficiently attractive and varied to warrant the initial investment. To the same end of encouraging a multiplicity of services on the network, cable operators should encourage resident-to-resident communication applications. Person-to-person or interest group communications is the primary application of most existing computer networks, in particular the electronic bulletin boards used by hobbyist, i.e. personal computer owners. More market study is needed, but it is likely that there will be a market for such services among residents as well. Such services will place added pressure on the operator to show increased respect for the privacy aspects of cable communications.

In addition to in-house research and development efforts, the cable industry should encourage development of other pieces necessary to make data communication services economically viable; in particular, affordable home terminals and modem development. Some of the major cable component manufacturers are seeking joint ventures with established data communication firms to gain the much needed expertise in this field; examples are General Instruments and Sytek, and Scientific Atlanta and Amdax (see Appendix A). This is providing the cable industry with the technical workforce, and the data communication firms with the large amounts of capital necessary to produce equipment on the scale necessary for the cable television industry.

In both the residential and institutional markets the operator should offer multiple channel types -- broadcast, point-to-point, high speed, low speed, dedicated, bursty. In the institutional market, on-demand communication services should be offered in addition to dedicated private line service. On-demand service is suited to the intermittent nature of small business communications and promotes experimentation. Most importantly, the broadcast nature of cable network communications is suited to bursty mode packet communications; this feature gives it a competitive advantage over telephone local loop facilities. The tariff structures adopted by the cable operator should also accommodate intermittent users. That is, charges should be based on the data volume, not the connection time.

## 7.3 City policy

We address local and state policy makers in emphasizing the importance of establishing a suitable infrastructure for two-way data communications. Because of its desirable applications and the need for advanced network planning, most cities should assign high priority to the data communications infrastructure which consists of both technical and operational requirements. Nevertheless, demands should be moderated by an understanding that increased demands in one area of system capability implies reduced demands in others, because of capital constraints, financial burden on subscribers, and negotiating strategies.

The cable authority must also decide to what extent it should, or must, participate in implementation specifications, beyond the level of general infrastructure. In making this decision, the cable authority should be aware of which capabilities must be incorporated into the initial cable design and which can be implemented in later stages, without incurring prohibitive costs. It should understand the costs and trade-offs and encourage the cable operators to make some compromises on near term cost minimization in return for longer term capabilities. But, at the same time, the authority must be prudent in its demands and avoid overextending the cable operators' resources.

The operational infrastructure for data communications primarily consists of a structural regulations which will adequately separate the content and carriage functions combined in the cable operator. In a speech before the National Association of Telecommunications Officers and Advisors (NATOA) convention<sup>135</sup>, N. Miller described some possible abuses that might arise if this separation is not achieved:

...cross subsidizing the program costs from the facility's construction costs and revenues, ... price discriminating in favor of its own services when a competitor seeks to use the facility, or ... simply limiting the capacity of the system so no competing services can get on the system.

As a society we often hesitate to intervene in market operation as a means of directing technological development. But, in this instance, as in others, we must recognize that support of the status quo in itself will "determine" the development of cable television

---

<sup>135</sup>Miller, N., Speech to NATOA, October 23, 1981.

technologies and markets, as much as, if not more, than support of new structural regulations.

## **7.4 Suggestions for further research**

Further research in the following areas is requisite to the ability of cities and the industry to effect the infrastructures described above.

- Market research is needed to ensure cable operators of a financially secure environment in which to invest. This is particularly true of the residential market. This research must encompass developments in home terminals and information and transaction services. The cable network only comprises the communications medium that will link subscribers with each other and with service providers; without affordable home terminals, and attractive services, there will be no need for such a link. In addition, the nature of these services and terminals will determine the relative attractiveness of cable television as the communications link, versus the telephone local loop (e.g. the need for high bandwidth graphics). The traffic generated by this market will in turn determine the appropriateness of the various access schemes described.
- Experimental research is needed to rigorously characterize the technical limitations of upstream communications via existing cable television systems. Technical mechanisms for combating the problems and their related costs can then be evaluated and applied to decisions of rebuilding versus upgrading existing networks.
- Higher level protocol standards are needed to support effective and efficient networking. Development of adequate but not constricting protocols is necessary, along with general research into the standard-setting process.
- Sound leased access pricing mechanisms are needed that will accommodate growing demand, efficiently and with community interests satisfied.
- The potential for privacy abuse, which is intensified by the use of some computer and communications technologies, is a social and economic policy issue that deserves extensive public debate and research.
- City authorities and communities, along with responsible cable operators, must address methods for making these services and facilities available to the information poor, as well as the information rich. The potential educational value of the services, as well as opportunities for increased "technical literacy" to those households with access, will otherwise only serve to widen the gap between these two groups.



## Appendix A

### Provider Industry Structure:

#### Snapshot of the industry, January, 1982

The cable industry is currently an entertainment distribution and programming industry, not a communications industry. The provider industry for data services over cable comprises a number of participants: cable operators, cable and components manufacturers, modem manufacturers, LACN vendors, in addition to the information service providers who will be both customers and suppliers. What follows is a snapshot of the cable industry as it looked in January of 1982. Given the rapid changes in this field, the reader should regard this only as a representative sample, and should consult the trade press for more current information.

#### A.1 Customer Premises Equipment Companies

There are three types of firms that manufacture cable interface units: those that design cable converters for residential use, those that design FDM interface units for institutional markets, and those that design LACN interface units for private commercial networks. While the converter manufacturers have an advantage through their understanding of the residential market, the modem manufacturers have significantly more technical expertise in the field of data communications. The LACN manufacturers have the most sophisticated distributed data network expertise, but have no experience in the area of public networks, and residential services. The following discussion of the key players in these markets will exemplify the different approaches taken in addressing the residential and institutional two-way data communications markets.

## A.1.1 Converter Manufacturers

### A.1.1.1 E-Com

E-Com Corp.<sup>136</sup> manufactures both polled (TRU100, TRU500) and FDM (TRM202, TRM159) modems. The polled models operate over 0.250 Mhz, and 1.5 Mhz channels, and achieve data rates of 0.384 Mbps and 0.300 Mbps, respectively. The typical price is from \$50 to \$125 for residential terminals, and \$200 for commercial terminals. The FDM modems can accommodate both point to point and point to multipoint communications. They operate at 9.6 Kbps over a 100 KHz channel (0.096 bits/hz), and 1.5 Mbps over a 1.5 Mhz channel (1 bits/hz) at costs of \$750 per circuit end, and \$3000-\$6000 per circuit end, respectively.<sup>137</sup>

### A.1.1.2 Control-Com

Control-Com<sup>138</sup>, a subsidiary of Burnup and Sims Inc., has developed an advanced communications network based on cable technology, which they have implemented in private areas such as the Disneyland Hotel. Currently they are developing a two-way data system which will make extensive use of "area microprocessors" (intelligent bridge switches), which in addition to reducing the upstream channel noise, will perform network management functions.

The system will offer 9.6 Kbps service, with an aggregate data rate of 50 Mbps. The polling sequence to all area microprocessors will take less than 1 second. 80% of all upstream communications is expected to be home monitoring data which does not need to be communicated to the headend. Rather, the area microprocessor acts as a subnetwork headend which receives all monitoring signals from home units and only transmits those that require service to the headend. The effective upstream bit rate for each user is expected to be approximately 1 Kbps. More advanced network features can also make use of the area

---

<sup>136</sup>Information on E-Com systems is derived from a speech given by R.V.C. Dickenson, E-Com Corp., entitled, "Digital Data Transmission on CATV Systems", at the Canadian Cable Convention, 1977. The President of E-Com, Robert Dickenson, was one of the prime developers of the data services offered by MCTV.

<sup>137</sup>E-Com equipment brochure, available from E-Com, Stirling, N.J.

<sup>138</sup>Information on Control-Com developments is from Personal Communications with Jim Crocker on November 2, 1981.

microprocessor, for example jamming detection. Logic for the interface unit is implemented in a single custom chip.

#### A.1.1.3 Tocom

Tocom has over 10,000 units of subscriber equipment in use in the U.S. and Canada. They offer security, teletext, and interactive data retrieval using a polling access control scheme. The Tocom 55 Plus was delivered in June 1981<sup>139</sup>. The 5510A is a two-way home informational terminal adaptor which offers 55 teletext channels, in addition to interactive data retrieval, formatted screen data entry, and entertainment television. It costs \$250 in volumes of over 10,000. The 5510A uses a color graphics display with internal RAM. There is both vertical blanking interval (VBI) teletext, and full channel teletext.

The two-way interactive features include a built-in return transmitter which can communicate with the headend on up to three different return frequencies. The terminal supports opinion polling, subscriber response, pay-per-view, and channel monitoring. The system supports aggregate sampling via polling for collection of audience statistics, but does not allow individual monitoring, and does allow the user to disable the monitoring function.

Screen-formatting functions are supported for interactive transaction processing. Data entry is accomplished using formatted screens and a small keypad.

The 55 Plus system also includes headend facilities called the Programming Control System (PCS), \$155,000. It contains subscriber and programming data bases which can be maintained via operator consoles. The PCS communicates control information to the Headend Video Processors (HVP), \$3,000 per channel controlled. It also provides a return path for two-way communications. The HVP buffers and transmits the teletext data on the VBI. A Selective Data Retrieval processor operates the full channel teletext.

The Screen Composition System is used to enter the screen formats for subscribers. Communications with external computers for home information services, is supported via a processor which forwards external communications to the proper off-network site, and returns responses to the proper subscriber station.

---

<sup>139</sup>High Technology Group, "Interactive Technology Review for Cablevision's Boston Franchise Application", April 16, 1981.

#### **A.1.1.4 Pioneer**

Pioneer developed the hardware for the Warner-Amex Qube system. See Section A.2.1.1

#### **A.1.1.5 Jerrold**

Jerrold controls over half of the customer premises equipment (CPE) market for the cable industry. In addition to security, entertainment, and polling, Jerrold offers Communicom which is a two-way polling access communication system for pay-per-view and opinion polling applications. The modified converter costs \$195 which communicates with the headend via a security interface unit. Teletext is also offered. Activities in the field of two-way data have not been aggressive. This is likely to change with the recent investment in Sytek Inc, Jerrold's parent, General Instruments. The planned system is described in detail in Section A.1.3.1.

#### **A.1.1.6 Oak Industries**

Oak industries developed the interface unit used by Cox Cable for their Indax system (Section A.2.1.2 below).

#### **A.1.1.7 Scientific Atlanta**

Scientific Atlanta manufactures cable distribution plant components as well as cable converters. The newest Scientific Atlanta equipment announced requires a \$300 per mile upgrade to receive and transmit high speed data<sup>140</sup>. This data modem was developed by AMDAX Inc.<sup>141</sup> and will be exclusively marketed and manufactured for the cable industry via Scientific Atlanta.

---

<sup>140</sup> Cable Vision, December 21, 1981, pg. 133

<sup>141</sup> See Section A.1.3.2

## **A.1.2 Modem Manufacturers**

### **A.1.2.1 Mitre**

Mitre designed the network equipment for the first true broadband based local area network. Originally it was designed using a TDMA access scheme, and currently runs a contention scheme as well. The system runs on a dual 300 Mhz cable system where one cable was used for upstream and the other for downstream communications, exclusively. Mitre, a non-profit corporation, does not commercially sell its equipment, but does license its designs. Current licensees include Digital Communications Corporation, a subsidiary of MA/COM.

Although designed by Mitre private networks, the technology is now being adapted, by licensees of Mitre, to run on urban cable systems.

### **A.1.2.2 Local Data Distribution**

LDD<sup>142,143,144</sup> an affiliate of M/A-Com, has recently completed a joint experiment with Satellite Business Systems, and Tymnet, in local distribution over both cable and radio. The CARAVAN<sup>145</sup> involved two-way data communication over the institutional cable facilities of MCTV in Manhattan and Viacom Cablevision in San Francisco. As of December, 1981 there were two cable subscriber stations in San Francisco at an average distance from the headend of 10 miles. The MCTV cable system in New York had six subscriber stations.

The cable headend transmits all downstream data in a TDM fashion to all subscribers in the high frequency band. Subscribers respond using a TDMA technique in the low frequency band. The headend is linked point-to-point over the cable to a satellite earth station for long haul traffic. The system uses a 1.5 Mhz channel for 1.8 Mbps aggregate data rate (1.2

---

<sup>142</sup>Richmond, R.L., Digital Communications Corporation, "Recent Advancements in Local Data Distribution", Working Paper available from DCC, Germantown, Md.

<sup>143</sup>"SBS, TYMNET, LDD CO. Report Success in Local-Loop Demonstration Program", Press Release No. 81-39, Tuesday, November 24, 1981.

<sup>144</sup>Swinton, W., Tymnet, Inc., "CARAVAN: Experiment in Wideband Local Digital Data Distribution", National Telecommunications Conference, 1981.

<sup>145</sup>Cable And Radio Architecture for Value-Added Networks.

bits/hz). Channel allocation and switching providing full connectivity are implemented at the headend. The cable equipment used is approximately 30% lower in cost than the microwave radio facilities which were also part of the experiment.

Digital Communications Corporation, another subsidiary of M/A-Com, and the designer of the modems used by LDD, has installed a system in the Las Colinas, 12,000 acre, master planned community in Irving, Texas<sup>146</sup>. The system operates on an underground triple trunk, one subsplit, and two midsplit. It is configured in a single hub and is currently being upgraded to provide dual distribution 400 Mhz capability throughout the system. The services planned for the network include residential videotex, as well as business data communications of varying grades for small, medium, and large businesses. All services will be based on the DCC TDMA technology, with some additional polling equipment as well. Transmission speeds will be as high as 1.544 MBps, and will offer full connectivity between subscribers.

#### **A.1.3 Local Area Computer Network Vendors**

The past three years have witnessed the development of a new, and still very small, industry of LACN vendors. These companies design networking equipment for diverse digital devices and computers which are spread over a contained area such as an office building. The state of the art distributed network products do not come from the manufacturers who have long been making modems for industrial cable networks but from this crop of new companies, growing out of the mini- and micro-processor industry.

Both the industrial modem manufacturers and the LACN vendors are gearing up for producing high speed data interface units for intra-city communications. FDM and Polling equipment is widely available, while contention and TDMA equipment is still largely in the experimental or design stages.

##### **A.1.3.1 Sytek and General Instruments**

Sytek and General Instruments are jointly developing an advanced data communications

---

<sup>146</sup>D. Silverman, P. Freedenberg, D. Schoen, "Architecture Analysis for the Las Colinas Association Communications Network", EASCON '81, Washington D.C., November, 1981.

system for cable called Metronet<sup>147</sup>. Sytek is a communications consulting firm which has a growing line of broadband based LACN products on the market. The LACN is called LocalNet and uses a contention, CSMA-CD, access scheme. LocalNet20 runs at 0.020 Mbps, and LocalNet40 runs at 2 Mbps (0.33 bits/hz). General Instruments recently invested heavily in Sytek. General Instruments, through its Jerrold subsidiary, has extensive experience in the cable industry: Jerrold controls over half of the cable customer interface unit, and distribution electronics markets. The cumulative installed terminal base through the end of 1980 was 11,850,000, 52% of which were General Instruments products<sup>148</sup>.

Sytek, where the R&D activity for Metronet is centered, is still in the early planning stages but they have set out requirements and a general architecture for Metronet with impressive foresight. For this reason, the details of the Sytek design philosophy are outlined below.

Sytek has designed Metronet under the following assumptions:

- Concentration on *data* traffic.
- Equipment should operate on **Subsplit systems, operating at 25 Mhz in each direction (4 upstream and 4 downstream channels of 6 Mhz each.)**
- Primarily small business and residential customers.
- Bandwidth should be assumed to be scarce.
- The network should be designed to **withstand hostile environments.**
- User interfaces should be IEEE 802<sup>149</sup> compatible. The network itself is not designed to follow any standard.

The Network Requirements are defined as follows:

- Large subscriber capacity -- 50,000 to 200,000.
- Adequate expansion for 10 years, without any increase in bandwidth.

---

<sup>147</sup> Information about Metronet is derived from personal communications with Robert MacNamara of Sytek, on November, 1, 1981. Metronet is strictly in the planning and design stages and is not an announced product or offering.

<sup>148</sup> "Record Levels", *Cablevision*, November 2, 1981

<sup>149</sup> IEEE 802 is the draft local area network standard.

- Adaptability to new services.
- Non-disruptive expansion.
- Packet switched, with a maximum access time greater than 100 ms., no more than 1% of the time.
- Geographical extent less than 40 to 50 miles<sup>150</sup>.
- Residential network would use primarily CSMA-CD.<sup>151</sup>
- Connectivity of any two subscriber nodes.
- Point-to-point, full duplex, connectionless service.
- Support up to 20 Kbps per node.
- Off-network nodes with proper interfaces to serve as gateways to SBS, public switched networks, etc.
- Control requirements:
  - \* Grant or denial of transport service access to any node.
  - \* Identification of source and destination node for each session<sup>152</sup>.
  - \* Control of illegal use of access and bandwidth.
  - \* Protection from physical attack -- vandalism (detection, isolation, and repair); Theft (detection, denial, and enforcement); privacy.
  - \* Administration to adjust traffic load.
- Pricing, flat rate per access or per packet.
- Diagnostics -- Check channel and equipment; Time-outs.

Network services will include caller and callee charging options, polled service access, and

<sup>150</sup> As was discussed in Chapter 2, contention access protocols such as that proposed by Sytek, presents a trade-off among distance, data rate, and packet length; therefore, the exact distance specification will depend upon the data rate used.

<sup>151</sup> Sytek's bias towards this technology should be kept in mind because of their established expertise in the area.

<sup>152</sup> This capability will carry with it the possible need to regulate the use of this data, as with the telephone company.



videotex using the AT&T Presentation Level Protocol (PLP). Value added services will include translation, speed buffering, and key distribution. Sytek believes that most of the information will not be considered worth encrypting with the obvious exception of banking services.

The network architecture will be based on a distributed intelligence approach, in line with the LocalNet architecture, with some exceptions. Because the network will not be owned, used, and operated by a single organization, as is the case with most LACN's, the network will have some centralized control of communications, to realize the network monitoring and management necessary.

Virtual circuit initiation will occur on a per session basis. Each node will have a hard wired node ID, and a commonly known node address. The headend will establish network authenticity through use of these keys, upon receipt of out of band requests for virtual circuit establishment.

The 25Mhz will be divided into 100 channels each supporting a data rate of 0.1 Mbps (0.4 bits/hz). Each node is assigned a home channel. When a session is requested the headend will verify the authenticity of the source and destination, check traffic loading, and then signal the source to switch to the destination node's home channel, assuming it is free. After the destination is notified, the headend Data Channel Access Monitor (DCAM) will exit the process. If any channel becomes unusable, the DCAM will reinitialize the communications on another channel. The projected cost is \$50,000 for the headend. This is almost 20 times the unit price of the LocalNet headend.

The expected usage traffic is 1,000 to 2,000 simultaneous sessions per channel with 60 Kbps throughput at peak load.

A terminal with sophisticated graphics capability will be sold by Jerrold. It will be based on a Motorola 68,000 microprocessor, and 1/4 to 1/2 Mbyte of memory. When the market grows large enough to warrant a VLSI version, the price could drop to \$200<sup>153</sup>. Sytek feels it is necessary that the cost per node be kept in the \$200 range, which is how much addressable video converters currently cost. Sytek would like to keep the monthly network fee in the \$20

---

<sup>153</sup>No estimate was given for current, LSI versions but similar devices such as the Radio Shack TRS/80 sell for \$4,000.

range. Given 10 channels with 1,000 subscribers per channel, the system should be able to accommodate a 15 minute session per average residential subscriber per day.

Sytek is still establishing its plans for an institutional network. Currently the targeted customer base is leased lines users. Sytek feels that the institutional market will evolve into transport services between LACN sites, or as last mile transports to long-haul networks, i.e. private lines. In addition, they feel that the cable network could end up being used primarily as an alternative voice medium. For the institutional market, both TDMA and CSMA-CD are possibilities for the access scheme.

It is clear that Sytek is designing a communications system intended for the use of multiple "servers", and not a video entertainment, or videotex network with a single server, as is the current model.

#### A.1.3.2 Amdax

Amdax supplies much of the point-to-point FDM interface equipment for MCTV. These interface units are used in their first private LACN product which implements a switched FDM access scheme. More recently, Amdax has announced Cablenet, which uses a DA-TDMA access scheme for campus and plant-wide LACN's. They propose to extend their products onto cable systems and have signed an exclusive manufacturing and marketing contract with Scientific Atlanta for sales to the cable industry.

#### A.1.3.3 Wang

Wang's LACN, Wangnet, uses FDM to divide 350 Mhz of bandwidth into three independent bands:

1. Interconnect band -- many point-to-point channels using FDM at data rates up to 64 Kbps (frequency fixed modem, \$1,250), and 9.6 Kbps (frequency agile modem, \$1,250).
2. Wangband -- a 12 Mbps contention channel which runs over 18 Mhz (0.667 bits/hz, \$3,000).
3. Utility band -- for surveillance, instrumentation, or teleconferencing.

Wang uses two cables, one for upstream transmission and one for downstream. It covers areas up to 10 miles in diameter.

#### **A.1.3.4 Interactive Systems/3M**

IS/3M has sold broadband communication systems since 1974. Their systems are intended for use as private LACN's but are applicable to urban cable networks. Their systems are of two types, TDM and switched FDM. Low speed FDM modems for both point-to-point and multipoint applications offer data rates from 600 bps to 9600 bps, and medium speed modems from 1200 bps to 96kbps. IS/3M also designs and manufactures higher speed modems for OEM applications. Many LACN and private firms buy rf-modem hardware from IS/3M for use in LACN's with more complex communication protocols. 3M has recently announced a 1.5 Mbps rf-modem for \$400.

### **A.2 Services**

#### **A.2.1 Cable Operators**

Currently over half of all cable networks are owned by small companies. Systems in the larger cities are increasingly being consolidated under the operation of a few big firms called Multiple System Operators (MSO's). This consolidation process is likely to continue and speed up over the next 5 years, as more of the old franchises come up for renewal. At that time it will be increasingly difficult for the small operators to compete with the offerings of the large, wealthy, MSO's. The large MSO's will offer to retrofit the systems for two-way capability, or to rewire if necessary, and thereby win the franchise renewal.

##### **A.2.1.1 Warner-Amex**

Warner-Amex, jointly owned and operated by Warner Bros Communications and American Express, offers an interactive cable service called QUBE, based on a polling access protocol. The system has 32,000 subscribers and the cable passes 100,000 homes<sup>154</sup>. Qube was the first interactive two-way residential cable network and, even today, has few competitors.

The headend computer is made up of three Data General Eclipse S-200's (16-bit multiprocessor minicomputers with 256Kbytes of main storage). The system offers three interactive services: response polling, security monitoring, and pay-per-view television billing.

---

<sup>154</sup> Cablevision, October 12, 1981, "Qube Under Fire.", pg 73.

The Qube system relies heavily on the use of bridger switches to control the impact of insertion noise on the upstream channels. This method is compatible with the polling access scheme used. Qube developed this technique which has since been implemented in other two-way cable installations.

All subscribers have addressable terminals with 4-bit microprocessors. Three to four times a minute the terminal is polled by "name". The terminal responds to a few commands: status (on/off), channel number, last response button pressed on keyboard, and OK for security monitoring. The interactive terminal is called a BT1300 and transmits and receives at 0.256 Mbps. It costs from \$245 to \$465, in quantities over 30,000, but is expected to drop to \$200. Packets of 1K to 2K bits are permitted.

The price to the subscriber of the premium channel, which includes full polling capabilities, is approximately \$15 installation and \$4 monthly.

#### A.2.1.2 COX Cable

Cox<sup>155</sup> is operating an experimental system called Indax (Interactive Data Exchange) in San Diego, California. Additional systems are being installed in Atlanta, New Orleans, Omaha, and Tucson. The Indax system is one of a few two-way, fully interactive videotex systems designed for cable. The network will operate 60 0.056 Mbps<sup>156</sup> data channels, using 0.3 Mhz spacings (three, 6 Mhz channels; 0.186 bits/hz). The downstream channels will operate at 15 to 17 dB below the video carrier power, which allow them to be run on three lower channels which are not normally used for video because of interference in these bands. The upstream channels will operate between 5 and 30 Mhz. The uncorrected bit error rate is specified at  $10^{-8}$ , and the corrected BER (with cyclical redundancy checking, and retry) at  $10^{-12}$ .

Cox uses a fully redundant Tandem Computer for headend control. The estimated per subscriber share of the headend fixed costs is \$75. The traffic capacity of the system was estimated, using a simple model, to accommodate an average of 16, 15-minute sessions per

---

<sup>155</sup>Information on the Cox system was taken from a speech by Gary Tieden of Cox Cable, on March 19, 1981 at a M.I.T. Communication Seminar on Home Information Systems, as well as from personal communications on October 14, 1981.

<sup>156</sup>Some of the Indax systems will operate at 0.028 Mbps, such as that being installed in New Orleans, La.

month per subscriber. It is expected that 90% of the data will travel downstream, and the remaining 10% upstream. The Tandem is expected to handle one transaction every two seconds. Accounting for a 4-hour busy hour, and a peaking condition of 6% of the users at any one time, it was calculated that the system could have available for viewing approximately 5,000 one-way pages. This is considerably more pages than either phone-based videotex, or teletext systems can provide with the same response time.

The home terminals are microprocessor driven and are therefore fairly expensive. Estimated costs are \$320 dollars per subscriber terminal with data communication capabilities, and \$120 for two-way capabilities without data. The data channels are accessed with the contention protocol, CSMA-CD. Using this method, it is assumed that channels can be run at 85% efficiency. Approximately 15,000 could be served on a 16 processor Tandem system, and 100,000 on a system with 10 data channel pairs. The two-way interface units are being supplied by Oak Communications.

In total, Cox estimates that it will cost approximately \$250 per subscriber to offer two-way Indax services. A base cost for a two-way addressable 54-channel cable system is \$500 per subscriber, placing Cox's total system costs at approximately \$750 per subscriber.

Cox will offer a variety of services, including Electronic Banking and Shopping. The software is being developed by HomeServe, a division of American Can. The cable operator will in turn act as a carrier between the subscribers and the service provider, who will act as an interface to the subscribers' banks. Shopping services and a "commercials" channel are proposed as well.

Information data bases are connected to the headend via X.25 lines. Information which is frequently accessed, such as the UPI news data base, are stored at the headend.

In addition to a residential Indax system, Cox is installing a 20 mile dual cable midsplit institutional network in New Orleans, as part of the franchise agreement. The communications service on the institutional network will be owned and operated by a separate affiliate of Cox, Comline. It is not yet determined what services will be offered at this time, although some point-to-point high speed data communications and teleconferencing will be included. The suggested tariffs range from \$37 for 1.2 Kbps to \$1000 per month for over 19.2 Kbps service.

#### **A.2.1.3 Times Inc. -- Manhattan Cable**

MCTV offers the only non-experimental data communication service via cable, and has been doing so since 1975. MCTV is a wholly owned subsidiary of Time, Inc., one of the largest MSO's in the U.S. MCTV currently services four major banks in Manhattan at data rates up to 1.544 Mbps on a dedicated cable that runs the 5 miles between Manhattan's downtown and midtown financial centers. The links are strictly FDM, and are offered as a leased-line alternative.

MCTV guarantees maximum down-time of 18 seconds per day<sup>157</sup> and a bit error rate no worse than 1 in  $10^7$ . The downstream channels are operated from 160 to 360 Mhz; with 5 to 110 Mhz used upstream. Standard data rates are 2.4 Kbps, 4.8 Kbps, 9.6 Kbps, 19.2 Kbps, 0.056 Mbps, and 1.554 Mbps.

The monthly lease rates range from \$220 per month for a 0.0024 Mbps line to \$1000 for a 1.544 Mbps line<sup>158</sup>. Installation charges are \$150 to \$200 per end, depending upon the data rate. If the site is not near the trunk cable, construction may be needed to reach the building with additional drop cable. These construction costs could prove prohibitive.<sup>159</sup>

#### **A.2.1.4 Rogers Cablesystems**

Rogers Cablesystems<sup>160</sup> is currently developing a packet data network for upstream carriage of videotex and home computer communications services to the home. Trials are being run in Oregon, and are scheduled for a Minnesota system as well. Rogers plans to serve 10,000 per network, using a 8 Mhz frequency allocation, for a data rate of at least 1 Mbps. Rogers will also operate over a previously unused part of the lower video spectrum.

Minnesota Cablesystems Southwest (CSW) is a 400 Mhz system which will service over 56,000

---

<sup>157</sup>This is equivalent to 99.96% network availability.

<sup>158</sup>MCTV, Manhattan Cable Communication System, Monthly Lease Rates, June 1, 1980

<sup>159</sup>International Resource Development Inc., "Local Networks and Short Range Communications", Report # 158, October 1980

<sup>160</sup>Information on the Rogers System is derived from a speech by T. Chislett of Rogers Cablesystems entitled, "Enhanced Two-Way Residential Systems", presented at EASCON, November 18, 1981.

homes, on over 700 miles of plant in 5 cities. A separate 166 mile institutional and business network will serve telecommunication users. Telidon services will be available, with up to 10,000 pages accessible. Rogers will offer both in-home, and "shared" Telidon terminals.

The radial hub configured 400 Mhz system uses "intelligent" bridger amplifiers. The code operated switches at each of the trunk amplifiers, gates the upstream transmission of that trunk which is in the 5 to 12 Mhz band. The central computer continually scans the switches. An entire system scan takes a total of 6 seconds.

The business network will interconnect educational, governmental, medical, and business institutions over a separate radial trunk system. Interconnection with Telenet via the headend is planned. Rogers expects the institutional network "to become the high-speed local loop for various satellite carriers wishing to service customers in the area without the penalty of very expensive land lines or installation of earth stations at each location."

#### A.2.1.5 Sammons Communications

Sammons Communications has an operating information retrieval service via cable in Highland Park and University Park, Texas, a Dallas suburb<sup>161</sup>. There are approximately 12,000 homes in this area and a large percentage of high income executives.

The system is a 35 channel 300 Mhz subsplit system which began operation in December, 1979. All services are on a polled basis with 56 Kbps downstream data rate, and 28 Kbps upstream. The system is expected to handle 280 customers per second. Currently the services offered consist of professional data bases offered through Dow Jones, in Princeton, New Jersey, and Belo Information Service, which is a consumer oriented local service. It is expected that most national information services in the near future will be offered through Dow Jones, although it is possible to connect directly to the system's headend. All communications with the headend are currently via 9600 baud telephone lines. In addition the upstream requests are accepted both via the upstream cable channel and via the telephone. The hardware is provided by Tocom.<sup>162</sup>

---

<sup>161</sup>J. Caddy, "Active Information Retrieval in CATV", EASCON '81, Washington, D.C., November, 1981.

<sup>162</sup>Section A.1.1.3

### **A.2.2 Transaction Service Providers**

The banking, catalog shopping, and travel industries are interested in cable as a medium for transaction services for consumers. In addition the banks see cable institutional networks as a medium for communication with commercial clients in downtown centers.

In the long run banks are unlikely to turn over control of residential service offerings to the cable operator. In the short run, joint ventures are proceeding between banks and "software houses" such as Homserve. Those industries interested in the transaction market will feel compelled to enter into these ventures as a way of testing and promoting the market. Homserve and Bank One are currently developing an experimental system to be run over the Cox Cable Indax system.

### **A.2.3 Information Service Providers**

Information service providers currently consist of a select number of banking institutions and professional data base services. In the future, they will be joined by advertising firms and retailers, among others.

In addition there are the professional data bases such as Nexis, Lexis, Dialog, etc. These firms will benefit from the increase in outlets for their information, and will play an active role in encouraging such development.

Much has been written about the videotex services offered in other parts of the world, most notably, Prestel in the U.K., Antelope in France, and Telenor in Canada. In all three cases the services use a centrally organized and controlled data base. The data base facilities are made available to information providers on a "common carrier", first come, first serve, basis and is operated by the PTT. The U.S. has no PTT, but AT&T has proposed a videotex standard, PLP which it would like to offer over the telephone network (a hybrid network is also being considered). AT&T is restricted from content oriented functions such as information provision.



#### **A.2.4 Communication Service Providers**

Telenet, Tymnet, Graphnet, SBS, and MCI all have a stake in the "last mile bottleneck". At the same time that their services will be greatly enhanced by an improved delivery medium, they might also find the cable companies alternative digital communication networks offering competitive value added services.

## **Appendix B**

### **Glossary of mnemonics**

**ACM** -- Association for Computing Machinery

**BER** -- Bit error rate. A measure of transmission reliability, the number of bits incorrectly transmitted.

**CATV** -- Community antenna television. The original name for cable television.

**CSDC** -- Circuit switched digital capability. A new capability proposed by the telephone company for digital transmission over existing local loop facilities, see Chapter 4.

**CSMA, CSMA-CD** -- Carrier sense multiple access, and carrier sense multiple access with collision detection. A contention access protocol for sharing a single communications channel among many users, see Chapter 2.

**DAV** -- Data above voice. A technique for transmitting digital data signals in the frequency spectrum above analog voice signals over local loop facilities, see Chapter 4.

**DTS** -- Digital termination service. A local distribution technique using digital microwave, see Chapter 4.

**FCC** -- Federal Communications Commission

**FDM** -- Frequency division multiplexing. A means of obtaining a number of smaller channels from a given frequency range by dividing the larger channel in frequency.

**IEEE** -- Institute of Electrical and Electronics Engineers

**LACN** -- Local area computer network. A communications network for devices within a campus-sized area.

**LADT** -- Local area data transport. A name used by the phone company to describe services based upon DAV, see above and Chapter 4.

**MSO** -- Multiple system operator. A cable operator that owns multiple systems.

**MTBF** -- Mean time between failure. The mean time between failures of a system component.

**MTTR** -- Mean time to repair. The mean time between failure of a component and repair.

**NATOA** -- National Association of Telecommunications Officers and Advisors

**NCTA** -- National Cable Television Association

**NTIA** -- National Telecommunications and Information Agency

**PSTN** -- Public switched telephone network. Traditional telephone network.

**TCM** -- Time compression multiplexing. The transmission method used to implement CSDC, see above and Chapter 4.

**TDM** -- Time division multiplexing. A means of obtaining a number of channels over a single frequency range by dividing the channel in time.

**TDMA** -- Time division multiple access. A means of sharing a channel among many users by allocating different time-slots to different users.

## References

See Appendix B for explanation of abbreviations.

- [1] Abramson, N.  
**The Throughput of Packet Broadcasting Channels.**  
*IEEE Transactions on Communications* 25(1):117-128, January, 1977.
- [2] Ahamed, S., Bohn, P., Gottfried, N.  
**A Tutorial on Two-Wire Digital Transmission in the Loop Plant.**  
*IEEE Transactions on Communications* 29(11):1554-1564, November, 1981.
- [3] Akgun, M.  
**Comparison of Technology and Capital Costs for New Home Services.**  
*IEEE Transactions on Cable Television* 5(3):1-15, July, 1980.
- [4] Allora-Abbondi, G.  
**Transmission System Evaluation for Two-Way Cable.**  
*IEEE Transactions on Cable Television* 4(3):111-118, July, 1979.
- [5] Arnold, B.  
**Third Order Intermodulation Products In A CATV System.**  
*IEEE Transactions on Cable Television* 2(2):67-80, April, 1977.
- [6] Auerbach, L.  
**The distinction between carriage and content.**  
*Telecommunications Policy* 5(1):3-11, March, 1981.
- [7] Averch, H., Johnson, L.  
**Behavior of the Firm Under Regulatory Constraint.**  
*American Economic Review* 52(5):1052, 1962.
- [8] Baer, W., Botein, M., Johnson, L., Pilnick, C., Price, M., Yin, R.  
**Cable Television: Franchising Considerations.**  
Crane, Russak and Company, Inc., New York, 1974.
- [9] Baldwin, T., Muth, T., Saxton, J.  
**Public policy in two-way cable.**  
*Telecommunications Policy* 3(2):126-133, June, 1979.

- [10] Baran, P.  
Broad-Band Interactive Communication Services to the Home: Part I -- Potential Market Demand.  
*IEEE Transactions on Communications* 23(1):5-14, January, 1975.
- [11] Biba, K.  
LocalNet: a digital communications network for broadband coaxial cable.  
In *21st IEEE Computer Society International Conference (Comcon '81 Spring)*, San Francisco. March, 1981.
- [12] Bux, W.  
Local Area Subnetworks: A performance comparison.  
In *Proceedings of the IFIP Working Group 6.4 International Workshop on Local Networks, organized by IBM, Zurich, Switzerland, August 27-29, 1980*.  
Edited by West, A., and Jahson, P.; published by North-Holland Publishing Company, New York
- [13] *Cable Television, Government Regulation, and the First Amendment*.  
NCTA, 1981.  
Report to Senator Packwood; available from the NCTA, Washington, D.C.
- [14] Cable Television Report and Order.  
February 1972, 36 FCC 2d 143
- [15] CABLEFILE/81.  
Titsch Publishing, Denver, CO
- [16] Assemblymen Robinson, Bosco, Kapiloff, Waters.  
Cable Communications Act of 1982.  
AB2742, April 14, 1982; California State Legislature
- [17] Campbell, J., Thomas, H.  
The Videotex Marketplace.  
*Telecommunications Policy* 5(2):111-120, June, 1981.
- [18] Charter, J., Hatfield, D., Salaman, R.  
*Local Distribution--The Next Frontier*.  
Technical Report, National Telecommunications and Information Agency, April, 1981.

- [19] U.S. Congress. House. Committee on International and Foreign Commerce.  
Subcommittee on Communications.  
*Cable Television: Promise Versus Regulatory Performance.*  
U.S. Government Printing Office, Washington, D.C., 1976.
- [20] *Ordinance Granting a Franchise to Cox Cable.*  
City of New Orleans, Louisiana, 1981.
- [21] Dickenson, R.  
Digital Data Transmission on CATV Systems.  
Presented at: Canadian Cable Convention, 1977
- [22] Dineson, M., Picazzo, J.  
Broadband technology magnifies local networking capability.  
*Data Communications* 9(12):61-79, February, 1980.
- [23] *The Ethernet, a Local Area Network: Data Link Layer and Physical Layer Specifications, Version 1.0.*  
Xerox Corp., Palo Alto, Calif., Intel Corp., Sunnyvale, Calif., and Digital Equipment Corp., Tewksbury, Mass., 1980.
- [24] Federal Communications Commission v. National Citizens Committee for Broadcasting, et al.  
January 1978, 436 US 775
- [25] Federal Communications Commission v. Midwest Video Corporation et al.  
April 1979, 440 US 689
- [26] Frisch, I.  
Experiments on Random Access Data Transmission on Coaxial Cable Video Transmission Systems.  
*IEEE Transactions on Communications* 25(10):1199-1203, October, 1977.
- [27] Geller, H., Barron, Ira.  
Petition to the FCC in the Matter of Cable Leased Access on the New, Large Capacity Systems.  
October 1981

- [28] Goldstone, P.  
Legislation aimed at cable.  
*CableVision* 7(27):13, March 15, 1982.
- [29] General Telephone Company of the Southwest et al, v. Federal Communications Commission.  
September 1971, 449 FR 2d 846
- [30] *Interactive Technology Review for Cablevision's Boston Franchise.*  
High Technology Group, Danen, Connecticut, 1981.  
Available at the Massachusetts State Cable Office, Boston, Massachusetts.
- [31] Walter, G., DiYanni, S.  
Reply Comments of International Business Machines Corporation on Petition to the FCC in the Matter of Cable Leased Access on the New, Large Capacity Systems.  
January 1982
- [32] *IEEE 802 Local Network Standard, Draft B: A status report.*  
IEEE Computer Society, Silver Spring, MD., 1981.
- [33] Jacobson, R.  
*Municipal Control of Cable Communications.*  
Praeger Publishers, New York, 1977.
- [34] Jeffers, M.  
Technical Considerations for Operating Systems Expanded to Fifty or More Television Channels.  
*IEEE Transactions on Cable Television* 5(1):2-5, January, 1980.
- [35] Jones, W., Riter, S., Hambrick, R.  
Telecommunications in Urban Public Services.  
*IEEE Transactions on Communications* 23(1):15-19, January, 1975.
- [36] Kent, S.  
Security Requirements and Protocols for a Broadcast Scenario.  
*IEEE Transactions on Communications* 29(6):778-786, June, 1981.

- [37] Levy, W., Rothberg, M.  
Coaxial cable finds a home.  
*Mini-Micro Systems* 14(3):99-108, March, 1981.
- [38] Levy, W.  
Wangnet: a bold step forward?  
*Mini-Micro Systems* 14(11):247-254, November, 1981.
- [39] Martin, J.  
*Telecommunications and the Computer, Second Edition*  
Prentice-Hall, Engelwood Cliffs, New Jersey, 1976.
- [40] Massachusetts Senate Bill No. 370.  
An act to provide for public access to community antenna television systems and to protect the privacy of individual users, January 1982
- [41] Metcalfe, R., Boggs, D.  
Ethernet: Distributed Packet Switching for Local Computer Networks.  
*Communications of the ACM* 19(7):395-404, July, 1976.
- [42] Michell, M.  
*State Regulation of Cable Television.*  
Technical Report, Rand Corporation, October, 1971.  
R-7.8.3-MF
- [43] *A Proposal to Construct a Broadband Cable Communications System in Milwaukee.*  
Warner Amex, 1981.  
Available from City Clerk, Milwaukee, Wisconsin
- [44] National Association of Regulatory Utility Commissioners, *Petitioner v. Federal Communications Commission.*  
February 1976, 525 FR 2d 630
- [45] Nash, D., Bollier, D.  
*Interactive Home Media and Privacy Issues.*  
Federal Trade Commission, Office of Policy Planning, 1981.



- [46] **NCTA: Cable Television Developments.**  
National Cable Television Association, Media Services and Research Department,  
1981.  
Cable Industry Statistics
- [47] **Neustadt, R., Skall, G., Hammer, M.**  
The Regulation of Electronic Publishing.  
*Federal Communications Law Journal* 33(3):331-417, Summer, 1981.
- [48] **Final License for the City of Newton Cable Television, Exhibit B Technical Standards,**  
Newton, Massachusetts.
- [49] **Notice of Proposed Rule Making in Docket 20508.**  
June 1975, 53 FCC 2d 782, 784
- [50] **NRC, Technical Specifications, LocalNet.**  
Network Resources Corporation, a Sytek Company, Santa Clara, California, 1981.
- [51] **Mary Alice Mayer Phillips.**  
*CATV a history of community antenna television.*  
Northwestern University Press, 1972.
- [52] **Price, D.**  
The Magic Formula.  
*CableVision* 7(22):4-11, February 8, 1982.
- [53] **Rivkin, S.**  
*A New Guide to Federal Cable Television Regulations.*  
MIT Press, Cambridge, Ma., 1978.
- [54] **Schulthess, P.**  
Data Communications based on Cable-TV Technology.  
In *European DECUS Symposium, Hamburg, Germany, pages 219.* 1981.
- [55] **Sell, G.**  
Beating the Obsolete Trail.  
*CableVision* 7(15):311-313, December 7, 1981.

- [56] Shoch, J., Hupp, J.  
**Performance of an Ethernet Local Network -- A Preliminary Report.**  
 In *Local Area Communication Networks Symposium, Boston*, pages 113-125. May, 1979.  
 Revised version presented at the 20th IEEE Computer Society International Conference (Compcon '80 Spring), San Francisco, February 1980, pp. 318-322
- [57] **Sloan Commission on Cable Communications.**  
*On the Cable.*  
 McGraw-Hill Book Company, New York, 1971.
- [58] **United States v. Southwestern Cable Co.**  
 April 1967, 392 US 157
- [59] Switzer, I., Eng, P.  
**Extended Bandwidth Cable Communications Systems.**  
*IEEE Transactions on Cable Television* 5(1):10-17, January, 1980.
- [60] **Television Fact Book No. 50.**  
 Television Digest, Washington, D.C.
- [61] Tobagi, F., Hunt, B.  
**Performance Analysis of Carrier Sense Multiple Access with Collision Detection.**  
*Computer Networks* 4(2):245-259, April, 1980.
- [62] Tunmann, E.  
**Structuring Two-Way Cable TV Technologies.**  
*CED* 8(4):16-46, April, 1982.
- [63] **Net/One Broadband.**  
 Ungermann-Bass Inc., 1982.
- [64] **Wall Street Journal Staff reporter.**  
**RCA Unit Cleared To Lease Satellite Space for Flat Fee.**  
*Wall Street Journal* 199(59):54, March 26, 1982.

[65]

Warner-Amex.

Warner Amex code of privacy.

*CableVision* 7(22):18, February 8, 1982.

[66]

Willard, D.

Reliability/Availability of Wideband Local Communication Networks.

*Computer Design* 20(8):19ff, August, 1981.