

still

in

MIT's

ONLY

INTENTIONALLY

HUMOROUS

(TOPPED WITH
FINGER-LICKIN' GOODNESS)

PUBLICATION

*Get \$150 cash back when you
buy a Macintosh and Printer!*

*Triple Your Stuff
with the Iomega
Rebate!*

*Take advantage of the lowest Apple
printer prices of the year!*

*Save big with Dell
Holiday Bundles!*

Enter to win a Zip Drive!

Harvest Savings

sale going on now at the
MIT Computer Connection
x3-7686, mcc@mit.edu



In "De-Engineered" Voo Doo

Now under new management!



Editorial — page 5

The new Editor's first words.



Letters to Voo Doo — page 6

Flame on. FIRE! FIRE! COOL.



Getting Santa Claus — page 8

Don't we all deserve just a few more presents?

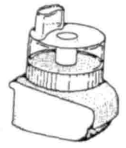

Shticks and untitled — page 12

Iguanas need a healthy mix of wet and dry food.



Fat Stick Man — page 14

Otherwise they are subject to serious health problems and are prone to infection.

Zen for Stupid People — page 16

It's about time they stopped discriminating.



☛'s Journal — page 16

I guess the cat burglar got him.

The Horror — page 18

That doesn't even begin to describe it...



Engineering at MIT — page 19

If only it were true.



Captain Coconut — page 20

Yet another superhero roaming the halls.

Eggers — page 28

Straight from the Globe Kids' Pages.



From the Publisher



Publisher
Phosphorous

Metallic
Cyberdrone
James Tanabe

Business Manager
The Voo Doo
Economist

Crusty Alums
Jason Bucy
Hoyt Bleakley
Kent Lundberg

Emperor of
Production
Lex Nemzer

Head Goon
Farhad Evrahimi

Artist
Extraordinaire
Rigel Stuhmiller

Wide-Eyed Neophyte
Cynthia Randles

Copy Editor
Lady Luck

Cover Artist
Carolyn Jones

Contributors
Don Hyun
David Friedman
Hani Sallum
Margaret Oh
Thomas Colthurst
Stephen Gilbert
Aalok Shah
David Hon-Egg
Aneel Nazareth
Nick Matsakis
David Pooley
Cyrus Dolph V

Volume 78, Number 2

Voo Doo Magazine
MIT Room 50-309
77 Massachusetts Avenue
Cambridge, MA 02139
617/253-4575
voodoo@mit.edu

Voo Doo, MIT Journal of Humour, (ISSN 1066-2499) is published "bimonthly" in September, October, December, February, March, and May by Phosphorous Publishing. All material ©1996 Voo Doo Magazine and individual authors. Single copy price \$2, six issue mail subscription \$10. Submissions accepted from any past-or-present MIT affiliate. Advertisers: call for rates, page sizes and production deadlines. Any similarity to persons living or dead without satirical intent is coincidence. Voo Doo is not printed on recycled paper due to concerns about the environmental impact of the "de-inking" process, but is printed with soy-based inks so if you chew it long enough, it tastes like tofu. Special thanks to the UA FinBoard for financial support. Printed at Chuck River.

Voo Doo (vōō' dōō) n., [Slang c.1920] hubbub; excitement; mischief; *an ideal name for a humor magazine*

Factsheet 5 Blurb-o-Tron (corrected, reviewed issue 75.2, from F5#50) : Humor from the unwashed students who wind up designing important things like computers and nuclear devices. What the fuck happened? Suddenly, Voo Doo got funny. Like, laugh out loud on the tram funny. Is this the same zine? It must be, as there are still things I Just Don't Get. I doesn't matter, I get enough of it. Where else are you going get the Marilyn Monroe/Elvis Presley/JFK connection? Or the results of last year's IgNoble Prizes? College humor at its finest? Yeah, well, maybe. Trades OK/back issues available/paid ads/prints letters/no submissions. Price: \$2.00 Subs: \$10.00 for 6 issues.

Check out the Voo Doo Magazine Homepage
and the College Humor Magazine Homepage

<http://web.mit.edu/voodoo/www>
<http://web.mit.edu/voodoo/chm.html>



EMMA LAZARUS

Next Submission Deadline: February 7, 1997.

Letters to Voo Doo

Dear Loodoo

i like your
cat!
~~he's~~
family! i have
a cat his name
is tiger.
-Nathan
G.

age 4 going
on 4 1/2

Dear Norton,

Phos is out on an oatmeal bender, but asked that I tell you 'Hi,' and that he thinks you're just swell! He wants you to be the number one member of the Phos fan club! Your T-shirt is in the mail!

Dear Loodoo,

Thank you for
the tour of your
office; liked the way
best congratulations
on cleaning out
UX funding!

-Chuckie
V.

Dear Chuckie,

Phos is out on an oatmeal bender, but asked that I tell you 'Hi,' and that he thinks you're just swell! He wants you to be the number one member of the Phos fan club! Your T-shirt is in the mail!

Dear Phos,

So I came to M.I.T. In the course of events and encouraged by its title, I picked up the M.I.T. Journal of humour---sophisticated humour, no less--and what do I find? Not a single recipe. Not a single damn recipe. I've got an idea: how about you print a few fucking recipes?

Yours so very truly,
Julia Child

Dear Julia,

Phos is out on an oatmeal bender, but asked that I tell you 'Hi,' and that he thinks you're just swell! He wants you to be the number one member of the Phos fan club! Your T-shirt is in the mail!

Dear Phos,

I don't know who else to go to. I'm a freshman here and am just having the worst time fitting in. My grades are miserable, people just ignore me at parties, the folks on my hall play cruel jokes on me...I just try to laugh it off and keep on going, thinking 'MIT is not an easy school,' and 'What do I care what other people think.' I've never been away from home for more than one night, and homesickness rips me apart every night. My boyfriend back home just started dating my sister and i forgot my athena password. Whenever i talk to my parents about it they just say that I've got a lot of growing up to do. I think i'm at the end of my rope, Phos. what should I do?

-Desolate

Dear Desolate,

Phos is out on an oatmeal bender, but asked that I tell you 'Hi,' and that he thinks you're just swell! He wants you to be the number one member of the Phos fan club! Your T-shirt is in the mail!

THE PHOS
FAN CLUB™
T-SHIRT!
ORDER YOURS
TODAY!!



FRONT

#1 FAN!



BACK

Are you plagued by unnatural heterosexual feelings? *Help is possible.*

Millions struggle with uncomfortable heterosexual urges and long for the freedom of homosexual relations. But many find themselves unable to break the cycle of their unhealthy addiction to the opposite sex. It is a sad fact that not everyone is born gay or lesbian, but most people have within them the potential to experience a normal range of attraction, and some are capable of complete conversion. Through intensive therapy and cultural immersion, we can help you get in touch with your inner queer.

Here's what some of our clients have to say:

"This is wonderful! I thought I'd never be able to love a man!" *A.J., Cambridge*

"It's certainly changed my life for the better." *M.L., Nahant*

"Great fun—a real eye opener." *T.W., Quincy*

For more information,
please contact

The Curving Path
32 Woodbury Rd.
Cambridge, MA
02139

APPLY TO THE COUNCIL FOR THE ARTS GRANTS PROGRAM!

**SEE HOW
EASY IT IS**
Step by Step!



FREE! REVEAL YOUR TALENT FOR ART!

1. Obtain Guidelines, read them twice, fill in application
2. Submit application by January 17, 1997
3. Provide supporting material by January 31, 1997
4. Meet with Grants Committee member on February 13, 1997

Extra tip: Attend the IAP Seminar "Getting a Grant from the Council for the Arts at MIT" on January 7 at 3:30pm in E15-095

Call 253-4005 or e-mail <cohen@media.mit.edu> for more information

Getting Santa Claus

by Don Hyun

It didn't feel like Christmas morning at all. When I looked outside, the dark clouds added a feeling of gloom to the silent, falling snow. There's always something a little creepy about something as noiseless as morning snow fall. That's why I hate to be the first one up on winter days. Unfortunately, it was Christmas and although, I'm twelve and all grown up now, I still love presents, even more than I hate gloomy winter mornings. But, my favorite presents aren't from my parents or any of my relatives. Although I bet they spend the most money, I'm not a big fan of sweaters, socks, and clip-on ties. My favorite presents are the ones strewn all over our snow-covered yard. They're from Santa himself. Every Christmas morning since I can remember, there have been presents scattered all over our neighborhood, thanks to Jerry.

Jerry is the children's barber who lives a couple houses down from us. He's home most of the time because he cuts hair in his basement. He has quite a reputation with us kids. The neighborhood kids get their haircuts for free because we used to hang out with him a lot. And every time he gave us a haircut, he used to tell us that he's giving us a million dollar haircut because that's the only way he knows how to cut hair. He says he wouldn't even know how to give a nine dollar haircut believe him. I mean, I look real nice after his cuts. He's always telling us, "Y'know kid, every time I give you a haircut, I'm giving you a million dollar present. I'm the best Santa Claus you'll ever have. Now don't you forget that when you grow up and become a millionaire and old Uncle Jerry's over here dyin'." He's a great guy. I don't know why he doesn't have any family, but he doesn't like to talk about it too much so we don't ask. I don't think it matters too much though. He's always out and about in the neighborhood and playing with us. We play hide-and-seek, football, kickball, tag, and just about all the games that neighborhood kids play. And even though Jerry's probably 40-something years old, he's always playing with us. Well, that was until a few months ago.

My parents were still asleep as usual on Christmas mornings. I think they do it just to spite me.

I remember one year, they wouldn't wake up until noon. I went into their room at about nine o'clock and asked them to wake up and shook'em up a little, but my step-dad just pushed me against the wall real hard with one of his hands. My head hit the wall pretty hard and I just ran out. I ran into the bathroom and cried. Not a lot, because I'm a boy, but a little. My head hurt kinda bad and it was bleeding --- bleeding all over the sink. The doctor told me later that it's because the head is where you bleed the most. When they woke up at noon, they saw me in the bathroom with all the blood running down my face and all over the bathroom walls, mirror, and sink, and rushed me to the hospital. I guess I was sleeping on the bathroom floor. All the neighborhood kids thought I was pretty cool, because I had 7 stitches in my head, and they called me Frankenstein for a while. That was probably the second best present I got that year. The best present was from Santa. It was a remote controlled car. All the boys in the neighborhood got one. Actually we kind of stole it from Santa.



Every year, we ploy to catch Santa and take all his loot. Ever since I can remember, right after Thanksgiving, all the kids gather in Jerry's garage, and write a letter to Santa, but not from us. We pretend we are these immaculate kids and say that we live with Jerry. We explain how poor we are, and how good we've been and how we all a such and such toy to be happy in our oppressed lives. Two years ago, there was that remote controlled car craze and all of us asked for remote controlled cars. Anyway, around December 1st, after Jerry sends out the mail, we all get together at Jerry's again and decorate his house. We put lights up everywhere --- all over the trees, around the windows, on the lawn, lacing the steps to his door, and a big blinking sign on the roof that says, "Santa! Land HERE!" But, what

Santa doesn't know is that we also install a HUGE mouse trap on the roof. Jerry calls it the SANTA trap. It is HUGE! About six of us have to climb the roof and help him set it. All of us have to help Jerry set the mouse trap because it's so powerful. I remember the last time we tested it. Six of us, including Jerry, had to heave the snapping lever into place and Jerry ever so carefully, set the trap. We put a watermelon where the lever would whack down. The whole thing vibrated as if it was about to go off any second. Jerry warned all of us to stand back. We all stood outside of the garage looking in at Jerry carefully aiming a rock at the center of the trap. We were all holding our breath, even Jerry. Jerry tossed the rock at the trap and jumped back as fast as a slightly overweight middle-aged man could. Thank God we were all standing WAY back, because the trap snapped into the air and hit the ceiling of Jerry's garage making the loudest noise I've ever heard. It was like a shotgun fired right next to my ear. The noise was like a stick of dynamite exploding --- BANG!! All of us were stunned, even Jerry as we stared at the hundreds of pieces of watermelon all over Jerry's garage. We all stood in awe of the powerful mechanism of destruction. Then, Jerry broke the silence, "That'll get the ol' bastard... heh-heh" We all laughed.



When we wake up Christmas morning, the first thing we do is run outside to take a look at the presents that Santa dropped. Then we'd walk down to Jerry's house to check the Santa trap. I was usually the first one there. We never actually caught Santa. Usually, left in the trap were Santa's hat along with miscellaneous sleigh parts and sometimes a reindeer tail. Jerry was always sitting in his garage with the garage door wide open. He's usually bundled up in his winter clothes and sipping hot apple cider from his favorite mug. Pointing at his roof, he'd usually exclaim, "Got away again... maybe next year, Bobby..." "Then he'd ask how I made out with the loot. "So Bobbyboy, did you get anything?.... I mean, it looked like the trap must have scared the bejeezus out of him again... you think he'd learn that we try to catch him every year... Silly Santa... Anyway, it looked like he dropped a whole

load of stuff all over the neighborhood." I'd show him the present I found in my yard, and we'd play around with whatever it was until eventually all the neighborhood kids came out to Jerry's garage. Sometime later in the day, Jerry would climb the roof and gather up all the Santa paraphernalia and hand them out... except for the hat. He always kept the Santa hats. They hung orderly in his garage-one for every year. Last year was the 12th year he tried to catch Santa. So, underneath the twelfth Santa hat nailed to the wall is an inscription written with a permanent black marker, '1994, Got Away again.'

It wasn't the usual Christmas this year. Things have been quite different. We didn't write the letters to Santa. In fact, I haven't even spoken to Jerry since September when the Tommy incident happened, but strangely enough, outside the window, I saw presents all over the neighborhood. Excitedly, I jumped off of my bed and find my socks, jacket, and snow pants, wondering what Santa could have dropped in our neighborhood this year. I ran out of my room and opened our front door to be greeted with a big package. It was a package about as big as a milk crate wrapped in plain white paper --- or at least what used to be white paper. The entire package was soaked in red. I wasn't sure if it was blood, but it was running through the paper onto the snow. The package was held together with a single tweed rope. On top of the package was a note held there with a finger as a paper weight --- 'Flying Venison.' The finger looked like a gag gift, but all the dried up blood made it look pretty real. I picked it up feeling its rubbery skin and another note tied to the middle joint of the finger was revealed --- 'To: Greg.' I wasn't sure what venison meant, but I knew the package was for my step-dad and so I left it alone. He's yelled at me before about touching his stuff. Setting everything exactly as I had found it, I started walking out of our driveway. Usually, the gifts were strewn about our lawn, but the closest gift to our house was in the middle of the snow covered street about few feet from our driveway. The package was pretty small --- a little bigger than my hand. I picked it up. The present was neatly wrapped in the usual festive, green and red wrapping paper. But, it was addressed to Barbara. Usually the presents that were left in our yard was addressed to me, but I suppose, technically, this present wasn't on our yard. But, it wasn't on anyone else's yard either. I didn't know anybody in the neighborhood named Barbara. So, I opened the present. It was a My Little Pony. Looking down the street toward Jerry's house, I saw

a lot more presents. As I got closer to Jerry's house, more and more presents were strewn about the snow covered road. They were all addressed to people that I've never heard of --- Eve, Michael, Mitzy, Daniel, Janice, etc. I picked up a few presents and opened them. I found a coffee maker and a pair of scissors. They both looked a bit used, but I wasn't sure if they really were. They were both in their original boxes, though. When I finally arrived at Jerry's, there were so many presents all over the place that I could hardly see the snow. It was as if there was an explosion of presents at Jerry's house. Then it all hit me. I saw Santa's hat hung on the garage door handle with a note attached. When I looked up at the roof, I was stood motionless, mortified.

In September, there was this huge "controversy" with Jerry. I'm not sure what that word means, but my mom and dad said that basically it's a bad thing and I should never talk with Jerry again. They were talking very quietly and solemnly about him at the kitchen table one morning. I asked, "What are you talking about? I thought I heard you guys say something about Jerry." "Yes, we've heard that he's in quite a bit of trouble," my mom replied. "What kind of trouble?" "Well... you know Tommy, your friend that lives at the top of the street?" "Of course." "I guess his mom is saying that Jerry was touching him." "What?... What do you mean?" This is when my step-dad started yelling at me, "For God's Sake! Jerry molested Tommy! Can't you understand that?.. And if I ever see you talking with that guy again, I'm going to beat you senseless, you understand me?" Mom started yelling at my step-dad, "Greg! Will you stop yelling at Bobby! He doesn't know what that means! And don't you ever threaten him again. Besides, I heard Jerry denies the whole thing and they're going to court this Monday." My step-dad retorted, "You better be kidding me if you think he's actually innocent. All that guy ever does is play around with our little boys. He's not a normal man. And I bet he'd put his hands all over Bobby if he had the chance, that bastard. Bobby, do you hear me? You better not go near that guy again, or I swear... I'm gonna spank you 'til you're blue!" Then, my mom started yelling again, and they got in another huge fight where they don't speak to each other for a few days. I heard my mom talking to a woman in the supermarket a couple of weeks ago talking about how they found Jerry not guilty. But, it didn't matter. My step-dad kept telling me I'd better not even go near that house ever again. Basically, I was forbidden to ever talk to Jerry again.

And it was a month ago, that I saw him, and I didn't say a word to him. I was walking by his house, when I saw Jerry's garage open for the first time since the whole "controversy." He yelled out to me, "Hey Bobby, how's it going." He was sitting on his folding lawn chair inside of his garage --- alone. I've never seen him look so alone. Even though he didn't have any family, he considered all the kids in the neighborhood his family --- his best friends. And now, here we were with only 15 feet of driveway and too many feelings to make into words between us. I stopped and looked at the ground. When I looked up, he gave me a weak smile, and asked, "What's wrong kiddo?" I didn't know what to do so I just stared at him and my mind raced across thousands of thoughts. Should I ask him about the Tommy incident? Should I ask him how he's doing? Should I ask about how he's gonna catch Santa this year? Should I ask about giving me another million dollar haircut? Should I tell him that I don't believe any of it? And how I miss him terribly and how I wish I could talk to him but I can't because my step-dad is going to beat me! I wished none of this would have ever happened. I started crying uncontrollably. Between my sobs, I saw Jerry look at me sadly with his distraught face. I think he was crying too. He opened his arms and gestured for me to give him a hug. I didn't hug him. I ran home as fast as I could crying harder than I've ever cried. I just ran away from him.



The last time I saw Jerry was a couple of weeks ago. My step-dad was driving me home from school and he was outside stapling all of his Christmas lights --- alone. I smiled when I saw the Santa trap on his roof. The lights on the roof spelled out the usual, 'Santa! Land HERE!' My step-dad slowed down the car and rolled down his window. "DAMN IT JERRY! YOU'RE SCARING THE KIDS!! Why don't you get your cabbage ass down from the roof and stop this damn nonsense. We all know what you did to Tommy. It doesn't matter what the court says! We all know what you did! The whole neighborhood knows. I'm surprised you can even show your face in daylight around here, you damn molester!" Jerry didn't say a word. He didn't even look. He just continued stapling the lights to the roof as if he

didn't hear a thing. My step-dad, he doesn't like Jerry at all. He has never liked him.

Two years ago, when the Christmas incident happened, Jerry found the stitches on my head as he was cutting my hair. He asked me immediately, "Hey kid, what the heck happened to your head?!" I told him that my dad accidentally pushed me too hard and I hit it against a wall. Without a second thought, he ran out of the garage to my house. I got up to follow him, but by the time I was out of the garage, Jerry's face was less than an inch away from my step-dad's face screaming loud enough for the whole neighborhood to hear. "Don't you ever lay another finger on that boy again. You are a pathetic excuse for a father. What was the last thing you gave him except a concussion, you friggin' monster. YOU... DON'T... DESERVE... TO... BE... A... DAD..." My step-dad just looked at his wide eyes staring him down. And there was a long silence except for Jerry's huffy breathing. It was the type of silence that happens when everybody knows the truth has been said and there can be nothing more that can or should be said.

Now, every chance he gets, my step-dad is putting down Jerry and calling him a molester this or homo that. The worst part is, I wasn't strong enough to not be on his side. I was too weak to stand up for Jerry. And as I stood outside of Jerry's

house, I knew that I had done something so wrong, that I would never forgive myself --- something even Jesus would have a hard time forgiving. I helped kill Santa Claus. Santa's hat was hung neatly on the garage door handle. Stapled to the thirteenth hat was a note, 'You got him.' I looked up on the roof to see Santa's bloody, mutilated corpse lying in two pieces. The trap had worked perfectly. I chopped him into two pieces. His legs were thrown to the other side of the roof, and his upper body laid slumped over the gutter right above the closed garage door. His arm hung over the edge of the roof like a limp branch and his right hand was missing a middle finger. I swallowed hard. I swallowed the fact that I helped kill someone who has done nothing but spread happiness and love. I looked at the lifeless face on top of the roof that used to joke about giving me million dollar haircuts. That's when I realized Jerry was Santa Claus and we got him. We killed him.

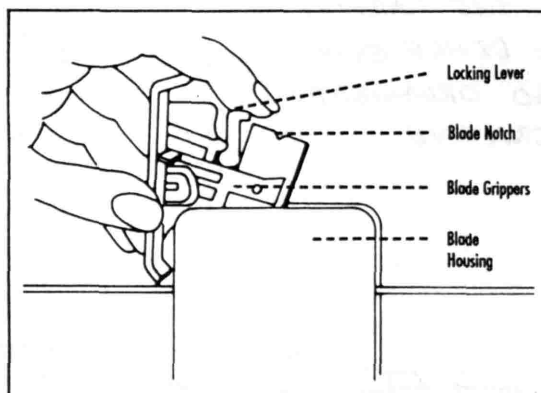

To insert blade:

1. Lift top of Blade Housing and retract Locking Lever.
2. Slip blade between Blade Grippers.
3. Press pen or pencil tip against Blade Notch to position securely.
4. Snap Locking Lever over edge of blade.
5. Close Housing and slide to top of Cutting Arm.

Cutter is ready for use.

To remove blade: Reverse procedure.

SHTICKS

David Friedman

Nerd A wants to pad his resume. He writes for the Tech.

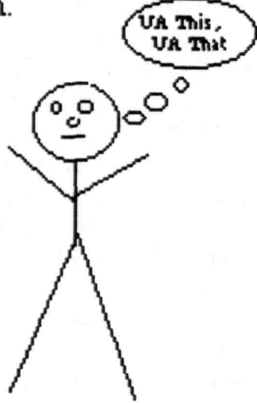

Nerd B thinks he's funny. He writes for Voodoo.



Nerd C ran out of toilet paper and is in desperate need for some more. He writes for the Thistle.



H. Sallun

SO, AS YOU CAN SEE,
THIS IS THE LARGEST
NUCLEAR DEVICE EVER
BUILT, SO ORGANIZATION
IS IMPERATIVE.

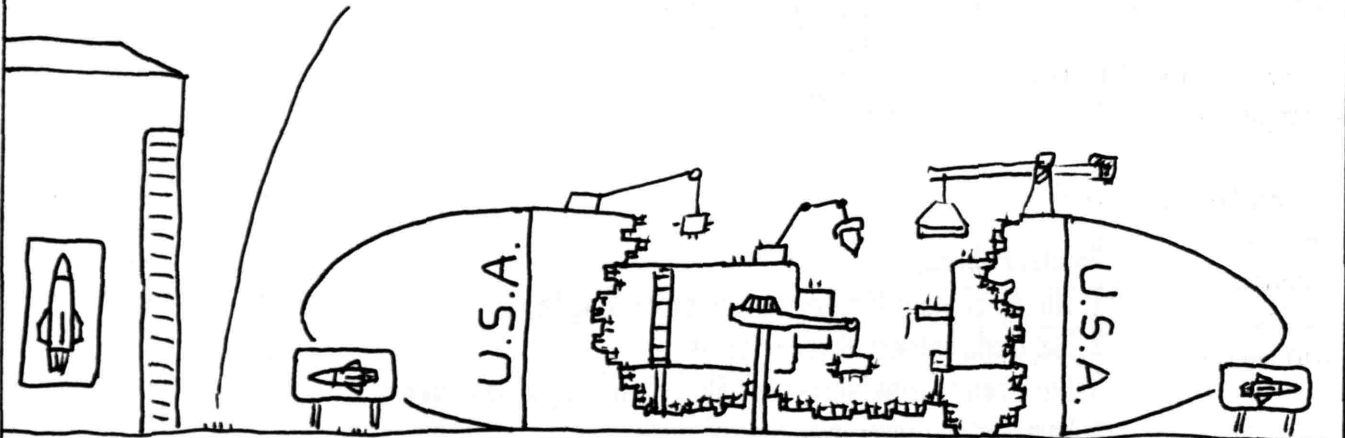

IAP EXTERNSHIPS

The Student Alumni/ae Connection is offering
50 Externships across the country during IAP.

WHERE WILL YOU BE?



Key

- Externship Site
- ✕ Multiple Externship Sites

Check our homepage
for details about each
externship at:
<http://web.mit.edu/sac/>
OR
Stop by 10-140 to look at the
externship offers notebook.

WHAT IS AN EXTERNSHIP?

An externship is an opportunity for students to connect with alumni/ae to observe and participate in an area of potential career interest. This is an unapaid position.

WHO IS ELIGIBLE?

All undergraduate students who apply.

HOW DO I APPLY?

An application (available in 10-140) and a resume are required. The alumni/ae who are sponsoring the position select the student extern.

THEN WHAT?

You will be contacted by the Student Alumni/ae Council to let you know if you have been selected. It is then up to you and the alumnus/a to "connect" and arrange details.

Important Dates

- Deadline for submitting applications: **November 27, 1996**
- Student applications mailed to sponsors: **December 2, 1996**
- Deadline for sponsors to notify the Student Alumni/ae Connection of their externship selection: **December 9, 1996**
- Students notified of their acceptance to the Externship Program: **December 11, 1996**
- Students and sponsors make individual arrangements for the externship: **December 9, 1996- January 3, 1997**

A SAMPLING OF EXTERNSHIPS NOW AVAILABLE

- Cardiac Surgery Extern
- Analyst, Venture Capital
- Spacecraft STV Testing
- Family Practice Medicine
- Software Engineering
- Mechanical Engineering
- Biomedical Engineering
- Environmental Engineering
- Academia/Professors
- Aerospace Engineering
- Law
- Investment Management

For information call Theresa Lee at 253-8280
or e-mail tjoc@mit.edu

A DAY IN THE LIFE OF:
OUR FRIENDLY NEIGHBORHOOD EMOTIONAL
FAT STICK MAN - THAT'S ME!!
MAGGIE OH

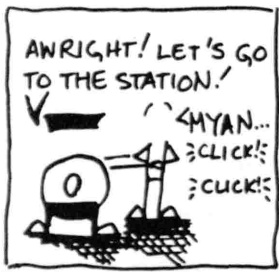
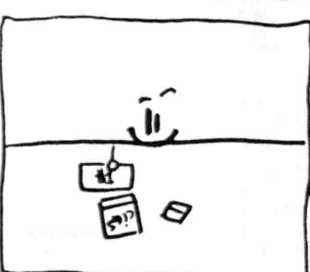
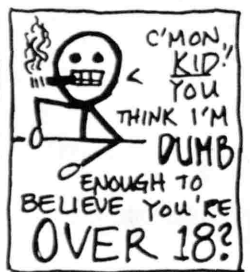

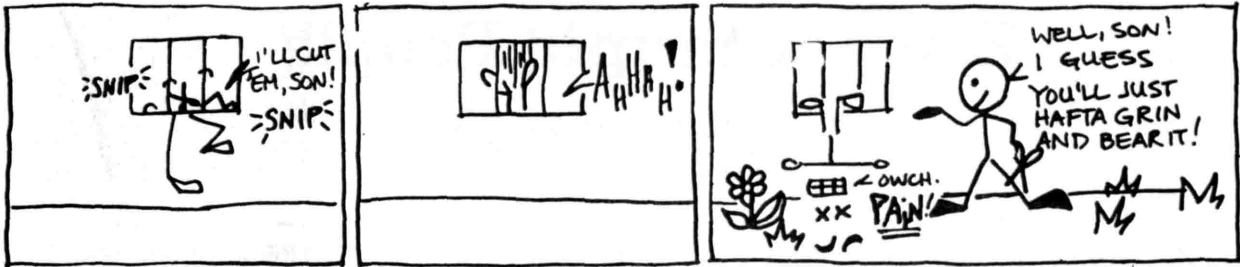

I WAS PARALYZED WITHOUT MY EYEBROWS! YOU SEE, THEY'RE MY "BRAIN." I COULDN'T FUNCTION WITHOUT THEM. SO ONE DAY, DAD TOOK ME TO THE LOCAL EYEBROW OUTFITTER SHOP...

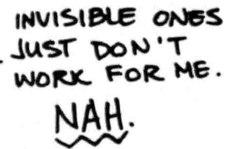

YEAH!



THE END

AND SO ENDS A DAY IN THE LIFE OF OFNEFSM! 2-18 1996

Zen For Stupid People

by Thomas Colthurst

By popular demand, we present ZEN FOR STUPID PEOPLE, a collection of Zen koans, riddles, and parables for folks who watch too much daytime TV.

* What is the sound of two hands clapping?

* If a tree falls in forest, and someone is around to hear it, does it make a noise?

* If you meet the Bhudda in the road...well, step aside! Make way! This is THE Buhdda we're talking about!

* A monk came to Joshu and asked "What is Zen?". Joshu replied "Have you eaten your rice?". The monk said "Yes." Joshu responded "Well, go ahead and have seconds! There's plenty enough to go around!"

Hearing this, the monk was not enlightened.

* Two monks were arguing about a flag. One said, "The flag is moving." The other said, "The wind is moving." A Zen Master happened to be passing by. He admonished them, saying, "Don't you guys have anything better to argue about? Jesus!"

* One day Tokusan told his student Ganto, "I have two monks who have been here for many years. Go and examine them." Ganto picked up an ax and went to the hut where the two monks were meditating. He raised the ax, saying, "If you say a word I will cut off your heads; and if you do not say a word, I will also cut off your heads."

Both monks continued their meditation as if he had not spoken. Ganto dropped the ax and said, "You are true Zen students." He returned to Tokusan and related the incident. Tokusan immediately had him arrested as a homicidal maniac.

* Question: "Does a dog have Buddha-nature?"
Answer: "No."

* Question: "Why did Bodhidharma come from India into China?"

Answer: "He was bored."

* Zen is drinking when you are thirsty, sleeping when you are tired, and taking the trash out on Tuesdays.

*'s journal, by god!

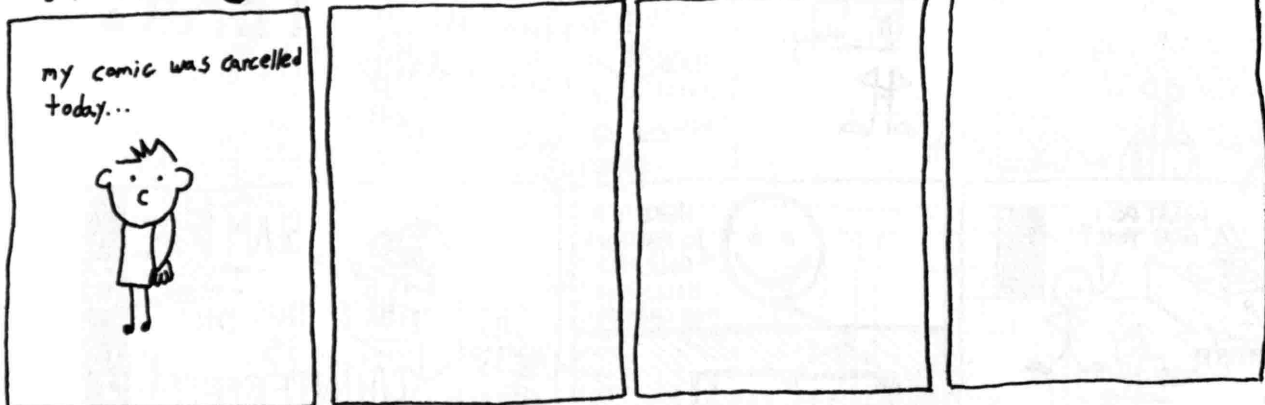

Does it bother you when people don't flush the toilet?

Have no fear...

Urocheck

has been recently installed in a toilet or urinal near you.

Using advanced biochemical analysis, ***Urocheck*** can identify someone by his or her urine. The ***Urocheck*** system builds a database of urination habits, and if someone does not flush appropriately, when that person returns to the toilet, he or she will experience a mild electrical shock conducted along the stream of urine.

MIT and ***Uronalysis, Inc.*** will be soon be linking urinals and toilets throughout the campus as part of the new Neptune network, so that appropriate etiquette will be insured everywhere.

The Effluvia messaging system (based on Zephyr) will also be installed to facilitate more conversation in the restrooms of our urban jungle; you'll know when a friend sits down beside you or across campus. No worry of misidentification; our DNA-based analysis is more reliable than Kerberos.

We also hope that ***Urocheck*** will eliminate harrassment between stalls; Campus Police and the ***Urocheck*** database can help you find any aggressor. Privacy need not be a concern; officers promise not to access the database except in the case of such emergencies.

Uronalysis, Inc. also produces ***Urocheck*** for home use (curb those inconsiderate roommates) and swimming pools. Future models in our *Femme-Fatal* line will also monitor whether users lower the seat.

Uronalysis, Inc.
"There's no need to get pissed off."

The Horror

by David Friedman

It all began on a cold winters night at MIT. It was 3:54 AM and I had this ugly paper due at 10. So I'm at athena working on the paper when I decide that I should save it. I haven't saved for 3 pages so I figure that that's a good idea. I grab the mouse, bring up up to the File button on my EZ window and then...

Nothing.

The screen freezes. The mouse won't move. Ahhhhhhh!

As soon as the initial panic wears off, I decide to ask for help. Checking my .anyone file, I realize that none of my friends are around. So I look around the cluster. Judging by his appearance, the only other person in the cluster is either a homeless guy or a grad student.

"Excuse me"

No response. He keeps typing away. Sneaking a peek at his screen I see diagrams, graphs, everything. But no response.

"Excuse me"

He turns to look at me with fright in his eyes. The poor guy hadn't looked at another human being in ages. I felt sorry for him, but I had my own problems to deal with. I decided that I had better tackle this one on my own.

I log in to an adjacent computer and look up olc. "How to get a snail in your background", "Advanced Xbombs", "Are you really sure I can't eat in the cluster?" The list goes on and on, but nothing there can help me.

I had only one more option. It wouldn't be pretty but I would have to do it. I picked up the phone, and ever so carefully dialed those five numbers; those five number which by themselves mean nothing, but combined... I shudder to think.

3-7-7-8-8

"Hello. SIPB!" came the shrill voice.

There is no turning back.

"Yes. Ah hi. Can I ask you a question?"

"You just did."

Oh no! The oldest SIPB witism in the book. And I fell for it. And to make matters worse, the whole SIPB collective was laughing at me. I could just hear it over the phone line: "You just did- Ha

Ha. That's a good one" "Yeah. That one belongs in /sipb/humor/you-just-did"

Finally, the laughter died down.

"Can I ask you two questions?"

Score one for me. We were now even.

"My screen froze"

"Hey guys! His screen froze!"

Uh-oh.



"Check /sipb/weather/temperature. It's 15.7 degrees farenheit outside. I'm not surprised."

Damn them. 2-1 theirs. But I sensed they were done toying with me and ready to answer my question. I hoped.

"I can't move my mouse."

"What kind of computer are you on?"

"Uh. A sun"

"What kind of sun?"

"Sparc 5"

"What kind of sparc 5?"

The duel was getting tense.

"uhh. color?"

"ok.."

2 all.

".. what cluster are you in?"

"building 37"

"37 what?"

"37-332"

"What machine?"

"37-332-5"

"Incorrect. The correct answer is

37-332-5.mit.edu"

Very sly, SIPB. Very sly. 3-2 yours.

"What were you running at the time?"

"Hmm. Let's see. Netscape, EZ.."

"Hey guys!!!"

Damn.

"Hey guys! This guy was using EZ!!"

Here they go again.

"I used EZ once! in 1912!"

"EZ may as well be ARA food with all the bugs in it!"

"Hey guys! We should start a newsgroup alt.ez.users.losers."

I had to say something. I couldn't just sit there and listen to this. (Actually, I was standing. Athena chair shortage and all.)

"What do you expect me to use?"

Oh-Oh. Maybe I shouldn't have said that.

"Umm. Did you ever hear of latex?"

"Yeah I guess. How do you use that?"

"RTFM!"

Click.

That was helpful.

Fortunately for me, a course 6 friend of mine just happened to log in and told me to look in /tmp to find my file so all was not lost. All in all, I'd say it was a learning experience. I dare not think what would have happened had I not only called SIPB, but actually walked in to the SIPB office. I have done that too, but that's a tale for a different time.

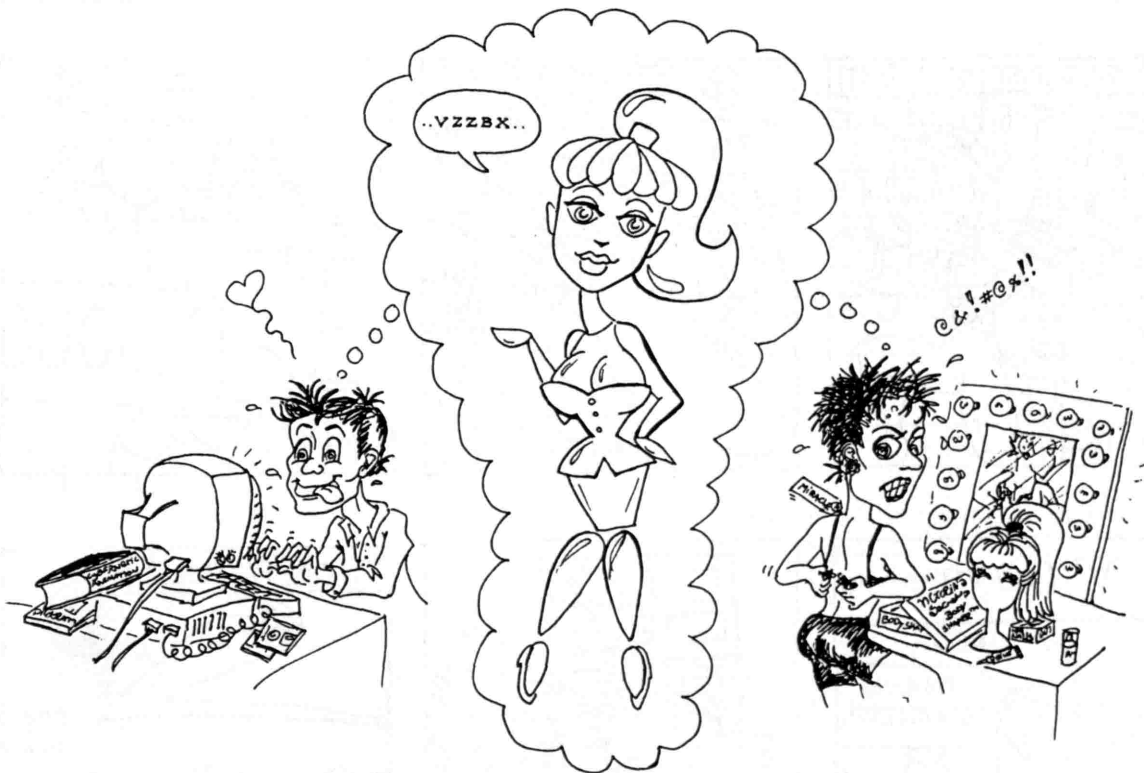

ENGINEERING AT MIT.

SRB'9

COCONUT

DEFENDER OF JUSTICE, OPPRESSOR OF EVIL, AND MIXER OF THE BEST PIÑA COLADA ON EARTH.
A FEW EXTRA PIECES OF PAPER FROM AALOK B. SHAH

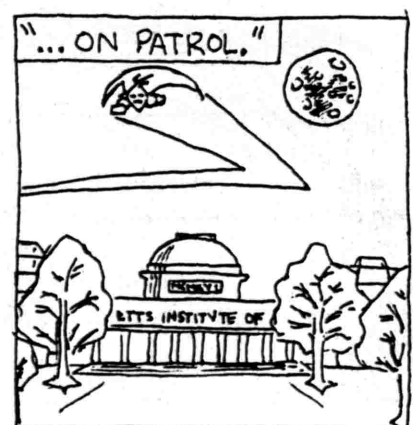
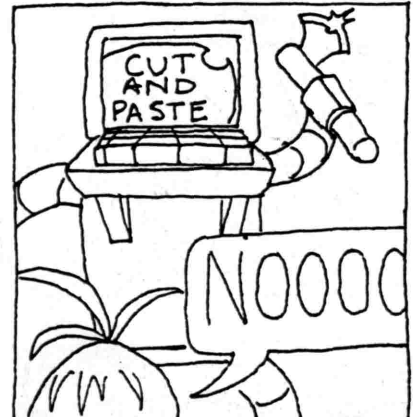
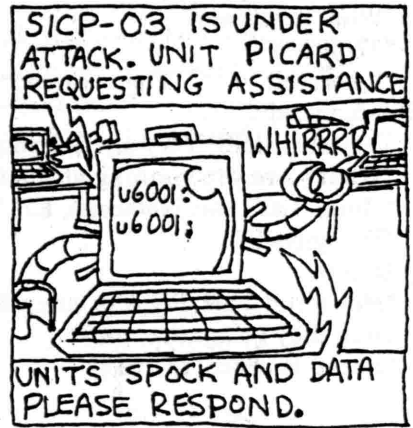

MEANWHILE, IN THE HIDDEN ATHENA CLUSTER UNDER MASS AVE THAT SERVES AS THE SECRET BASE OF THE UNDERGROUND HACKERS' ORGANIZATION KNOWN AS VERMINSTRIKE...

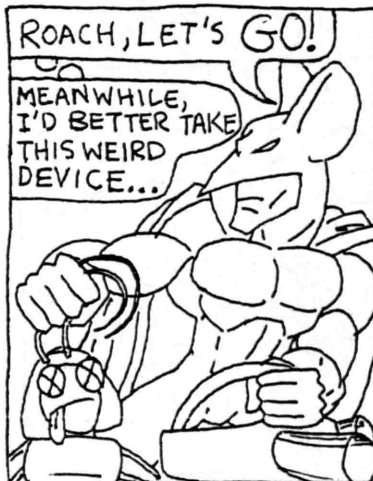
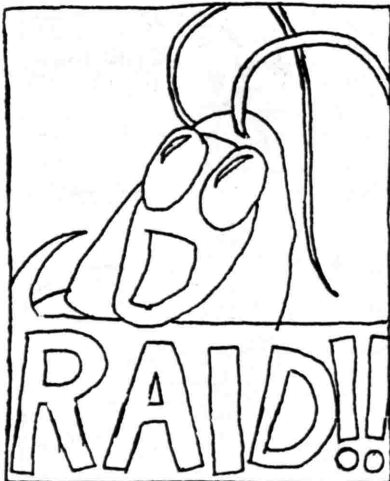
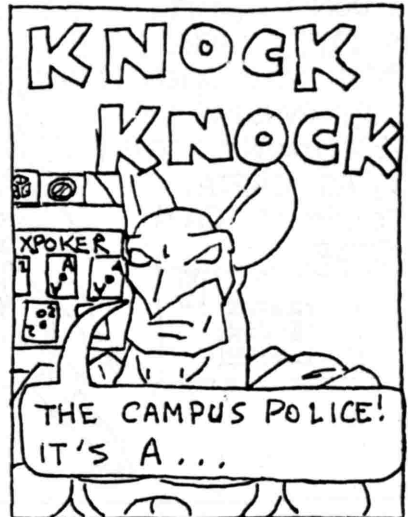
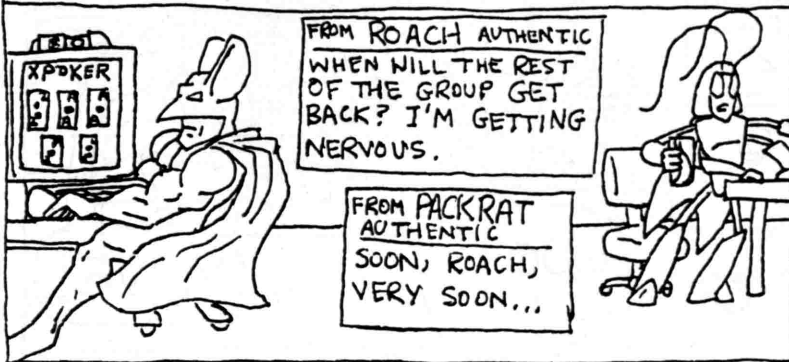

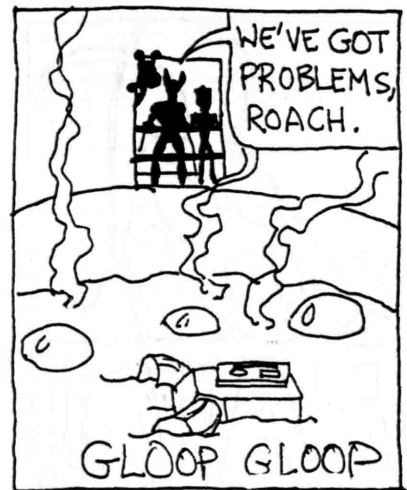
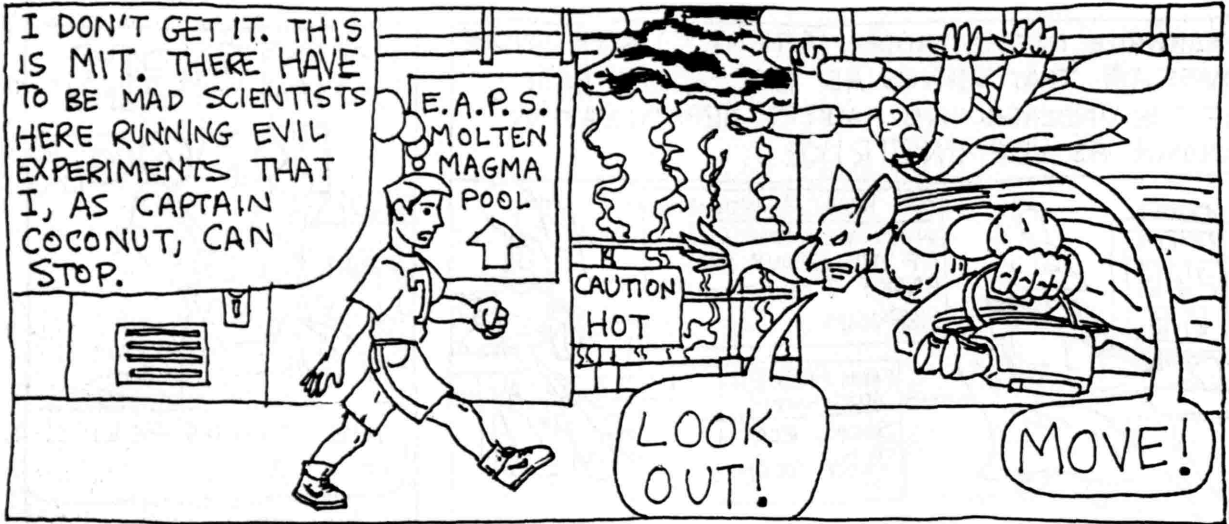



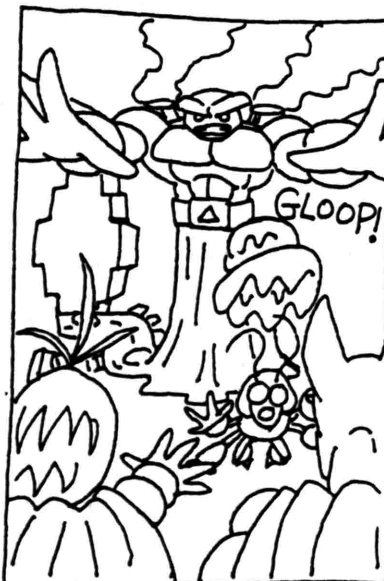
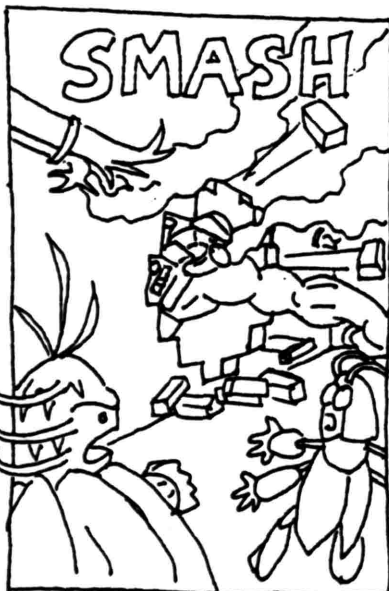

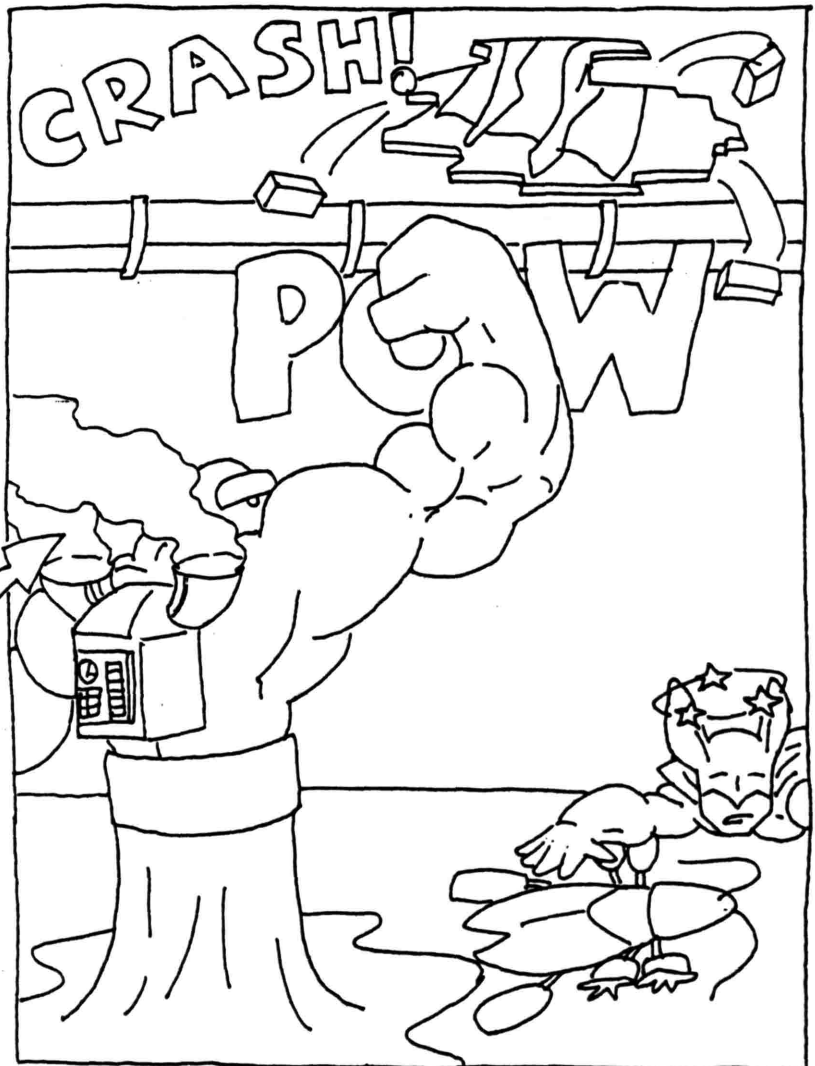
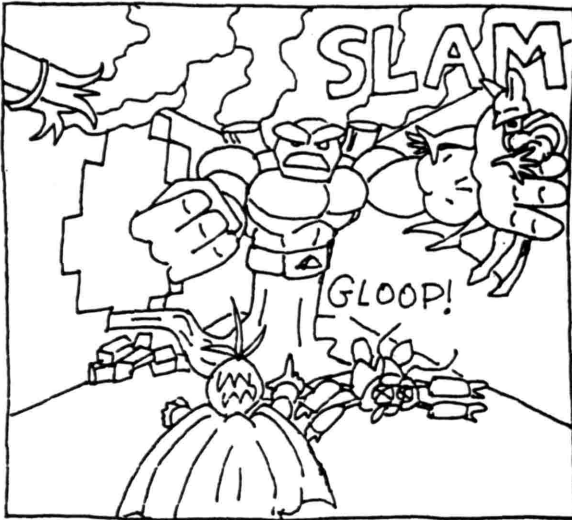

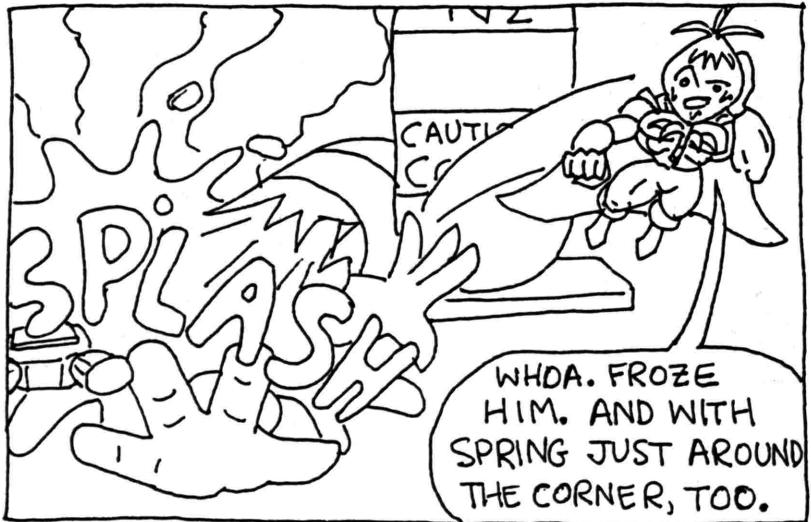
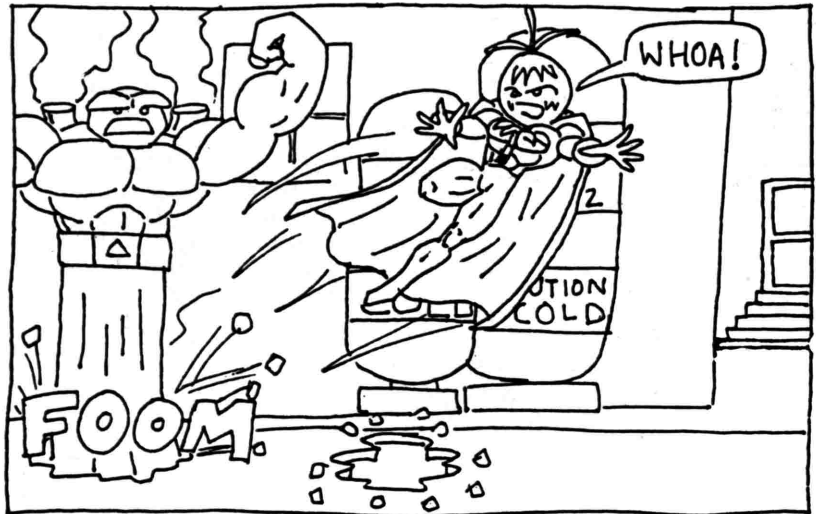





LETHAL
INJ-EGG-TION

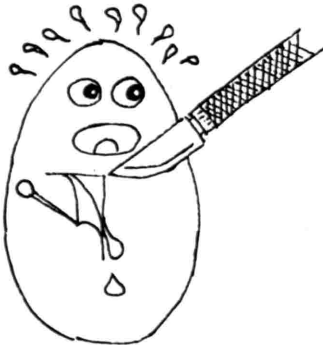
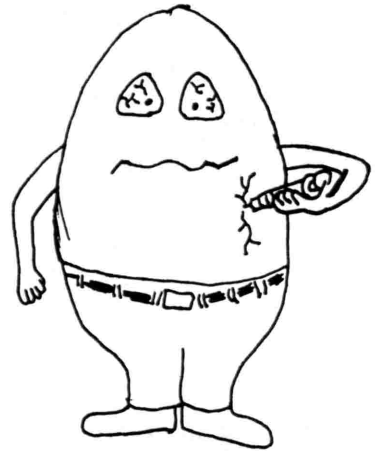

Vivis-EGG-tion



Nicholas N-EGG-roponte



Domin-EGG-trix



n-EGG-rophilia

David A. Hon-EGG™



Athena Minicourses

Schedule and Index

IAP 1997

	Mon		Tue		Wed		Thu	
12 noon	6 Jan	Latex	7 Jan	Frame	8 Jan	La.Thesis	9 Jan	Fr. Thesis
7 p.m.		Latex		Frame		Latex		Frame
8 p.m.		Latex Thesis		Frame Thesis		Latex Thesis		Frame Thesis
12 noon	13 Jan	Intro	14 Jan	BasicWP	15 Jan	Working	16 Jan	EZ
7 p.m.		Intro		Working		Frame		Latex
8 p.m.		Basic WP		EZ		Frame Thesis		Latex Thesis
12 noon	20 Jan	Holiday *	21 Jan	MSO	22 Jan	Matlab	23 Jan	Maple
7 p.m.		✓ No Classes		MSO		Matlab		Maple
8 p.m.		MLK Day		Matlab		Maple		Xess
12 noon	27 Jan	Frame	28 Jan	Latex	29 Jan	Fr. Thesis	30 Jan	La. Thesis
7 p.m.		Serious Emacs		Serious Emacs		Info Res		Info Res
8 p.m.		Dotfiles		Dotfiles		HTML		HTML

IAP is a great time to learn about Athena!

These are the courses you've been meaning to get to:

- **HTML:** Learn to create Your Own WWW Pages,
- **FRAME, LATEX:** Decide how you're going to Do Your Thesis,
- **DOTFILES:** Learn the Secrets of the Customized Athena Log-in, and more!

Beginners: the week of January 20th gives you day and evening chances to take the introductory sequence: **INTRO**, **BASIC WORD PROCESSING**, and **WORKING ON ATHENA**.

- For course descriptions, see <http://web.mit.edu/minidev/www/>
- All minicourses are taught in **Room 3-343**.
- Minicourses are one hour each.

☛ **HOW TO REGISTER FOR A MINICOURSE:** You Can't! They're free -- No Pre-registration Needed... **JUST SHOW UP FOR THE CLASS.**

Bill Gates'* Christmas List:

"Is This The Way To Baker House?" A Compendium of MIT Hacking Lore This enthralling new anthology offers the most in-depth look at the hacking phenomenon ever published. \$19.95

Stud Muffins of Science 1997 Wall Calendar No, this isn't a hack—it's a real calendar! Each month features a different science hunk—all with Ph.D.'s—at work and at play. \$12.95

Forkchops A cosmic merger of forks and knives and chopsticks, Forkchops combine ingenuity, practicality, and hip design. Available in basic black or candy apple red. One pair: \$4.95. Four pair set: \$18.95.

MIT Nerd Pride™ Pocket Protector The latest in retro-nerd fashion features red block letters on the finest white vinyl. \$1.25

THE MIT MUSEUM SHOP

265 Mass. Ave. & Student Center

Don't forget to ask for your stochastically generated discount!!!

* Needless to say the Bill Gates mentioned in this ad is not the fabulously wealthy software tycoon who has a battalion of powerful lawyers at his disposal. It's some other guy. No, really.

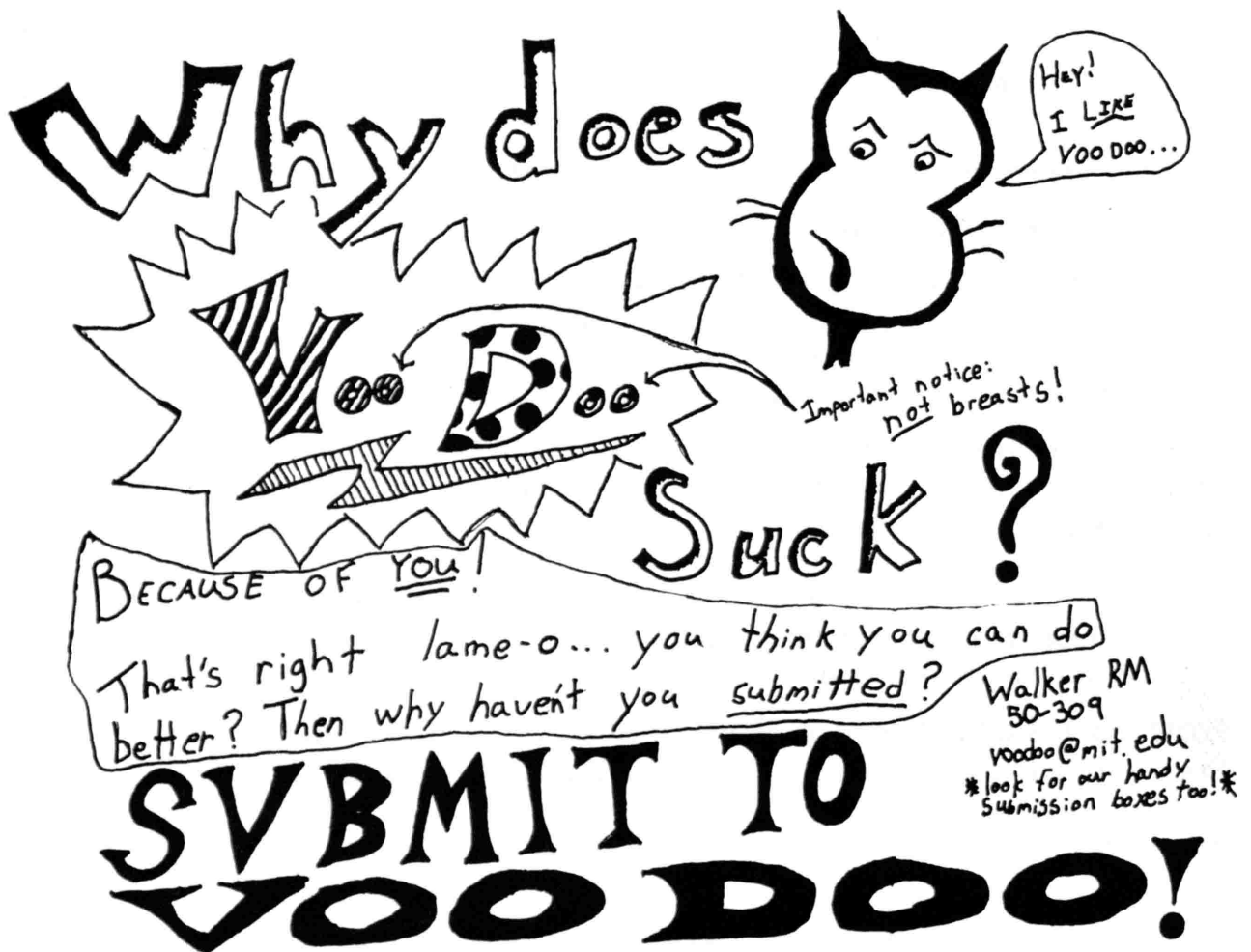

The Graduate Student Council's Little Ad

(a.k.a. sometimes the funniest thing in this crazy magazine!)

- NOV. 12 HOUSING AND COMMUNITY AFFAIRS MEETING
- NOV. 13 ACTIVITIES MEETING
- NOV. 15 FRIDAY SOCIAL
- NOV. 18 CAREER ASST. REDESIGN TEAM FOCUS GROUP
- NOV. 19 BUDGET PRIORITIES MEETING
- NOV. 21 ACADEMIC PROJECTS AND POLICY MEETING
- NOV. 23 OUTLET SHOPPING TRIP TO KITTEERY, MAINE
- DEC. 8 BOSTON BALLET'S NUTCRACKER
- DEC. 13-15 THREE-DAY SKI TRIP TO SMUGGLER'S NOTCH



Moo-ve yourself on over to the GSC office and see all the fun you've been missing out on!

From the home office in Walker Memorial, the top 10 reasons NOT to be on the Graduate Student Council:

10) Thought "GSC" stood for "Go Swimming in the Charles."

9) Haven't showered since classes started, so you don't want to meet people.

8) Filthy rich, so you don't want free food.

7) Rather spend your hour of free time watching *Baywatch*.

6) Too busy getting a tan from your monitor radiation.

5) Think everything is perfect at MIT.

4) MIT administration always makes the right decisions all by itself.

3) Not affected by any of these decisions, anyway.

2) Rather have the politicians and other resume-padders express your opinion to the administration.

1) You didn't go to grad orientation, don't have ACUS long distance, won't be looking for a job, will never face research ethics questions, never use SafeRide, don't like cultural outings, never ride the grocery shuttle, don't want student discounts, don't go on Nights on the Town, don't go hiking or skiing, and never benefit from anything we do.

**The electronic age...angelizes man,
disembodies him. Turns him into
software. — Marshall McLuhan**

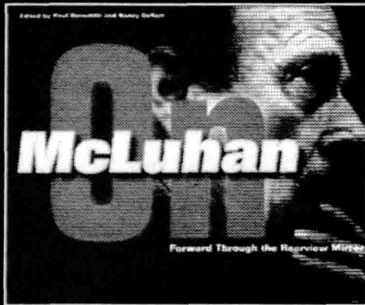

Forward Through the Rearview Mirror

Reflections on and by Marshall McLuhan
edited by Paul Benedetti and Nancy DeHart

Part book, part magazine, part storyboard, this is a multidimensional look at the ideas and life of the patron saint of *Wired* magazine. *Forward Through the Rearview Mirror* consists of short prose passages, aphorisms, interviews, letters, and dialogues by McLuhan — many never before published — interwoven with biographical text by his biographer Philip Marchand and commentary by such cultural critics as Louis Rossetto, Neil Postman, and Camille Paglia. 200 photographs, lots of color \$25.00 paper

Also available

Understanding Media: The Extensions of Man

by Marshall McLuhan

\$14.95 paper



HAL's Legacy

2001's Computer as Dream and Reality

edited by David G. Stork

foreword by Arthur C. Clarke

Inspired by HAL's self-proclaimed birth date (January 12, 1997), *HAL's Legacy* reflects upon science fiction's most famous computer and explores the relationship between science fantasy and technological fact.

Profusely illustrated with color images from the film and from current research, *HAL's Legacy* provides surprising new perspectives on key moments in the film — you will never view *2001* the same way again. Contributors include: Marvin Minsky, Daniel Dennett, Raymond Kurzweil, Rosalind Picard, Donald Norman, and Stephen Wolfram.

115 illus., 50 color \$22.50 cloth

Visit the *Hal's Legacy* website <http://mitpress.mit.edu/Hal/>



The New Hacker's Dictionary

Third Edition

compiled by Eric S. Raymond

foreword and cartoons by Guy L. Steele, Jr.

This new edition of the hacker's own phenomenally successful lexicon includes more than 100 new entries and updates or revises 200 more.

[Eric Raymond is] "The Guru of Geekspeak." — *People*

\$16.50 paper

<http://mitpress.mit.edu/bookstore>

Kendall Square T
617 253.5249

The MIT Press Bookstore

292 Main Street
Cambridge, MA 02142

books@mit.edu