

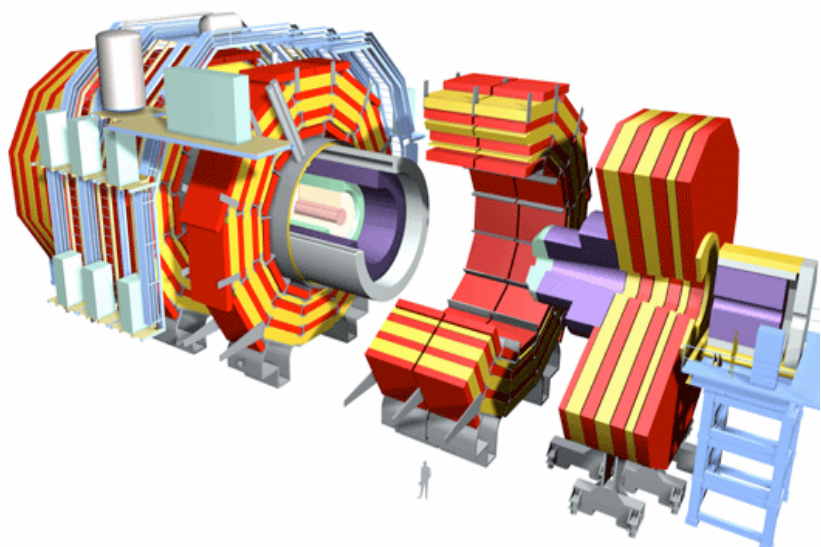

Triggering on Hard Probes in CMS

Gunther Roland

Massachusetts Institute of Technology



CMS Heavy Ion Groups: Athens, Auckland, Budapest, CERN, Chongbuk, Colorado, Cukurova, Iowa, Kansas, Korea, Los Alamos, Lyon, Maryland, Minnesota, MIT, Moscow, Mumbai, Rice, Seoul, Vanderbilt, UC Davis, UI Chicago, Yonsei, Zagreb



Compact Muon Solenoid



Forward calorimeters

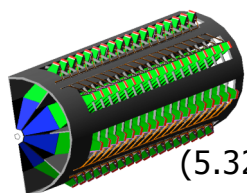

CASTOR

($5.32 < \eta < 6.86$)

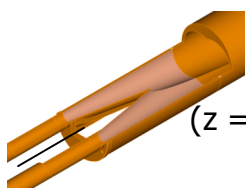

ZDC

($z = \pm 140$ m)

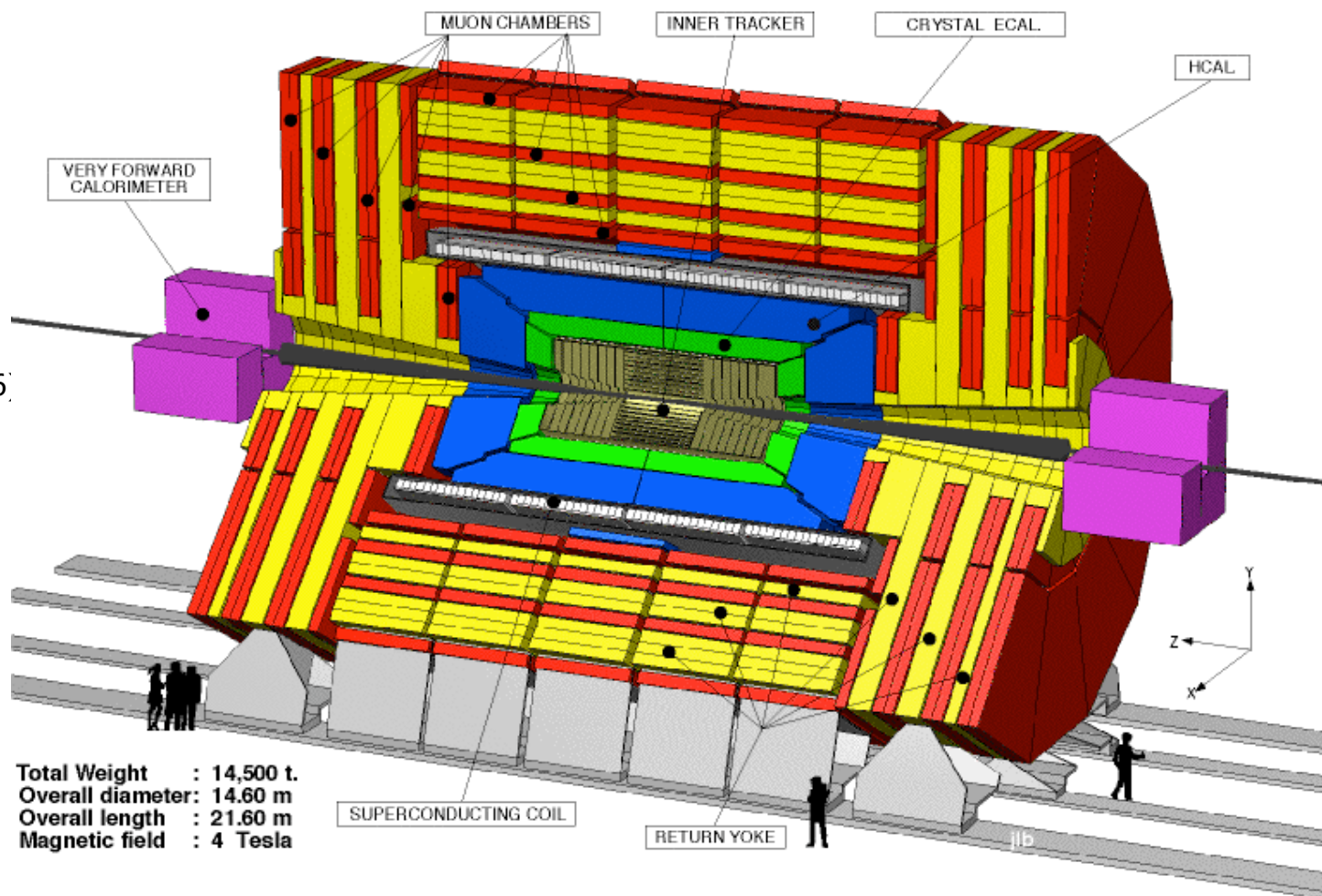

Total Weight : 14,500 t.
Overall diameter: 14.60 m
Overall length : 21.60 m
Magnetic field : 4 Tesla

One of two large p+p experiments at LHC
"Large": 2700 collaborators, \$500M, 14500 tons



CMS as a Heavy Ion Experiment

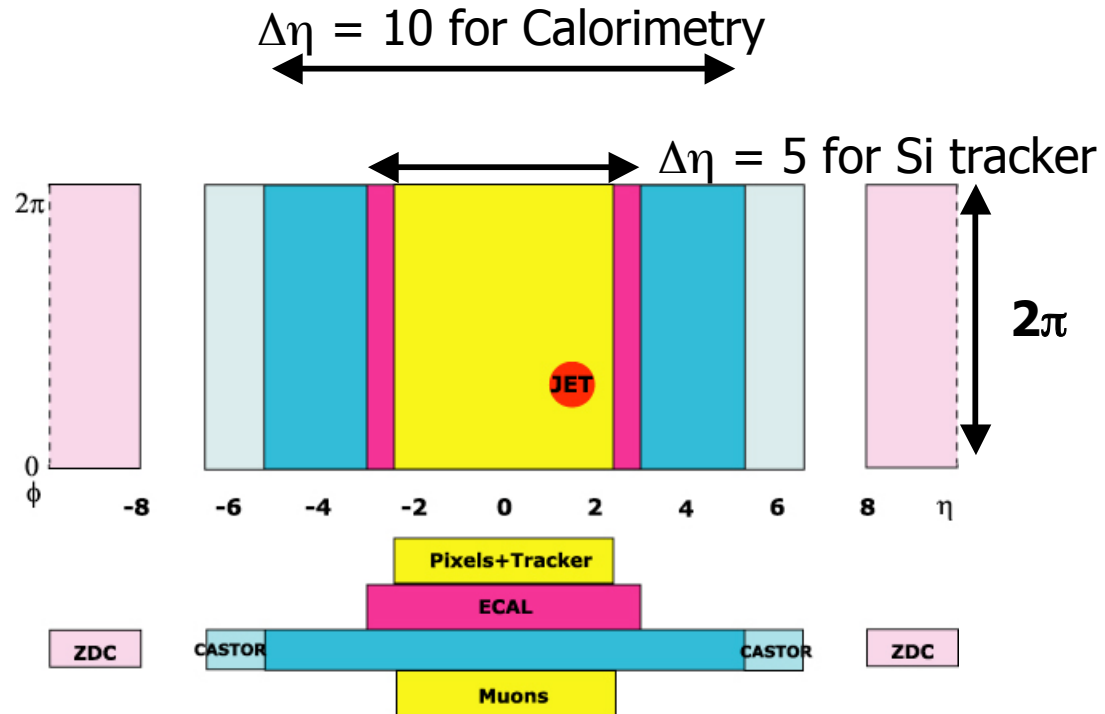
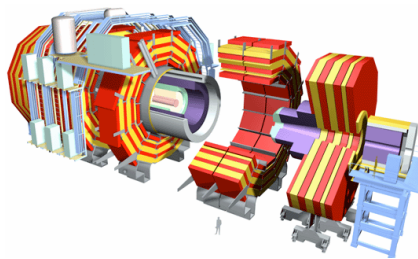

Capabilities

High Precision Tracking over $|\eta| < 2.5$
Muon Identification over $|\eta| < 2.5$
High Resolution Calorimetry over $|\eta| < 10$
Forward coverage
Large Bandwidth DAQ + Trigger

p+p DAQ&Trigger Challenge:

- 25 collisions per bunch crossing
- 40MHz bunch crossing frequency
- Rejection factor of $O(10^6)$ needed



Trigger in Pb+Pb vs pp

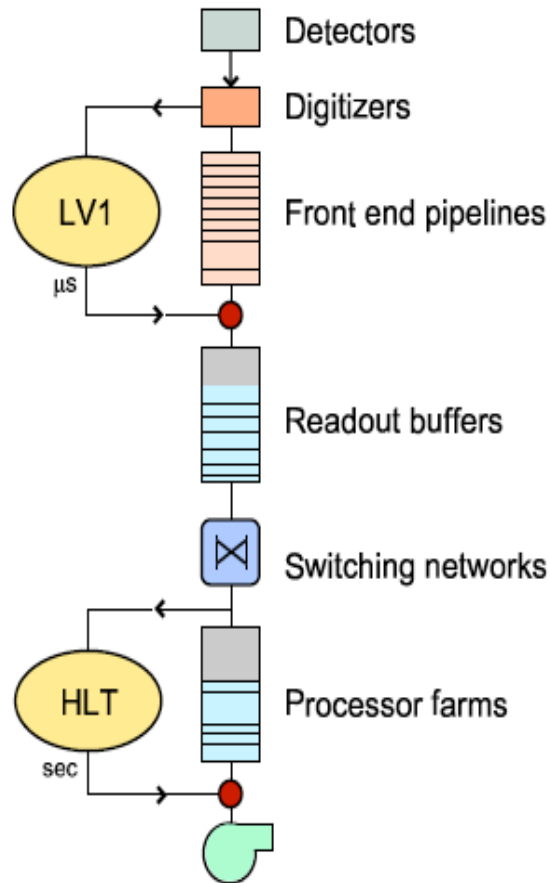

Level 1 trigger

- Uses custom hardware
- Muon chamber + calorimeter information
- Decision after $\sim 3\mu\text{sec}$

Level-1		p+p
Collision rate		1GHz
Event rate		40MHz
Output bandwidth		100 GByte/sec
Rejection		99.7%

High level Trigger

- ~ 1500 Linux servers ($\sim 12\text{k}$ CPU cores)
- Full event information available
- Runs "offline" algorithms

High Level Trigger		p+p
Input event rate		100kHz
Output bandwidth		225 MByte/sec
Output rate		150Hz
Rejection		99.85%



Trigger in Pb+Pb vs pp

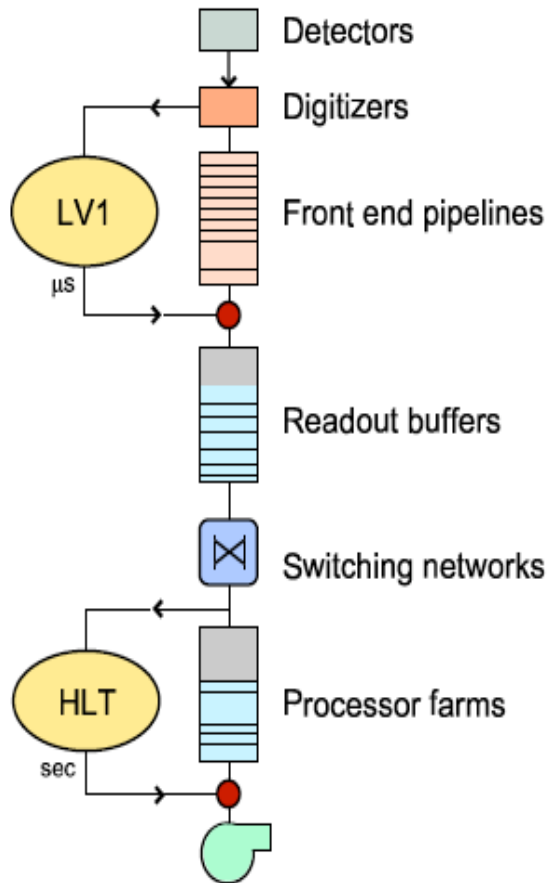

Level 1 trigger

- Uses custom hardware
- Muon chamber + calorimeter information
- Decision after $\sim 3\mu\text{sec}$

Level-1	Pb+Pb	p+p
Collision rate	3kHz (8kHz peak)	1GHz
Event rate	3kHz (8kHz peak)	40MHz
Output bandwidth	100 GByte/sec	100 GByte/sec
Rejection	none	99.7%

High level Trigger



Main "hardware" task for CMS heavy ion running

- ~ 1500 Linux servers ($\sim 12\text{k}$ CPU cores)
- Full event information available
- Runs "offline" algorithms

High Level Trigger	Pb+Pb	p+p
Input event rate	3kHz (8kHz peak)	100kHz
Output bandwidth	225 MByte/sec	225 MByte/sec
Output rate	10-100Hz	150Hz
Rejection	97-99.7%	99.85%



Heavy Ion Trigger Strategy



- **Send full min bias Pb+Pb event stream to HLT**
- **Run “offline” algorithms on every Pb+Pb event**
 - Select Hard Probes embedded in highly complex events
 - Examples: Jet finding algorithm, dimuon reconstruction
 - Best selection needs full event information, complex algorithms
- **Requirements:**
 - Sufficient DAQ bandwidth
 - 100 Gbyte/sec bandwidth
 - Sufficient CPU time budget
 - ~12k 1.8GHz Opteron equivalent CPU cores
 - 3KHz average rate, 8kHz max (**1.5-4 CPU-seconds per event**)
- **Execution time of “offline” algorithms?**



Min bias trigger from HF

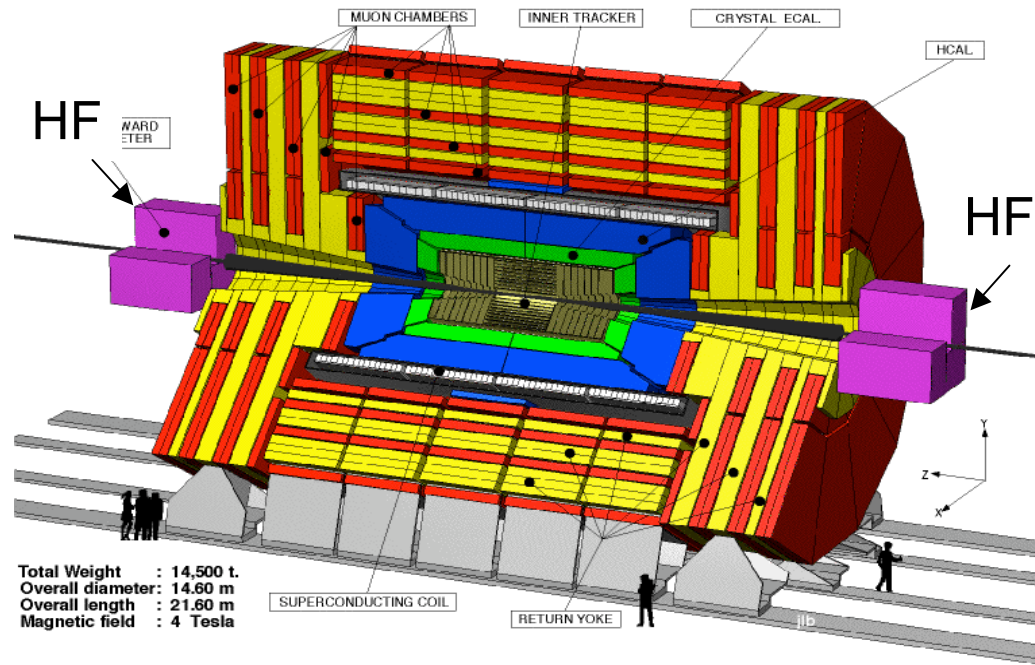

Minimum bias trigger for p+p and Pb+Pb
Forward Calorimeter (HF)
 $3.0 < |\eta| < 5.0$

Similar to PHOBOS “Paddle” trigger



Event Characterization in HLT



Single Pb+Pb event, $b=6\text{fm}$

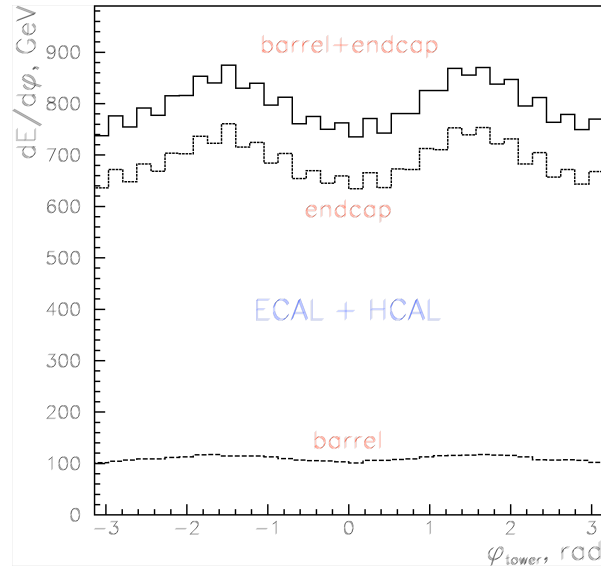

Event plane resolution
 $\sigma \sim 0.12 \text{ rad}$

Energy in HF forward calorimeter

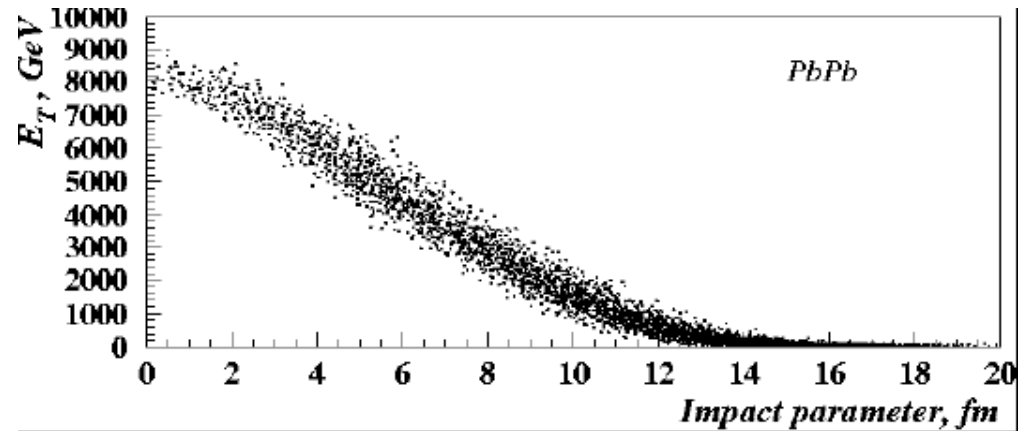

Event characterization from Calorimeters

- Centrality
- Reaction plane

calculated at High Level Trigger

**Unpacking Calo data takes $\sim 100\text{ms}$
per min bias event event**



Heavy Ion Jet Finder Performance

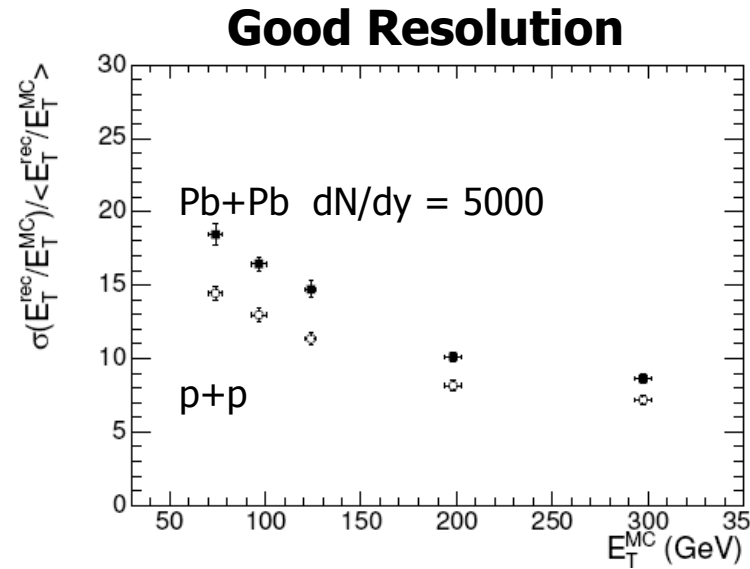
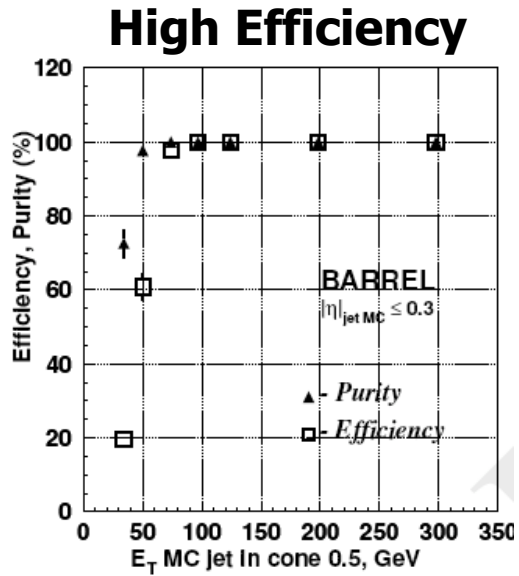

Jet studies from CMS Note 2003/004

Run offline jet finder at HLT
- modified iterative cone algorithm

Performance as shown in offline studies



Jet Finder Timing



Jet finder timing

- Full modified iterative cone with background subtraction
- Average execution time $t \sim 0.25\text{sec}$ per min bias event
- This corresponds to $\sim 5\%$ of HLT time budget

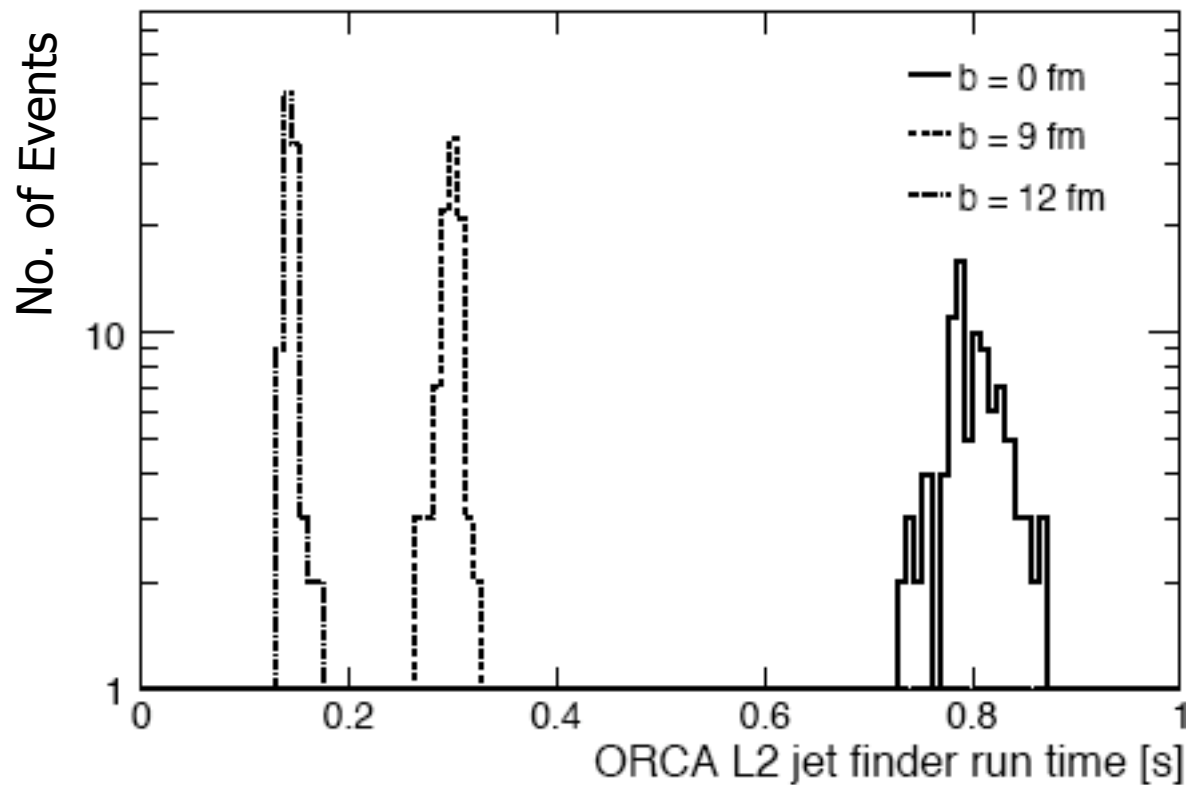



Online Muon finding

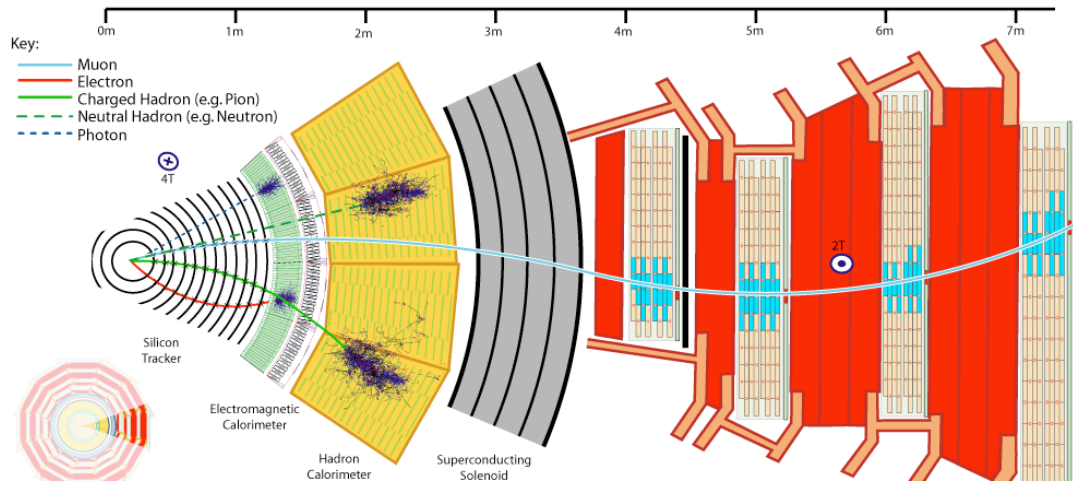

Quarkonium studies from CMS Note 2006

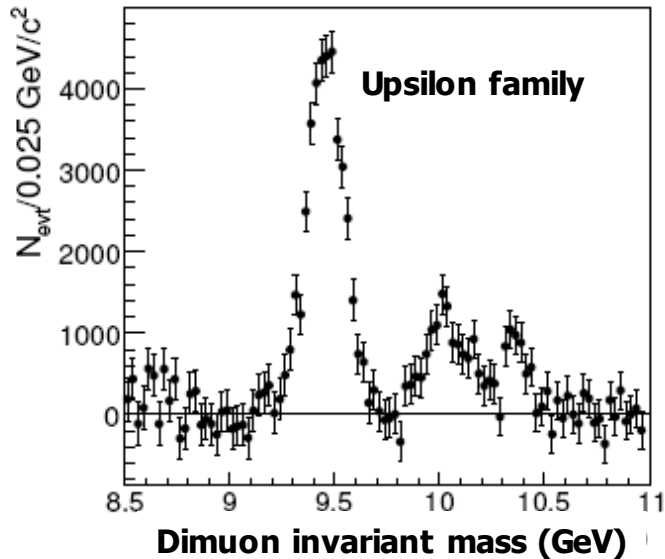

Muon finding in HLT

- L1: muon chambers stubs (Hardware)
- L2: muon chambers stubs (HLT - fast)
- L3: Match with tracker info (HLT - slow)

Performance as shown in offline studies

- Si tracker info allows resolution of upsilon family



Muon L2 timing



Timing of L2 muon finder

- Muon chamber stand-alone reconstruction
- Average $t \sim 0.1$ sec per min bias event
- $\sim 2\%$ of HLT time budget

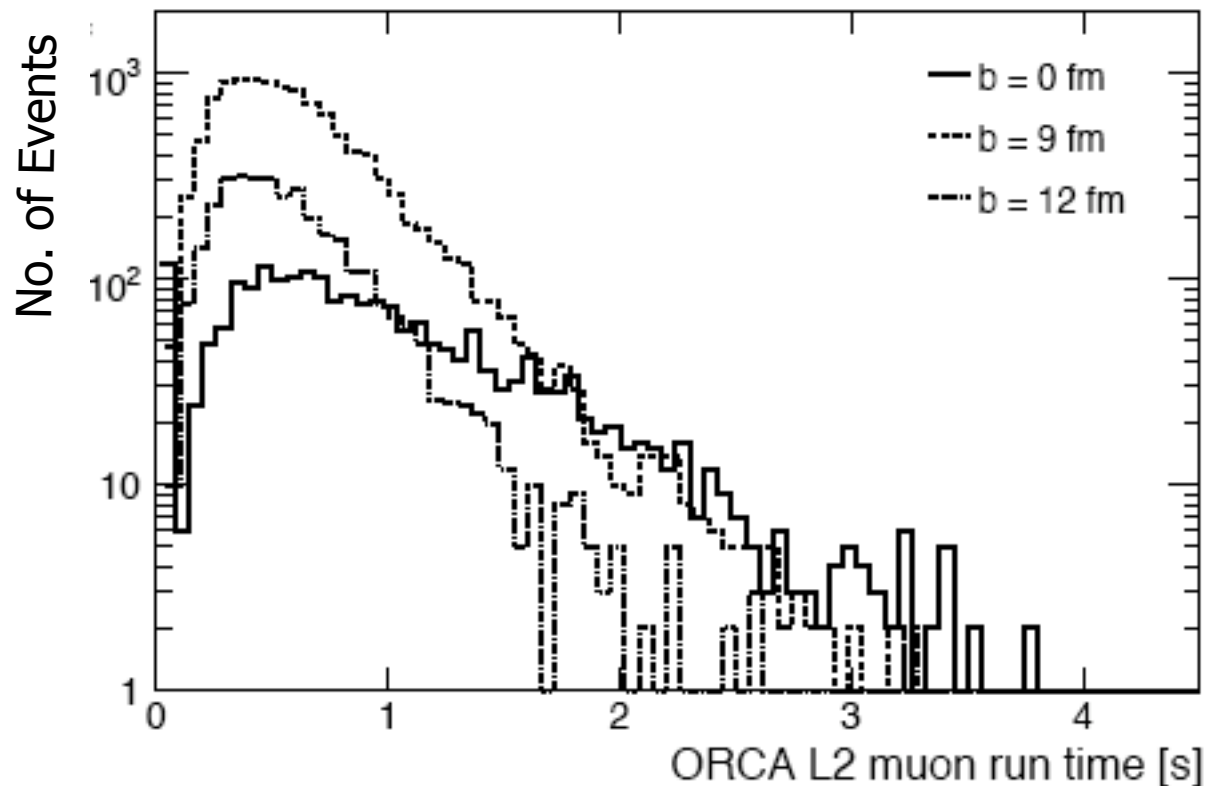



Muon L3 timing



Timing of muon L3 algorithm

- Reduces background by factor 4
- Called for 1.6% of min bias events
- Average execution time 10 +/- 3 sec
- Need speed-up by factor ~5 for design luminosity run

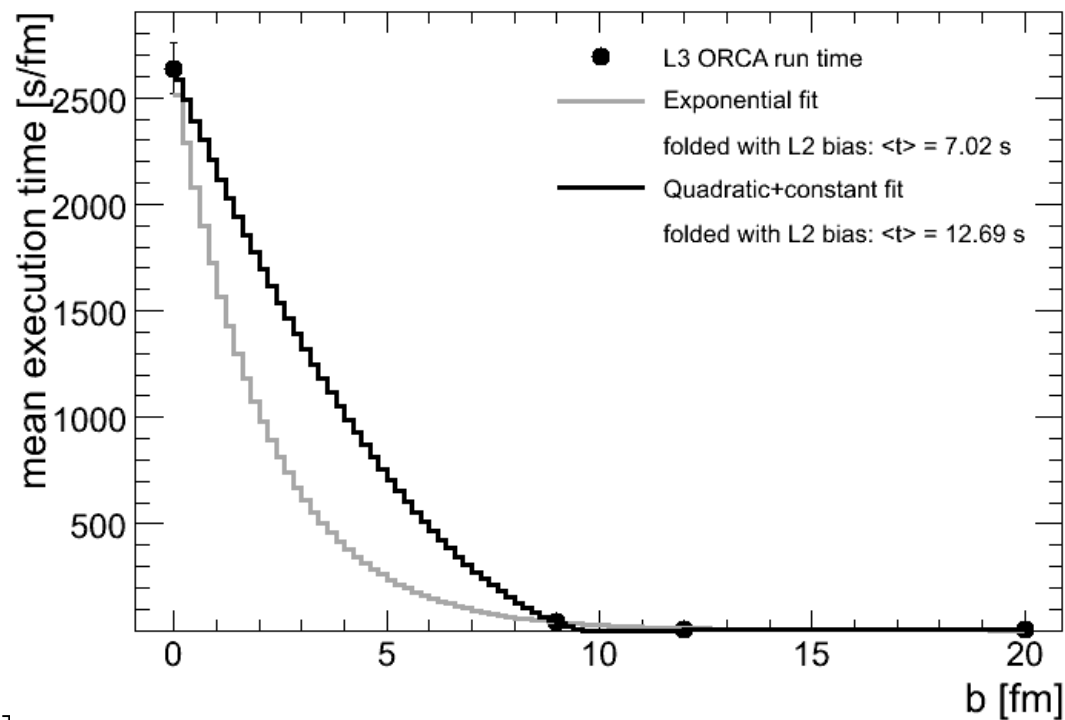



Event Size Bias



Event size bias from trigger

- Centrality bias from dimuon and jet trigger
- Increase in event-size by factor 2-3 vs min bias
- Determines rate of events to tape

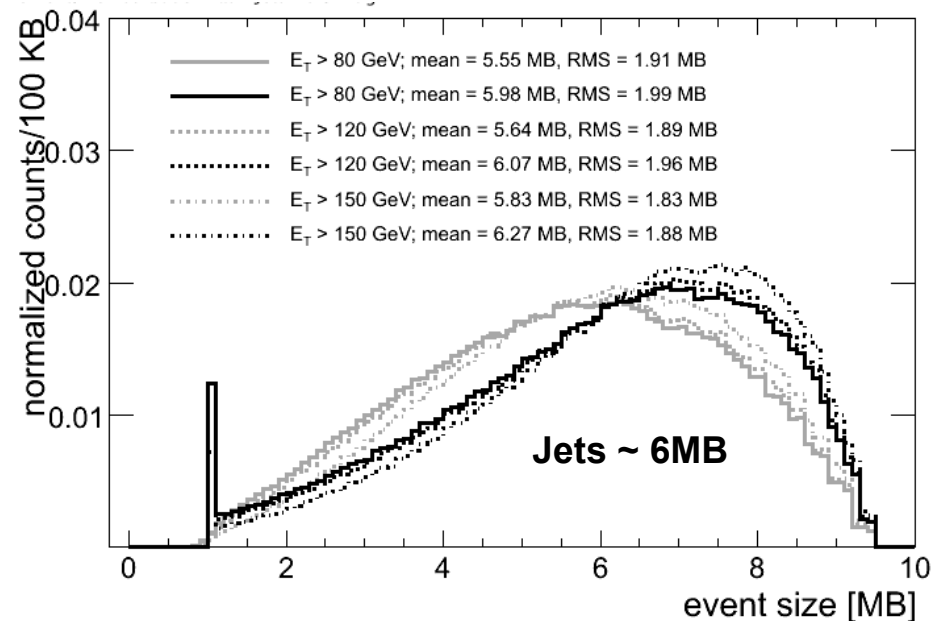
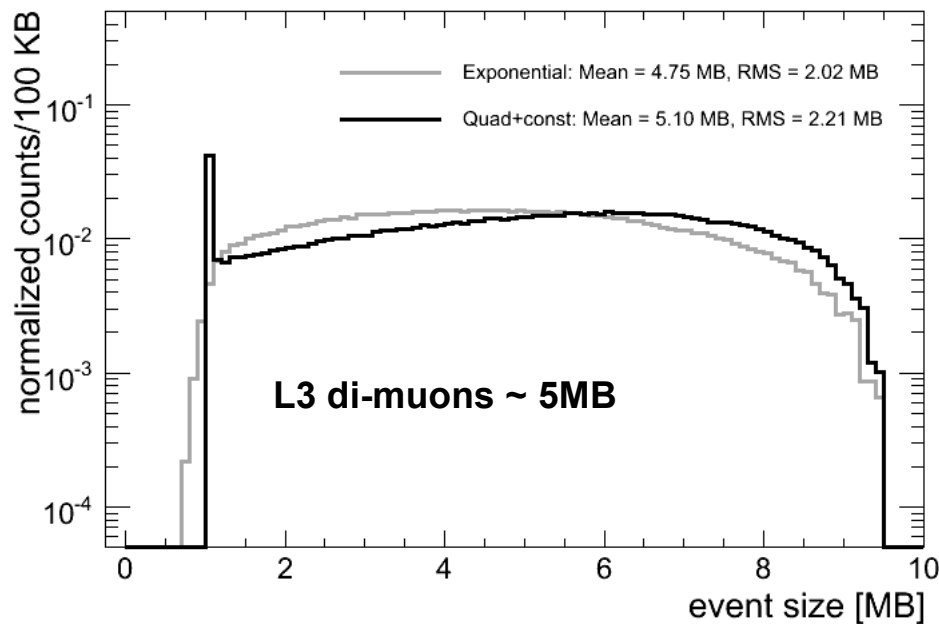



High Level Trigger Simulations



Production x-sections

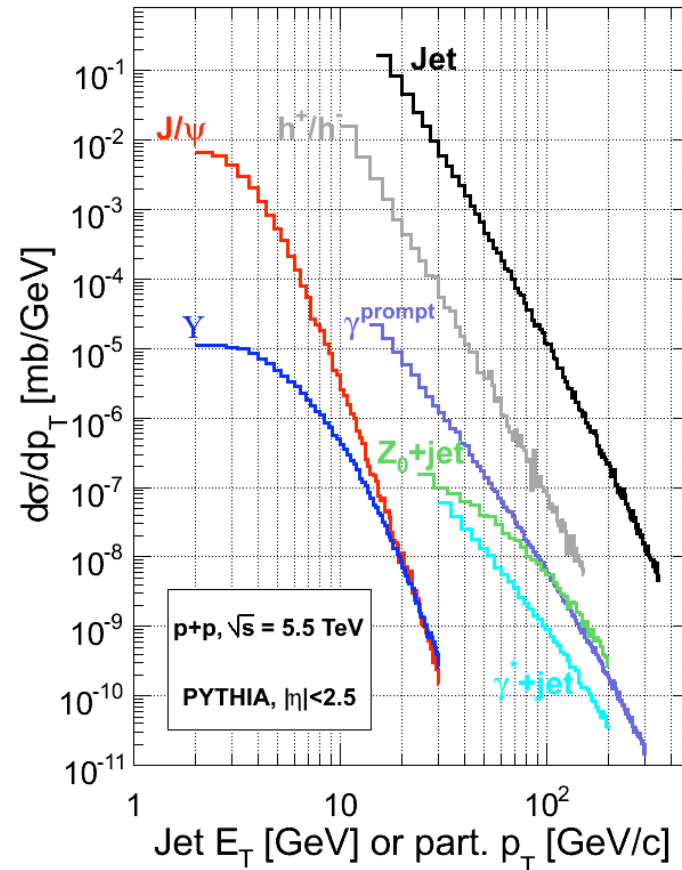

Pythia v6.236 p+p @ 5.5 TeV
No nuclear effects
 $|\eta| < 2.5$

**Study enhancement in physics reach
provided by HLT vs min bias**

Example based on Pythia p+p production cross-sections



High Level Trigger Simulations

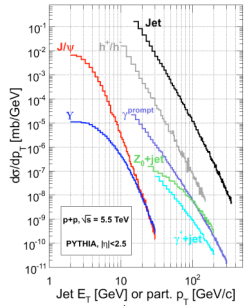

Production X-sections

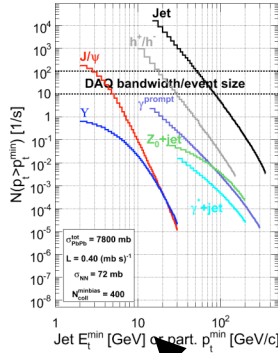

Acceptance, efficiency, backgrounds measured and parametrized from full offline simulation + algorithms

$$d^2\sigma/dydp_T \otimes \text{Luminosity} \otimes N_{coll} \rightarrow \text{Production rate}$$

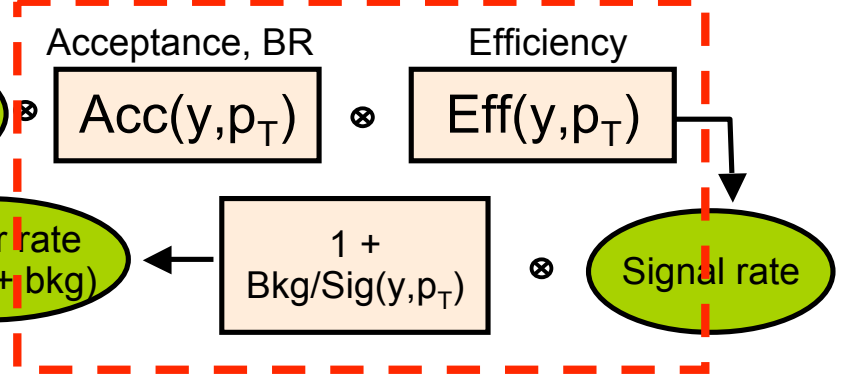

Rate to tape

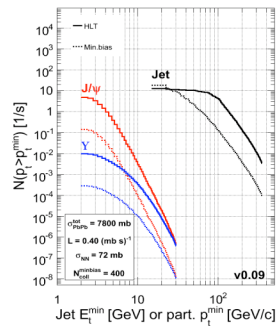

Output Rates to tape

Trigger table, using event size bias measured on full simulations



Trigger table



Strawman trigger table for design lumi (v0.09)

Channel	Threshold	Prescale	Bandwidth [MByte/s]	Event size [MByte]
min. bias	–	220	33.75 (15%)	2.5
jet	100 GeV	1	24.75 (11%)	5.8
jet	75 GeV	3	27 (12%)	5.7
jet	50 GeV	25	27 (12%)	5.4
J/ψ	0 GeV/c	1	67.5 (30%)	4.9
Υ	0 GeV/c	1	2.25 (1%)	4.9
γ^{prompt}	10 GeV	1	40.5 (18%)	5.8
UPC/forward coll.	–	1	2.25 (1%)	1

Many more channels to be added, in particular multi-object triggers (e.g. dimuons + jets)

Prescales and thresholds can be adjusted as function of e.g. centrality and instantaneous luminosity



Physics Reach HLT vs Min Bias

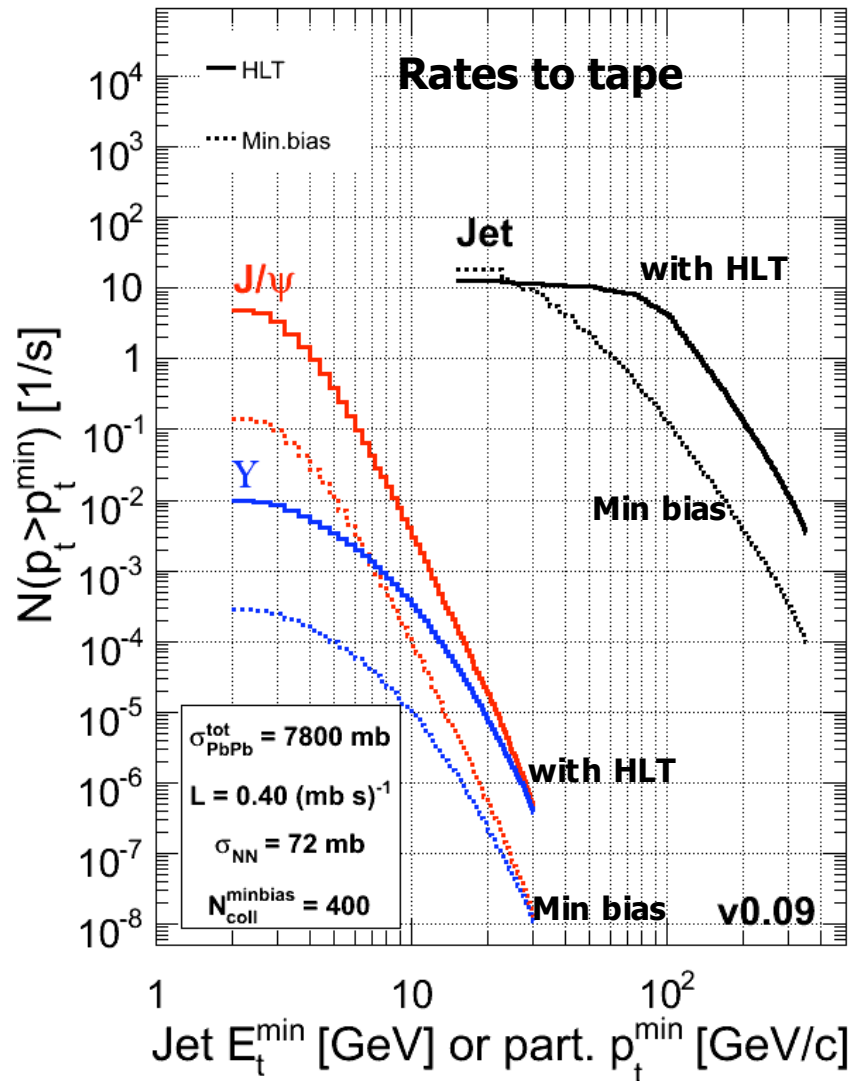

HLT improves hard probe statistics by more than factor 10

Expect that jet trigger will increase range for charged hadron R_{AA} by more than factor 2 (to $\sim 200 \text{ GeV}/c$)

Centrality info at HLT important for improving R_{CP} via centrality dependent prescales and thresholds

Note: HLT rates only counted within respective trigger channel



Physics example - Y'/Y vs p_T

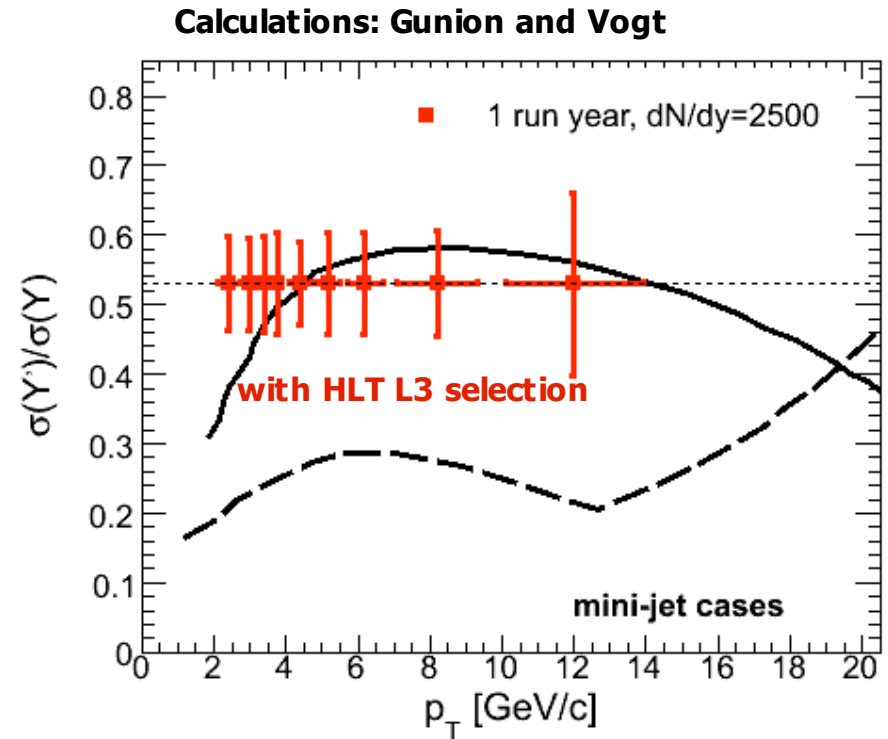
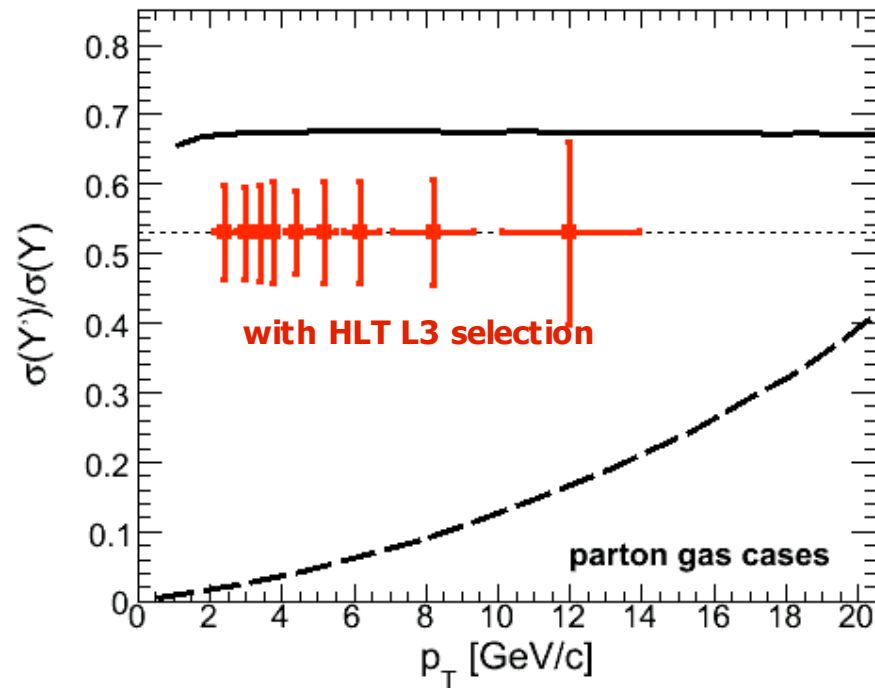

**Detailed studies of Upsilon family
feasible with HLT**

N.B. errors for min bias ratio would be off plots

(10^6 sec @ design lumi)



a kind of summary...



Global	Tracking	Calorimetry	Muons
Centrality HF, ZDC	$d^3N/dp_T d\eta d\phi$ Inner Tracker $ \eta < 2.5, p_T > 1 \text{ GeV/c}$	Central Jets EB, EE, HB, HE $N > 10^7$ $ \eta < 2.5, E_T > 50 \text{ GeV}$	Single muons MB, ME $ \eta < 2.4, p > 3 \text{ GeV/c}$
Reaction Plane HF, EE, HE $\sigma_{EP} < 0.1 \text{ Rad}$	Primary vertex Inner Tracker $\sigma_{vtx} < 10 \mu\text{m}$	Forward Jets HF $3 < \eta < 5$	J/ψ MB, ME $N > 10^5$ $ \eta < 2.4, p_T > 1..3 \text{ GeV/c}$
Mult. $d^2N/d\eta d\phi$ Inner tracker, Totem $ \eta < 2.5 (7-10)$	Sec. vertex tag Inner Tracker $\sigma_{vtx} \sim 100 - 10 \mu\text{m}$	π^0 $d^3N/dp_T d\eta d\phi$ EB, EE $ \eta < 2.5, 3 < p_T < 20 \text{ GeV}$	$\Upsilon, \Upsilon', \Upsilon''$ MB, ME $N > 20\text{k}$ $ \eta < 2.4, p_T > 0 \text{ GeV/c}$
E_T flow $d^2E_T/d\eta d\phi$ EB, EE, HB, HE, HF Castor, ZDC $ \eta < 7 (10)$		Photons EB, EE $ \eta < 3.0$	Z^0 MB, ME $N > 10\text{k}$ $ \eta < 2.4, p_T > 0 \text{ GeV/c}$
		Electrons EB, EE $ \eta < 3.0$	γ^* MB, ME $ \eta < 2.4$



= to be investigated



a kind of summary...



Global	Tracking	Calorimetry	Muons
Centrality HF, ZDC	$d^3N/dp_T d\eta d\phi$ Inner Tracker $ \eta < 2.5, p_T > 1 \text{ GeV/c}$	Central Jets EB, EE, HB, HE $N > 10^7$ $ \eta < 2.5, E_T > 50 \text{ GeV}$	Single muons MB, ME $ \eta < 2.4, p > 3 \text{ GeV/c}$
Reaction Plane HF, EE, HE $\sigma_{EP} < 0.1 \text{ Rad}$	Primary vertex Inner Tracker $\sigma_{vtx} < 10 \mu\text{m}$	Forward Jets HF $3 < \eta < 5$	J/ψ MB, ME $N > 10^5$ $ \eta < 2.4, p_T > 1..3 \text{ GeV/c}$
Mult. $d^2N/d\eta d\phi$ Inner tracker, Totem $ \eta < 2.5 (7-10)$	Sec. vertex tag Inner Tracker $\sigma_{vtx} \sim 100 - 10 \mu\text{m}$	$\pi^0 d^3N/dp_T d\eta d\phi$ EB, EE $ \eta < 2.5, 3 < p_T < 20 \text{ GeV}$	Y, Y', Y'' MB, ME $N > 20k$ $ \eta < 2.4, p_T > 0 \text{ GeV/c}$
E_T flow $d^2E_T/d\eta d\phi$ EB, EE, HB, HE, HF Castor, ZDC $ \eta < 7 (10)$		Photons EB, EE $ \eta < 3.0$	Z^0 MB, ME $N > 10k$ $ \eta < 2.4, p_T > 0 \text{ GeV/c}$
		Electrons EB, EE $ \eta < 3.0$	γ^* MB, ME $ \eta < 2.4$

Photons
EB,EE
 $|\eta| < 3.0$

Electrons
EB,EE
 $|\eta| < 3.0$

Most physics info available at HLT

**Allows optimal use of bandwidth w/
best efficiency and minimal bias**



= available at HLT

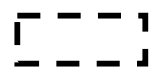

= to be investigated



Additional info



Data Samples



- **Centrally produced fully simulated Heavy Ion Events (OSCAR 3.9.8 / ORCA 8.7.3)**
- **Signal: Pythia multijet (unquenched)**
- **Background: Hydjet events**
 - hi05_hydjet_x0_bB_pt07 with $B = 0, 9, 12$
- **Used for size and jet, di-muon timing studies**



CMS DAQ Design

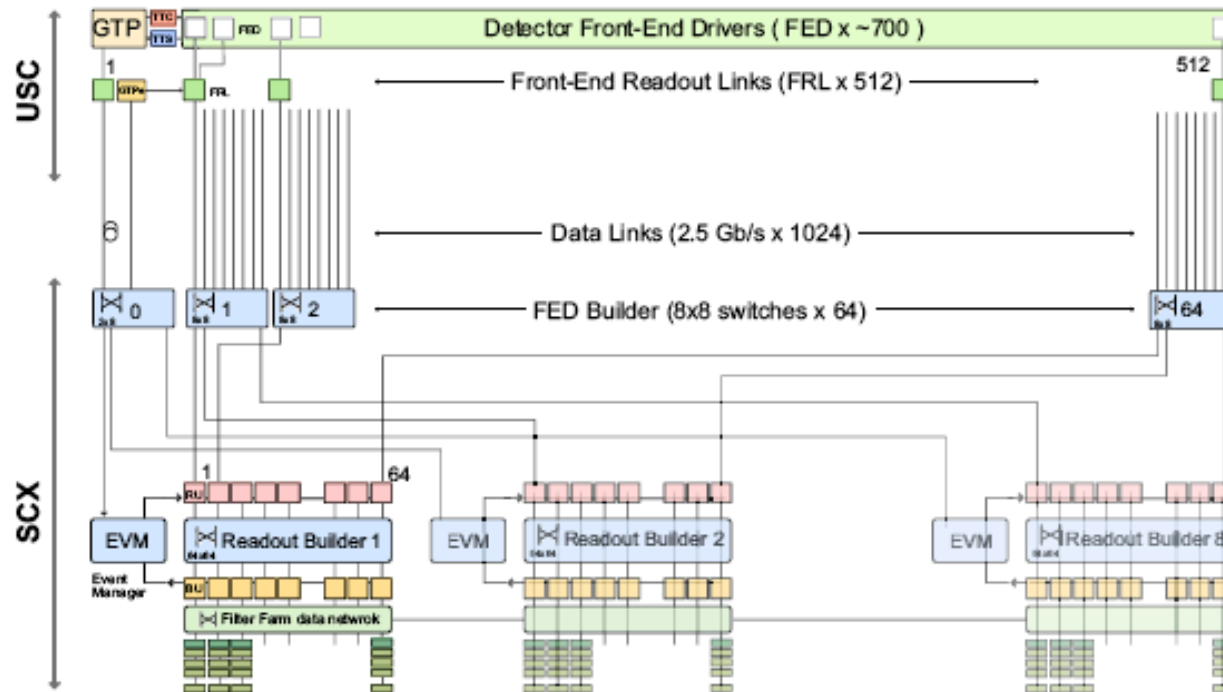

Figure 1: Sketch of the CMS DAQ system.

Figure 1 shows a simplified sketch of the CMS DAQ system. The data flow is from top to bottom in the figure. At the top are drawn the detector Front-End Drivers (FEDs) from which data are read into the 512 Front-End Readout Links (FRLs) that are able to merge the data of up to four FEDs together. The outputs of 8 FRLs are then pre-assembled in the FED builder and data are sent to one or more Readout Builders (RU Builder slices). The RU Builders are independent systems in charge of building the full events, performing the physics selections and forwarding the selected events to mass storage. The number of RU Builders in the system will grow up to 8 at the design luminosity of $10^{34} \text{ cm}^{-2} \text{ sec}^{-1}$ that will be reached after a couple of years from the start-up. Figure 2 shows a larger picture of one slice of the RU Builder and indicates its various components. In the baseline configuration a RU Builder is made up by 64 Readout Units (RU) and 64 Builder Units (BU) connected together by a switching network. An Event Manager (EVM) supervises the data flow in the RU Builder. From the BUs all events are sent to the Filter Units (FU) through another switching network, the Filter Data Network (FDN). In the baseline configuration the number of FUs per RU Builder is 256.



Event Size Study



- **For each b , digitized the mixed events using ORCA 8.13.3 using example production config**
- **Write DIGI files for 10 and 40 events**
- **Use file sizes and the particle and hit counts from log files to estimate differential event size**
- **Estimate base (empty) event size from this data and known pp event size**



CMS Readout Builder Slice

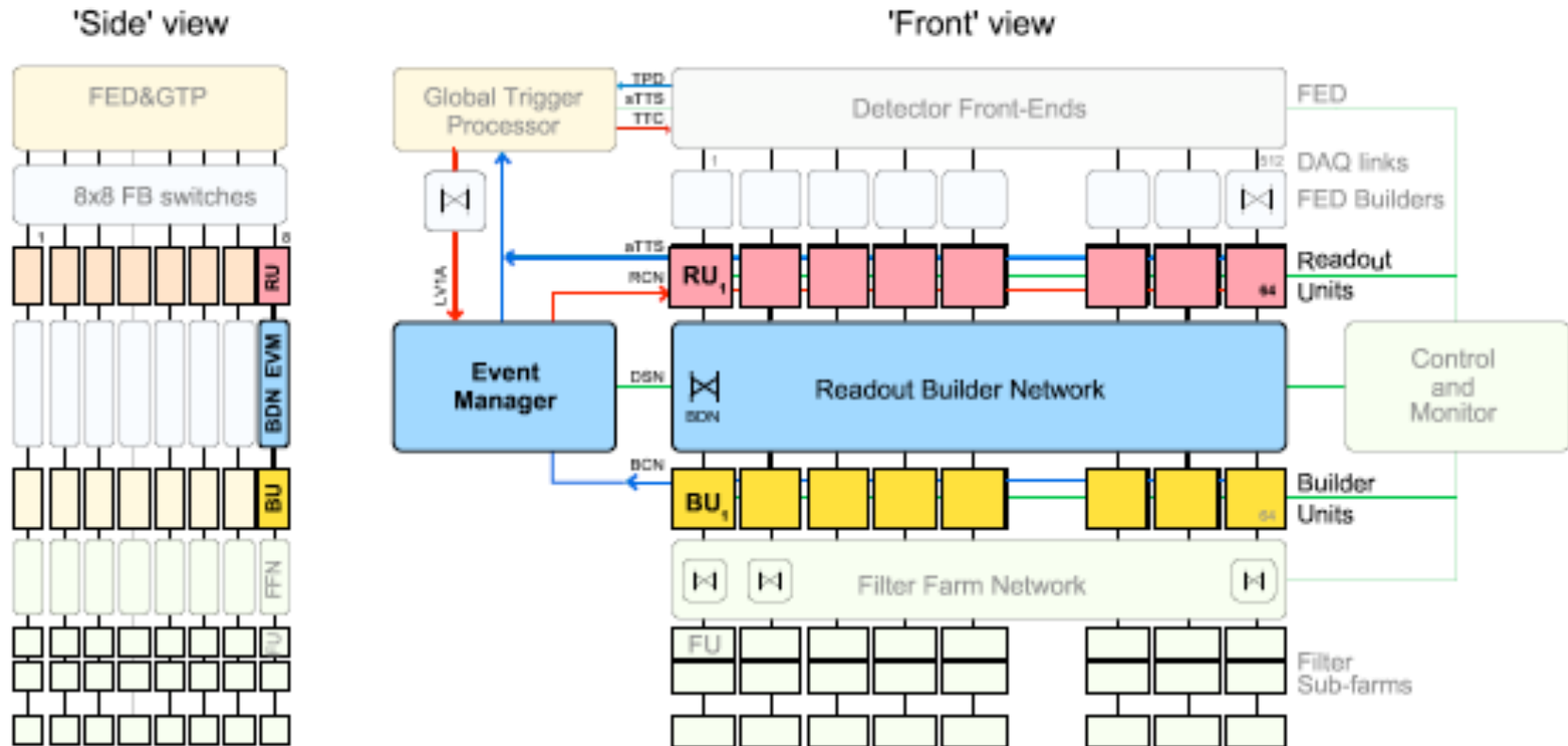



Timing Study – Jet Finder



- **ORCA 8.13.3, Pileup subtraction jet finder**
 - CMS AN 2003-004 : V. Gavrilov, O. Kodolova, A. Oulianov, I. Vardanian
 - Used the implementation by C. Roland
- **Used COBRA TimeMe framework and ROOT TstopWatch**
 - Records time spent in a part of the code and the number of invocations, creates average timings
 - Add extra timers to study timing of different parts of the algorithm



Event size in Pb+Pb vs p+p



- **Total “fudge factor” of 5 for initial p+p run**
- **But: “Factor” is really combination of offset+factor**
 - Don’t expect zero-suppression, HLT info, occupancy factor to be proportional to soft particle multiplicity
 - Rather than guess shift/factor for every contribution, we added 2 x p+p “extra size” to Pb+Pb for initial and steady-state runs (2MB, 1MB)
- **Worst case: What if it really is a factor of 5?**
 - dN_{ch}/dy for min bias Pb+Pb < 1000 compared to 20x7 for design lumi p+p at 14TeV
 - I.e. <7x more particles at mid-y, but >12x less rate than p+p (8kHz vs 100kHz)
 - Still ok relative to p+p



Timing Study – Di-muon trigger



- **ORCA 8.13.3 with Heavy Ion di-muon trigger**
 - CMS AN 2006-011 M. Bedjidian, O. Kodolova
 - Implementation provided by O. Kodolova
- **Used COBRA TimeMe framework**
- **Added many extra timers and trace output**
- **Measured Level 1 selectivity and Level 2 timing and selectivity**
- **Measured L3 timing**



Event size in Pb+Pb vs p+p



Requirement: The RAW event size *at startup* is estimated to be $S_{RAW} \simeq 1.5$ MB, assuming a luminosity of $\mathcal{L} = 2 \times 10^{33} \text{cm}^{-2}\text{s}^{-1}$.
R-2

This was obtained as follows: 0-suppression ← HLT-objects

$$S_{RAW} = 300\text{kB} \times F_{Det} \times F_{HLT} \times F_{MC} \simeq 300\text{kB} \times 2.5 \times 1.25 \times 1.6$$
$$\simeq 1.5 \text{ MB/event}$$

← MC vs real occupancy

Hopefully these factors will drop quite quickly after a few months (as for CDF) and then steadily asymptote towards unity after some years of experience. It should be noted that at this period one is also trying to time-in the various sub-detectors and overall size is not the main concern. After this initial period, as the detector is more-or-less commissioned, and one is mainly debugging the HLT:

$$S_{RAW} = 300\text{kB} \times F_{HLT} \times F_{MC} \simeq 300\text{kB} \times 1.25 \times 1.6$$
$$\simeq 600 \text{ kB/event}$$

This period lasted in CDF more than a year. When the HLT is validated one can reach the projected steady-state event size for low luminosity of:

$$S_{RAW} = 300\text{kB} \times F_{MC} \simeq 300\text{kB} \times 1.6$$
$$\simeq 500 \text{ kB/event}$$

From Computing RTAG: CMS-Note 2004/031

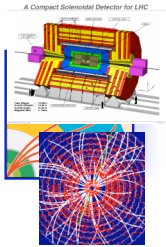

CMS detector: L=21.6m, D=14.6m, weight=12500tons

Time between bunch crossings: 25 ns (pp)

Event rate: 10^9 events/s (pp)

B

Magnetic field: 4T (L=13m, D_{in} =5.9m)

Silicon tracker: L=5.8m, D_{in} =2.6m, thickness=320, 500 μ m, operating T=-20 $^{\circ}$ C

Pixel: 3 barrel (768 modules) and 2 endcap (672 modules) layers, S_{tot} =1m 2 , R_{barrel} =4.4, 7.3, 10.2cm, Z_{endcap} =34.5, 46.5cm, S_{pix} =100x150 μ m 2 , occupancy 10^{-4} (pp) – 1%(PbPb), single point resolution 10 μ m in r-f and 20 μ m in z direction

Silicon strip: 10 barrel and 9 endcap layers, S_{tot} =200m 2 , 15,400 modules

Inner silicon strip: R=20-55cm, S=10cm x 80-120nm, occupancy 2-3% , single point resolution 23-34 μ m in r-f and 230 μ m in z direction

Outer silicon strip: R>55cm, S=25cm x 180 μ m, occupancy 1%(pp)-20%(PbPb) , single point resolution 35-52 μ m in r-f and 530 μ m in z direction

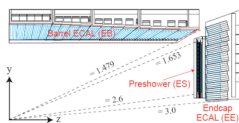
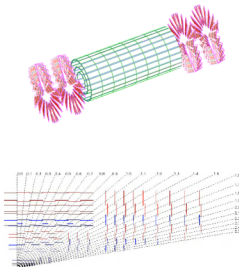

EM calorimeter: homogeneous PbW O_4 crystals, $|\eta|<3.0$, thickness $\sim 25 X_0$

Resolution: S=3.63 \pm 0.1%, N=124MeV, C=0.26 \pm 0.01%.

$$\left(\frac{\sigma}{E}\right)^2 = \left(\frac{S}{\sqrt{E}}\right)^2 + \left(\frac{N}{E}\right)^2 + C^2$$

Barrel: 61200 crystals, $|\eta|<1.479$, R_{in} =129cm, 22x22x230 mm 3 , 25.8 X_0

Endcaps: 7324 crystals in each endcap, 1.479< $|\eta|$ <3.0, 28.6x28.6x220 mm 3 , 24.7 X_0

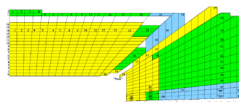

Hadron calorimeter: sampling brass/scintillator, $|\eta|<3.0$, thickness 7-11 l_1

Hadron barrel: $|\eta|<1.4$, 2304 towers ($\Delta\eta \times \Delta\phi$ =0.087x0.087)

Hadron outer calorimeter: inside muon system, $|\eta|<1.26$

Hadron endcap: 1.3< $|\eta|$ <3.0, 2304 towers (0.087-0.35 η segmentation, 5-10 0 ϕ segmentation)

Hadron forward: iron/quartz-fibre Cherenkov, 3.0< $|\eta|$ <5.0, 900 towers ($\Delta\eta \times \Delta\phi$ =0.175-0.3x10-20 0)

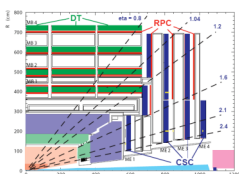

Muon system: $|h|<2.4$, S>25,000m 2 , $\sim 10^6$ electronic channels

Barrel: 250 chambers in 4 layers R=4.0m, 4.9m, 5.9m, 7.0m, Single point resolution: $\sim 200 \mu$ m, space and direction resolution along f -angle <100nm and ~ 1 mrad.

Endcap: 468 CSCs, Single point resolution 100-200 μ m, direction resolution along ϕ -angle 10mrad.



Trigger Quality: beam gas rejection



- **Beam-Gas Rejection**

- Gas pressure\$ is expected to be low
- For p+p collisions at 14TeV, only 20* beam gas events per hour are expected
 - Expectations and truth do not always match, we have a contingency
- Pb(5.5TeV)+gas collisions are $\sqrt{s_{NN}} \sim 100\text{GeV}$
 - All particles go forward

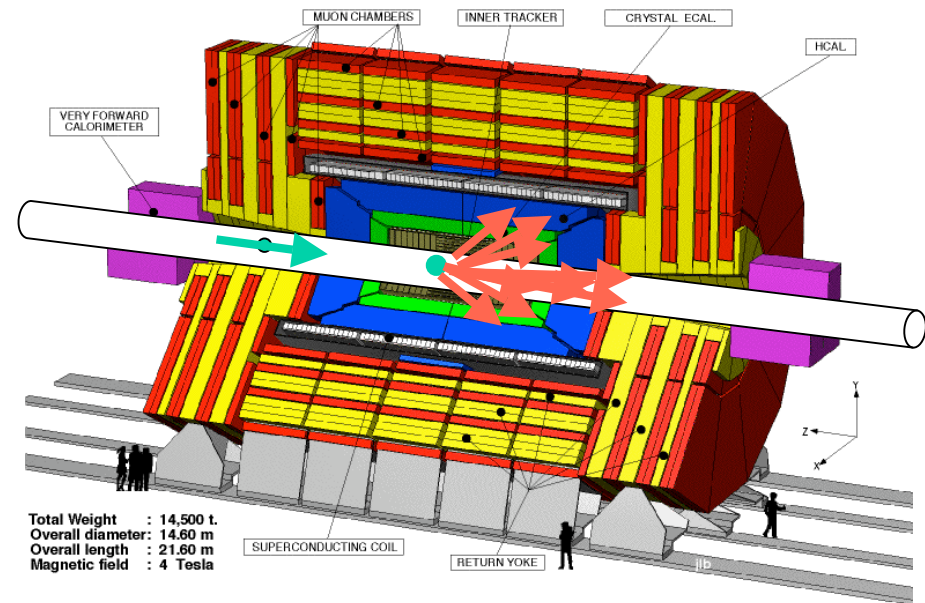

For beam-gas inside the detector Volume triggering on HF will remove these from the data

\$ 10⁻¹¹ Torr: cf 10⁻¹⁰ at RHIC (warm sections)
Proc. 2003 Particle accelerator conference

* From the LHC machine working group



Trigger Quality: beam gas rejection

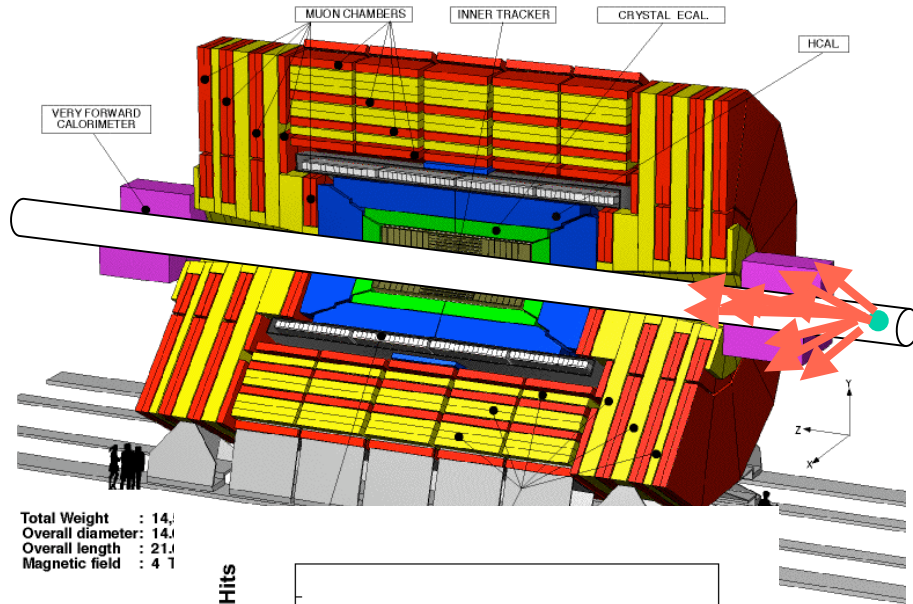

Total Weight : 14,000 t
Overall diameter : 14.6 m
Overall length : 21.9 m
Magnetic field : 4 T

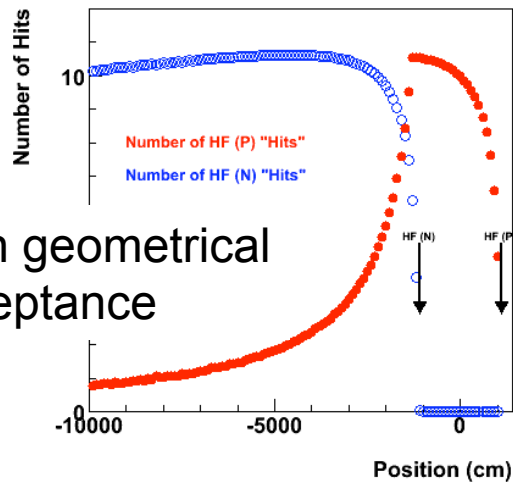

Truth with geometrical acceptance

- Hits from beam gas outside the detector volume are partially shadowed from near HF.
- Alternatively, HF has two layers
 - For real collisions (center of detector)
 - inside layer has more hits
 - For beam gas outside the detector volume
 - outside layer has more hits
- This scheme would need implemented in the HLT.



Event size - 2



- **Fold event-size vs b with Glauber b distribution**
 - Add 1MB to match pp
 - => event size distribution
 - => average event size for min-bias

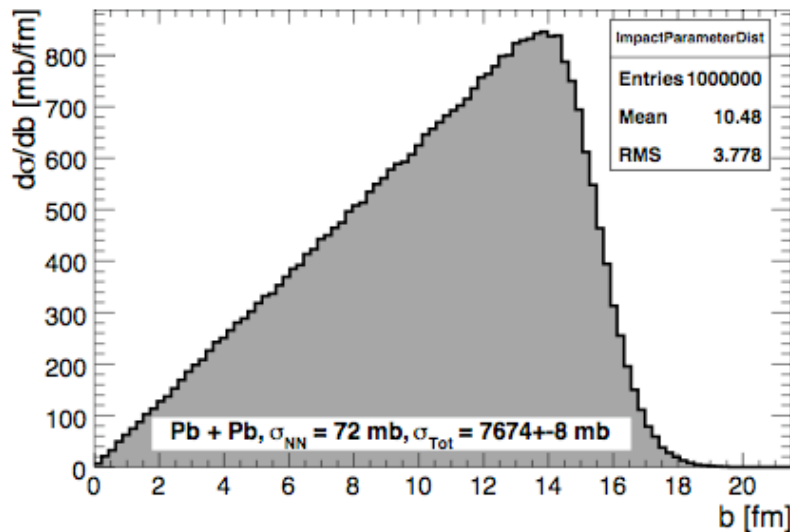
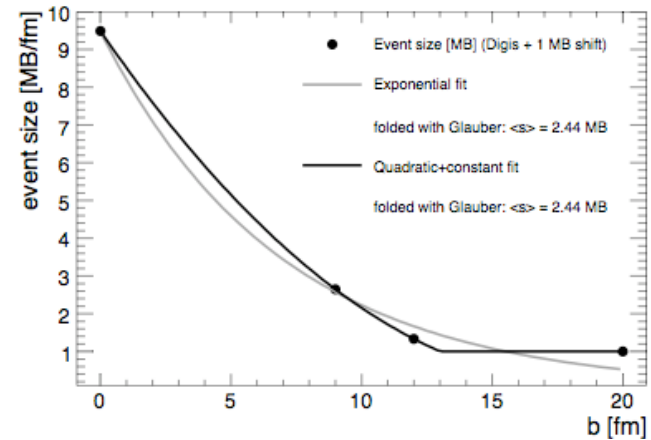

Figure 5: Impact parameter distribution calculated with a Monte Carlo Glauber simulation.

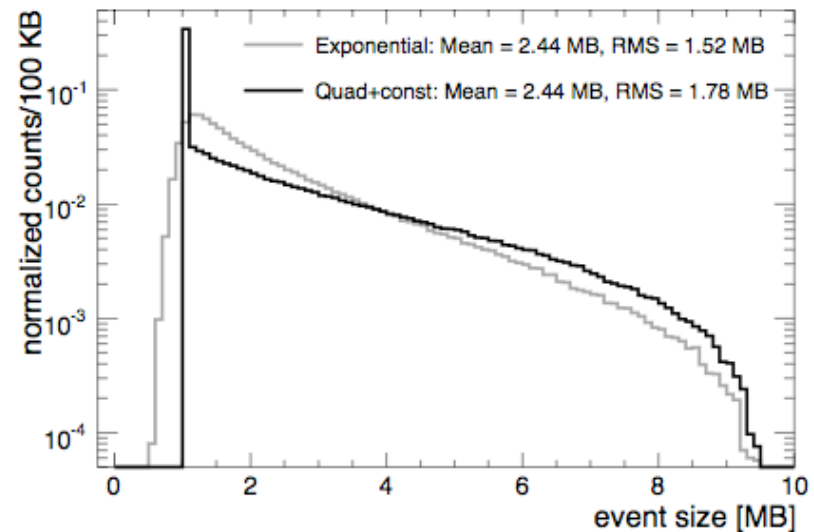

Figure 6: Minimum bias event size distributions obtained by folding two parameterizations of the event size distribution with the impact parameter distribution.



Assumptions - 4



- **Production cross-sections, charged multiplicity**
 - Cross sections from Pythia 6.236 5.5 TeV p+p
 - Implemented in HIROOT
 - Soft background/full simulations: Hydjet
 - Three samples: $dN/dy \sim 3300, 575$ and 65 for $b = 0, 9$ and 12fm
 - dN/dy for pp @ 14TeV ~ 7
 - i.e. pp total at full lumi is $dN/dy \sim 140$
 - Corresponds to $\sim 2x$ PbPb@12fm

HIROOT: ROOT with generator (Pythia etc) interface and collection of analysis classes

Glauber: Project nuclear densities of colliding nuclei to determine number of participant nucleons, number of binary collisions

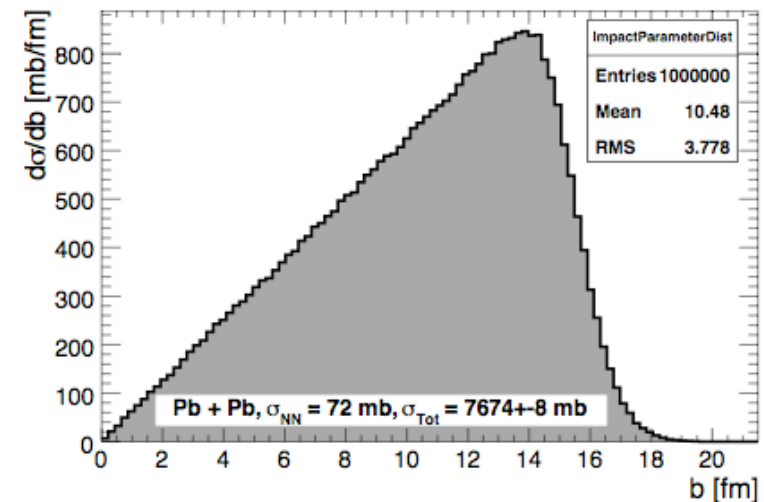

Figure 5: Impact parameter distribution calculated with a Monte Carlo Glauber simulation.