

# Reliability of a Gaussian Channel in the Presence of Gaussian Feedback

by

Aman Chawla

Submitted to the Department of Electrical Engineering and Computer Science

in partial fulfillment of the requirements for the degree of

Master of Science in Electrical Engineering and Computer Science

at the

MASSACHUSETTS INSTITUTE OF TECHNOLOGY

June 2006

© Massachusetts Institute of Technology 2006. All rights reserved.

Author .....  
Department of Electrical Engineering and Computer Science  
February 27, 2006

Certified by .....  
Sanjoy Kumar Mitter  
Professor  
Thesis Supervisor

Accepted by .....  
Arthur C. Smith  
Chairman, Department Committee on Graduate Students

# Reliability of a Gaussian Channel in the Presence of Gaussian Feedback

by

Aman Chawla

Submitted to the Department of Electrical Engineering and Computer Science  
on February 27, 2006, in partial fulfillment of the  
requirements for the degree of  
Master of Science in Electrical Engineering and Computer Science

## Abstract

The communication reliability, or error exponent, of a continuous time, infinite bandwidth, Additive White Gaussian Noise channel was studied under a peak power constraint, in the presence of a feedback channel that was also a continuous time peak-power constrained infinite bandwidth Additive White Gaussian Noise channel. Motivated by [9], a two phase scheme was studied, where, in the first phase, the Encoder transmits the message in small bit-packets and the Decoder then informs the Encoder of the decoded message. With this knowledge, in the second phase, the Encoder sends a confirm or deny signal to the Decoder and the Decoder then informs the Encoder of its final action. In the first phase, the Encoder uses an orthogonal signalling scheme and the Decoder uses a deterministic Identification code. In the second phase, the Encoder uses antipodal signalling, while the Decoder utilizes a sequential semi-orthogonal peak-power constrained anytime code. To improve the reliability of the anytime code, additional messages are pipelined into the forward channel by the Encoder once it finishes its phase two transmission, before receiving the Decoder's phase two transmission. Using this scheme, the following lower bound on the reliability of this channel is obtained:

$$E_{GaussPeak}(\bar{R}) > \left( \frac{1}{C_2} + \frac{1}{4C_1} \right)^{-1} \left( 1 - \frac{\bar{R}}{C_1} \right)$$

where  $\bar{R}$  is the average rate of data transmission and  $C_1$  and  $C_2$  are the capacities of the forward and reverse channels respectively. To achieve this reliability, the capacity of the reverse channel,  $C_2$  must be greater than the forward capacity  $C_1$ .

Thesis Supervisor: Sanjoy Kumar Mitter  
Title: Professor

## Acknowledgments

This thesis would not have been possible without the support and guidance of Prof. Sanjoy Mitter and Prof. Anant Sahai, a former student of his. Prof. Mitter has patiently waited for me, for nearly a year and a half, to find a problem of interest and then supported and encouraged my foray into it. Prof. Sahai has been very helpful, not only in formulating this problem in a precise fashion, but also providing specific directions of investigation and many useful ideas, pointers, clarifications and course-corrections.

Many lengthy discussions with fellow students Baris Nakiboglu and Lav Varshney, and post-doc Aslan Tchamkerten, and short discussions with faculty members Prof. Alan Willsky and Prof. Robert Gallager helped me clarify my concepts and understanding. The authors of all the textbooks and papers I have read are too many to thank.

Credit for this work goes in no small measure to my parents, for their many personal sacrifices for providing me a good education and thereby a secure future. Their loving and patient support and care while I prepared for countless examinations through the years is the silent and primary contributor to this affair. All the teachers I have had, starting from kindergarten right up to those here, are the hidden authors of this thesis. It is true that mine is the least contribution to this work.

Funding for this thesis was provided by the Army Research Office under the MURI Grant: Data Fusion in Large Arrays of Microsensors DAAD19-00-1-0466 and the National Science Foundation Grant CCR-0325774.

# Contents

<b>1</b>	<b>Introduction</b>	<b>6</b>
<b>2</b>	<b>Preliminaries</b>	<b>9</b>
2.1	The Sahai-Simsek Transmission Scheme . . . . .	9
2.2	The Channel Model . . . . .	10
<b>3</b>	<b>The Code and Its Analysis</b>	<b>13</b>
3.1	Phase 1 Transmission Analysis . . . . .	13
3.1.1	Encoder Phase 1 . . . . .	13
3.1.2	Decoder Phase 1 . . . . .	14
3.2	Phase 2 Transmission Analysis . . . . .	17
3.2.1	Encoder Phase 2 . . . . .	17
3.2.2	Decoder Phase 2 . . . . .	20
3.3	Total Error Probability . . . . .	23
3.4	Expected Decoding Time . . . . .	24
3.5	The Reliability Function . . . . .	24
<b>4</b>	<b>Conclusion</b>	<b>27</b>

# List of Figures

1-1	Additive Gaussian Memoryless version of communication setup in [9]. Here $Z_1 \sim \mathcal{N}(0, \frac{N_1}{2})$ and $Z_2 \sim \mathcal{N}(0, \frac{N_2}{2})$ . $Z_1 \perp Z_2$ . . . . .	8
2-1	Encoder's transmission and reception timeline under the scheme in [9], with $W = 2$ and $\frac{N}{K} = 3$ . Note that $ET_x = DR_x$ and $ER_x = DT_x$ . . .	11
3-1	The Error Exponents of Scheme 1 (Eorth) and Scheme 2 (EdID). . .	18
3-2	A sequential semi-orthogonal peak-power constrained code, based on the repeated PPM code in [7]. . . . .	22
3-3	Variable Delay Reliability Function of the Gaussian Channel with Gaus- sian Feedback . . . . .	26

# Chapter 1

## Introduction

In the field of information and communication theory, there has been much interest in the study of feedback and the role it can play in improving the reliability of information transmission. The reliability function determines the speed of decay in the error probability with block length or expected decoding time. It is nothing but the exponent of the upper bound on the probability of error of the communication scheme, divided by the expected decoding time.

We are primarily concerned with the reliability of information transmission over continuous time Additive White Gaussian Noise (AWGN) channels, in the presence of *noisy* (Gaussian) feedback (Figure 1). In the absence of any feedback whatsoever, the reliability function of this channel has been known for long [12] to be exactly given as follows

$$E(R) = \begin{cases} C/2 - R, & R \leq C/4 \\ (\sqrt{C} - \sqrt{R})^2, & C/4 \leq R \leq C \end{cases}$$

where  $C$  is the capacity of the channel and  $R$  is the rate of data transmission. This reliability is achieved by using an orthogonal signalling scheme <sup>1</sup>.

With a peak power constraint and perfect noiseless feedback for the continuous-time additive Gaussian setting, Schalkwijk and Barron [10] demonstrate a significant improvement in the achievable error exponent over a no-feedback setting, by using a

---

<sup>1</sup>However, doing list-decoding for orthogonal signaling on the  $\infty$ -bandwidth AWGN channel will extend the “curvy” part of the curve in the same manner that it extends the curvy part for DMCs [8].

two-phase sequential signalling scheme. They show that, for a peak-to-average power ratio of  $\alpha$ , the achievable error exponent is

$$E_\alpha(R) = \left( \sqrt{\alpha C - R} + \sqrt{C - R} \right)^2$$

where  $C$  is the capacity of the forward channel and  $R$  is the rate of data transmission.

The scheme of Schalkwijk and Barron was slightly modified by Yamamoto and Itoh in [13]. They avoid the use of Viterbi's sequential decision feedback scheme [11] in the second phase, but nevertheless achieve the following similar error exponent

$$E_T(R_T) = \left( \sqrt{C - R_T} + \sqrt{\alpha C - R_T} \right)^2$$

where  $R_T$  is the effective transmission rate.

In the same paper, Yamamoto and Itoh also apply their modified scheme to the case of a Discrete Memoryless Channel (DMC) with noiseless feedback and are able to achieve the Burnashev error exponent

$$E_N(R_N) = C_1 \left( 1 - \frac{R_N}{C} \right)$$

where  $C_1 = \max_{k,k'} \sum_{j=1}^J P_{jk} \ln \frac{P_{jk'}}{P_{jk}}$  and  $[P_{jk}]$  is the forward channel transition matrix.

The presence of noise in the feedback calls for some additional ideas, since it is at first glance not clear whether noisy feedback would even be useful at all. It might just increase the encoder's confusion. An approach to the analysis of the noisy feedback case is taken in [9] that looks at the situation where a stream of messages is to be conveyed to the receiver. The authors extend the above-mentioned DMC scheme of Yamamoto and Itoh [13] to the case where the feedback channel is also a DMC. Using a combination of message pipelining and anytime coding, they are able to make use of the feedback information and obtain the following lower bound on the reliability function

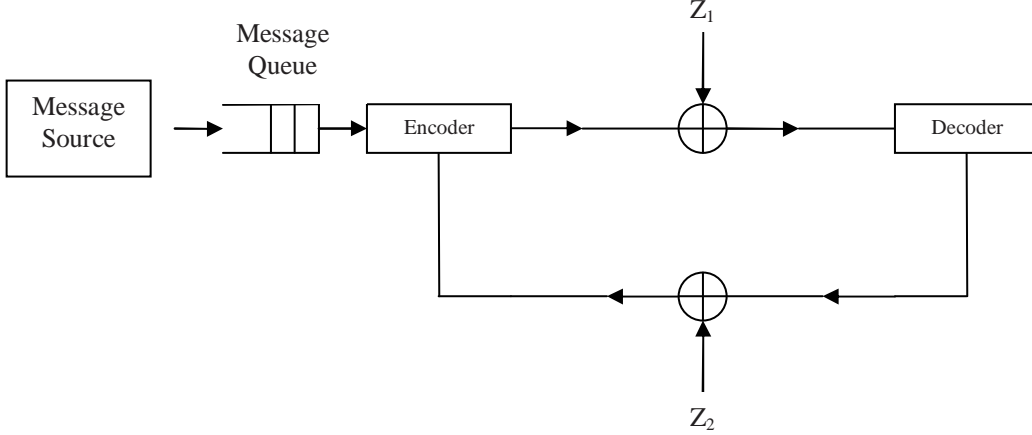

Figure 1-1: Additive Gaussian Memoryless version of communication setup in [9]. Here  $Z_1 \sim \mathcal{N}(0, \frac{N_1}{2})$  and  $Z_2 \sim \mathcal{N}(0, \frac{N_2}{2})$ .  $Z_1 \perp Z_2$ .

$$E_{noisy}(\bar{R}) \approx \left( \frac{1}{C_1} + \frac{1}{E_{ex}(R)} \right)^{-1} \left( 1 - \frac{\bar{R}}{C} \right) \quad (1.1)$$

where  $E_{ex}(R)$  is the expurgated exponent at rate  $R$ .

Since a DMC, by definition [[4], §8.5], has finite sets for its input and output alphabets, a natural next step is to see whether a similar analysis can be applied to the situation where both the forward and feedback channels are Gaussian channels with a peak power constraint. Specifically, in this thesis we will obtain the reliability function of a communication setup where both the forward and feedback channels are infinite-bandwidth continuous time peak power constrained Additive White Gaussian Noise (AWGN) channels. Figure 1-1 provides a block diagram of the setup under consideration.

The following is an outline of this thesis. In Chapter 2, we will present the preliminaries that will permit us to proceed with the detailed computation of the reliability function. In Chapter 3 we will present this computation. Finally, in Chapter 4 we will conclude with a summary of results and suggested directions for future research.



# Chapter 2

## Preliminaries

In this chapter, we will present the preliminaries that will permit us to proceed with the detailed analysis in Chapter 3. We will begin with a brief study of a variable-delay communication scheme in the context of Discrete Memoryless Channels. This scheme will be the framework in which we will study variable-delay communication in the Gaussian setting. Following this brief study, we will present the details of the point-to-point Gaussian channel that forms both the forward as well as the feedback links of the communication setup under consideration.

### 2.1 The Sahai-Simsek Transmission Scheme

In this section we will provide a brief overview of the scheme used in [9] for transmitting messages taken from a queue over a DMC, in the presence of a feedback DMC. The scheme consists of two phases. In Phase 1, a message block is transmitted and then the decoder feeds back the message block it decoded to the encoder. In Phase 2, the encoder looks at this feedback and sends the decoder a confirm/deny signal, directing it to either accept or reject that decoded message block. The encoder then waits for state information from the decoder, which tells the encoder what the decoder finally did with that message block (i.e. did it keep it or discard it). During this waiting period, the encoder continues to transmit, or pipeline, a few (say,  $W$ ) additional message blocks in the same two phase format. At the end of the waiting

period, the encoder possesses the state information and so can decide which message block to transmit next - either a retransmission of the message block or a new message from the message queue (see Figure 1-1).

Figure 2-1 provides an illustration of this scheme in action. The figure also indicates an additional feature of the scheme - before transmission, each message block is broken into sub-blocks of length  $K$  each. As each sub-block is received, it can be instantly decoded and the decoded sub-block can be immediately sent back along the feedback link. This allows a significant reduction (from  $N$  time units to  $K$  time units) in the amount of time the encoder has to wait in order to receive the entire decoded block from the decoder.

To obtain the reliability result (1.1), in Phase 1 the encoder uses a random code for transmission and the decoder uses an expurgated code. In Phase 2, the encoder uses a repetition code and the decoder uses an anytime code.

Having provided an outline of the Sahai-Simsek scheme, we can now turn to the Gaussian channel setting of Figure 1-1.

## 2.2 The Channel Model

The Gaussian channel under consideration is the infinite bandwidth continuous time Additive White Gaussian Noise channel. This channel can be specified by the following equation

$$Y(t) = X(t) + Z(t)$$

where  $X(t)$  is the input signal,  $Z(t)$  is a white noise signal having one-sided power spectral density  $N_0$  and  $Y(t)$  is the output signal. The input signal must have average power  $P$ . There is no restriction on the bandwidth used by the input signal.

To use this channel for communication, we must specify the signalling scheme. The signal set consists of  $M$  signals of duration  $T$  each:  $\{s_1(t), \dots, s_M(t)\}$ . The signals satisfy

$$\int_0^T s_i^2(t) dt = PT$$

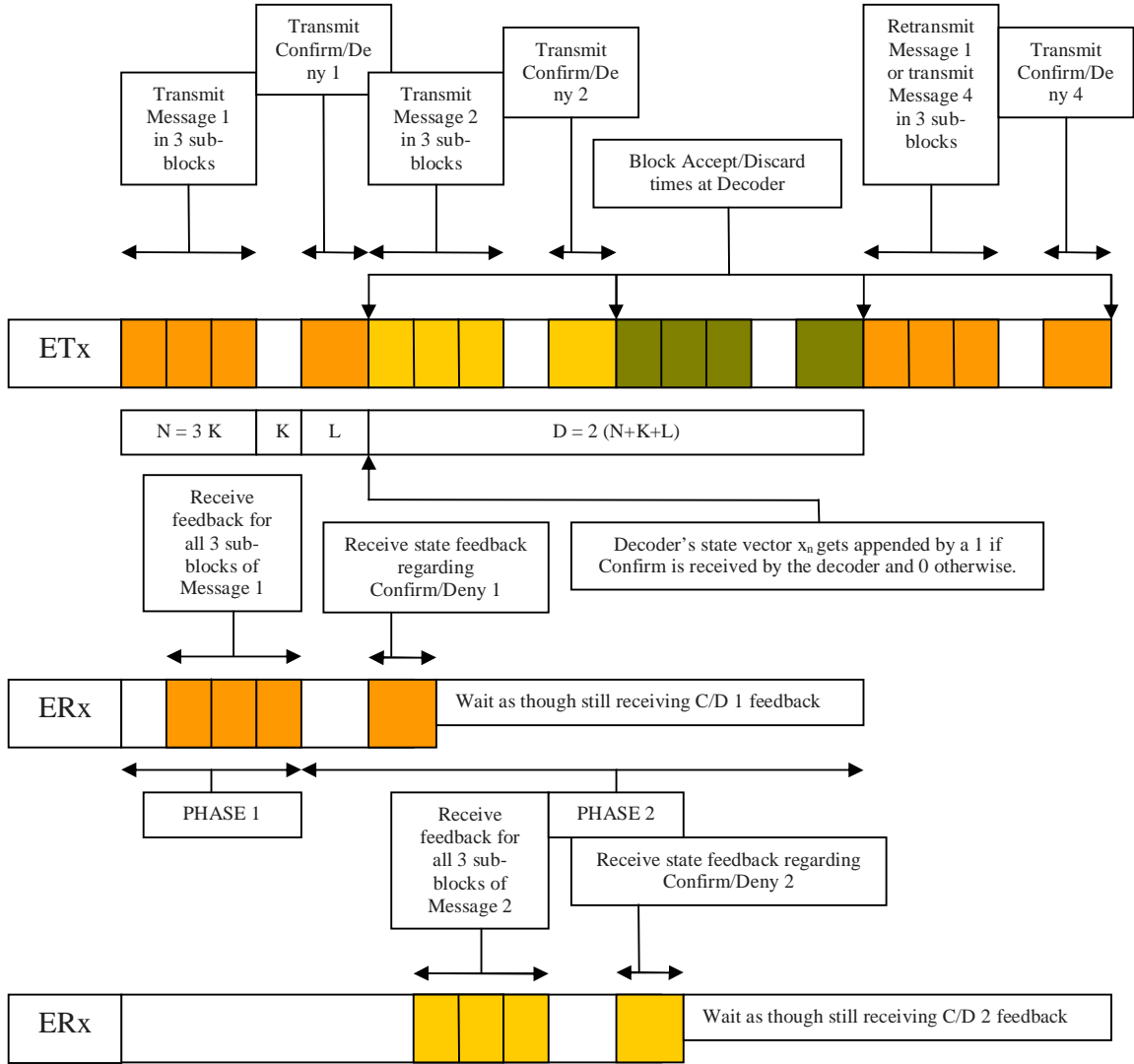

Figure 2-1: Encoder's transmission and reception timeline under the scheme in [9], with  $W = 2$  and  $\frac{N}{K} = 3$ . Note that  $ETx = DRx$  and  $ERx = DTx$ .

in order to meet the average power constraint. Thus, by transmitting one of these  $M$  signals, one communicates  $\log_2(M)$  bits of information to the receiver. The rate  $R$  of data transmission is thus  $\frac{\log_2(M)}{T}$  bits per second. The maximum such rate at which data can be transmitted with an arbitrarily small probability of error, i.e. the capacity of this channel is  $C = \frac{P}{N_0}$ .

For this channel, [12] shows that the reliability function is given exactly as

$$E(R) = \begin{cases} C/2 - R, & R \leq C/4 \\ (\sqrt{C} - \sqrt{R})^2, & C/4 \leq R \leq C \end{cases} \quad (2.1)$$

and this reliability is achieved by an orthogonal signal set, i.e.

$$\int_0^T s_i(t)s_j(t)dt = PT\delta_{ij}$$

for  $i, j \in \{1, \dots, M\}$ . These orthogonal signals can be designed such that their peak power is the same as their average power. This is the tightest possible peak power constraint (since the ratio of peak to average power is 1).

This completes our description of the channel. In the remainder of the thesis, the forward channel will have capacity  $C_1 = \frac{P_1}{N_1}$  and the feedback channel will have capacity  $C_2 = \frac{P_2}{N_2}$ .

# Chapter 3

## The Code and Its Analysis

In this chapter we will present the details of the transmission scheme, and undertake a computation of the variable-delay reliability function.

A message source produces one among  $M$  equiprobable outcomes at regular intervals of time. Each  $M$ -ary message enters into a message queue as illustrated in Figure 1-1. It is the job of the Encoder to transmit these messages to the Decoder over the channel in a reliable fashion.

### 3.1 Phase 1 Transmission Analysis

The transmission cycle begins with transmissions originating at the Encoder, over the forward channel. We will first look at the Encoder's phase 1 transmission.

#### 3.1.1 Encoder Phase 1

The message  $m$ , representing  $\log_2(M)$  bits of information arrives at the Encoder from the queue. This message is broken into  $K$  packets, each containing  $\frac{\log_2(M)}{K}$  bits of information. The Encoder transmits one packet at a time using the orthogonal signalling scheme discussed in section 3. Clearly, the number of messages required in the signal set for transmitting a packet is  $M^{\frac{1}{K}}$ . Each continuous time signal in the signal set is of duration  $\frac{T_1}{K}$  seconds, and has peak power the same as the average

power  $P_1$ . The rate of data transmission is

$$\begin{aligned} R &= \frac{\log_2(M) K}{K T_1} \\ &= \frac{\log_2(M)}{T_1} \text{ bits per second.} \end{aligned} \tag{3.1}$$

As each packet arrives at the Decoder, it performs Maximum Likelihood (ML) decoding on that packet. From [[6], §8.2], this yields the following probability of error.

$$P_e^{(1)} \triangleq \Pr(\text{packet is incorrectly decoded}) = f\left(R, \frac{T_1}{K}\right) e^{-\frac{T_1}{K} E_{orth}(R)} \tag{3.2}$$

where  $E_{orth}(R)$  is given by (2.1) by replacing  $C$  with  $C_1$ .

In  $K$  such transmissions, requiring total time  $T_1$ , the entire message  $m$  is transmitted by the Encoder. Assuming, for simplicity, that the transmissions started at time 0, at time  $T_1$  the Decoder has thus received and decoded a total of  $\log_2(M)$  bits. Using the Union bound,

$$\begin{aligned} P_e^{(2)} &\triangleq \Pr(\text{overall decoded message } m' \neq m) \\ &= \bigcup_{i=1}^K \Pr(\text{packet } i \text{ decoded incorrectly}) \\ &\leq \sum_{i=1}^K \Pr(\text{packet } i \text{ decoded incorrectly}) \\ &= \sum_{i=1}^K P_e^{(1)} \\ &= K P_e^{(1)} \end{aligned} \tag{3.3}$$

### 3.1.2 Decoder Phase 1

As each packet arrives at the Decoder, it decodes it immediately (using ML decoding as discussed above in §4.1.1). Let us suppose that ML decoding yields message  $m' = p$  where  $p \in \{1, \dots, M^{\frac{1}{K}}\}$ . Denote the actual message sent by the Encoder as  $m = l$ .

For the Encoder to be able to proceed with Phase 2, it needs to know whether or not  $p = l$ . We can consider two alternative schemes for communicating this information from the Decoder to the Encoder.

In the first scheme, the Decoder transmits the decoded packet back to the Encoder using essentially the same orthogonal signalling scheme that we discussed in the previous section. The signal set consists of  $M^{\frac{1}{K}}$  orthogonal continuous time signals, each of duration  $\frac{T_3}{K}$ , with peak power the same as their average power  $P_2$ . The rate of data transmission is  $R = \frac{\log_2(M)}{T_3}$  bits per second.

As each such packet arrives at the Encoder, it performs ML decoding. This yields the following probability of error.

$$P_e^{(3)} \triangleq \Pr(\text{packet is incorrectly decoded}) = f\left(R, \frac{T_3}{K}\right) e^{-\frac{T_3}{K} E_{orth}(R)} \quad (3.4)$$

where  $E_{orth}(R)$  is given by (2.1) by replacing  $C$  with  $C_2$ .

The probability that the Encoder thinks the Decoder received the correct message, i.e.  $m'' = m$  when in fact it didn't, i.e.  $m' \neq m$  is upper bounded by the probability that an error is made by the Encoder in decoding the feedback sent by the Decoder.

$$\begin{aligned} P_e^{(4)} &\triangleq \Pr(m'' = m \neq m') && (3.5) \\ &\leq \Pr(m'' \neq m') \\ &= \bigcup_{i=1}^K \Pr(\text{packet } i \text{ decoded incorrectly}) \\ &\leq \sum_{i=1}^K \Pr(\text{packet } i \text{ decoded incorrectly}) \\ &= \sum_{i=1}^K P_e^{(3)} \\ &= K P_e^{(3)} \end{aligned}$$

where the second inequality follows from the Union Bound. The first inequality can be tightened with further analysis.

In the second scheme, we exploit the fact that all the Encoder is interested in, is whether or not  $m' = l$ . Beyond this, it is not interested in knowing exactly what the value of  $m'$  is. Thus we have here a standard Identification (ID) problem, which was first introduced in [1] for Discrete Memoryless Channels. In [3] Burnashev considers the case of the infinite bandwidth Additive White Gaussian Noise Channel. Using essentially the same orthogonal signalling scheme that we discussed in the previous section, he constructs a deterministic ID (dID) code and computes the probabilities of missed detection and false alarm. The signal set consists of  $M$  orthogonal continuous time signals  $S_i(t)$ , each of duration  $\frac{T_3}{K}$ , with peak power the same as their average power  $P_2$ . The rate of the dID code is  $R_{dID} = \frac{K \ln \ln M}{T_3}$  [3].

Having received and decoded all the  $K$  packets from the Encoder, the Decoder transmits signal  $S_j(t)$  if the overall decoded message received by it is  $j$  where  $j \in \{1, \dots, M\}$ . We fix a real number  $z > 0$  and define the decision region  $D_l(z)$  as follows:

$$D_l(z) \triangleq \left\{ Y(t) : \int_0^{\frac{T_3}{K}} Y(t) S_l(t) dt \geq z \right\}$$

If the received signal  $Y(t)$  falls in the decision region  $D_l(z)$ , where  $l$  is the message the Encoder wishes to identify, then the Encoder prepares to send a Confirm in Phase 2. If the received signal does not fall in the decision region  $D_l(z)$ , then the Encoder prepares to send a Deny in Phase 2. The probability of a False Alarm, i.e., the received signal falls in  $D_l(z)$  when the Decoder actually sent  $S_j(t)$ ,  $j \neq l$ , is calculated to be

$$P_{fa}^{(1)} \triangleq \Pr(Y(t) \in D_l(z) | S_j(t) \text{ sent}, j \neq l) = \Phi \left( \frac{-z}{\sqrt{\frac{N_2 P_2 T_3}{2K}}} \right) \quad (3.6)$$

The probability of a Missed Detection, i.e., the received signal falls in  $D_j(z)$ ,  $j \neq l$  when the Decoder actually sent  $S_l(t)$ , is calculated to be

$$P_{md}^{(1)} \triangleq \Pr(Y(t) \in D_j(z), j \neq l | S_l(t) \text{ sent}) = \Phi \left( \frac{z - P_2 \left( \frac{T_3}{K} \right)}{\sqrt{\frac{N_2 P_2 T_3}{2K}}} \right) \quad (3.7)$$



In this second scheme,  $P_{fa}^{(1)}$  plays the role of  $\Pr(m'' = m \neq m')$ . We therefore wish to make it as small as possible. However, we have a constraint that the probability of missed detection,  $P_{md}^{(1)}$  be less than  $10^{-5}$ . Setting  $P_{md}^{(1)} = 10^{-5}$ , and using (3.7) we can compute  $z = P_2 \frac{T_3}{K} - 4\sqrt{\frac{P_2 N_2 T_3}{2K}}$  and thereby, from (3.6), and using  $\Phi(x) \leq e^{-\frac{x^2}{2}}$ , we obtain

$$P_{fa}^{(1)} \leq e^{-8} e^{-(C_2 \frac{T_3}{K} + 4\sqrt{\frac{2P_2 T_3}{N_2 K}})} \quad (3.8)$$

which, on dropping sublinear terms, yields the exponent

$$E_{dID} = C_2 \quad (3.9)$$

independent of the size of the message set  $M$ , and hence independent of the rate of the dID code. By comparison, from (3.4) and (3.5), the reliability function of the first scheme is  $E_{orth}(R)$ , given by (2.1) by replacing  $C$  with  $C_2$ . The two reliability functions are illustrated in Figure 3-1.

It is clear from Figure 3-1 that regardless of the rate, the second scheme is to be preferred over the first. Note that the second scheme also saves the Decoder much transmission energy on the feedback - it need transmit only once where it would have done so  $K$  times in the first scheme.

## 3.2 Phase 2 Transmission Analysis

We can now analyse the second phase of transmission. We will first look at the Encoder transmission, which begins at time  $T_1 + \frac{T_3}{K}$ .

### 3.2.1 Encoder Phase 2

Using its decision regarding whether or not the Decoder obtained the right message in Phase 1, the Encoder does the following. In case the right message was received, the Encoder sends a Confirm signal which indicates to the Decoder that it ought to keep the just-decoded block. Otherwise, the Encoder sends a Deny signal which indicates

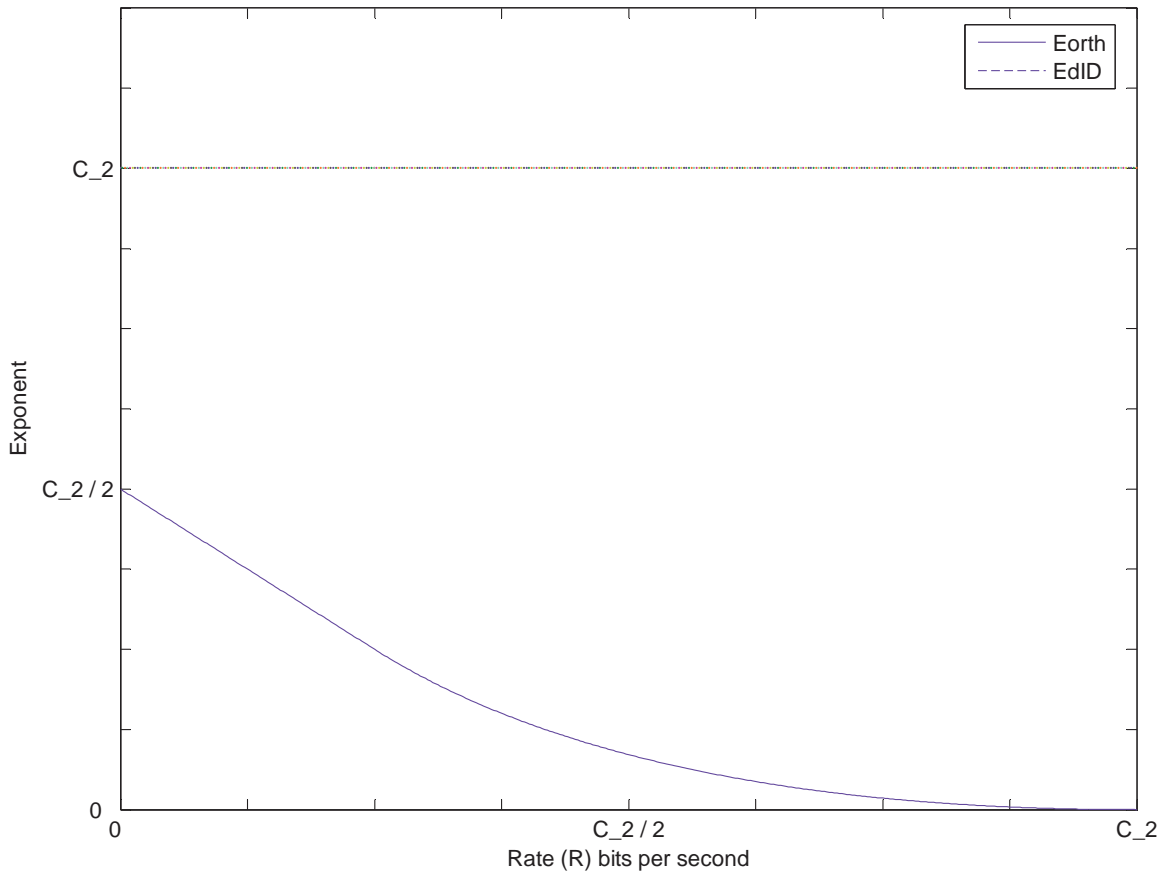

Figure 3-1: The Error Exponents of Scheme 1 (Eorth) and Scheme 2 (EdID).

to the Decoder that it ought to discard the just-decoded block. The Encoder uses a pair of antipodal signals  $\{r(t), -r(t)\}$ , the former to indicate a confirm and the latter a deny. Each signal is of duration  $T_2$ , with peak power the same as the average power  $P_1$ .

Let the received signal be  $Y(t)$ . We fix a real number  $z > 0$  and decode to a Confirm if

$$\int_0^{T_2} Y(t)r(t)dt \geq z \quad (3.10)$$

and to a Deny if

$$\int_0^{T_2} Y(t)r(t)dt < z. \quad (3.11)$$

We then compute the probabilities of Missed Detection and False Alarm as follows.

$$\begin{aligned} P_{md}^{(2)} &= \Pr(\text{Decode to Deny} \mid \text{Confirm sent}) \quad (3.12) \\ &= \Pr\left(\int_0^{T_2} Y(t)r(t)dt < z \mid r(t) \text{ sent}\right) \\ &= \Pr\left(\int_0^{T_2} Z(t)dt < \frac{z - P_1 T_2}{\sqrt{P_1}}\right) \\ &= \Phi\left(\frac{z - P_1 T_2}{\sqrt{\frac{P_1 N_1 T_2}{2}}}\right) \end{aligned}$$

$$\begin{aligned} P_{fa}^{(2)} &= \Pr(\text{Decode to Confirm} \mid \text{Deny sent}) \quad (3.13) \\ &= \Pr\left(\int_0^{T_2} Y(t)r(t)dt \geq z \mid -r(t) \text{ sent}\right) \\ &= \Pr\left(-\int_0^{T_2} Z(t)dt \leq \frac{-(z + P_1 T_2)}{\sqrt{P_1}}\right) \\ &= \Phi\left(\frac{-(z + P_1 T_2)}{\sqrt{\frac{P_1 N_1 T_2}{2}}}\right) \end{aligned}$$

If we set  $z = 0$ , we obtain  $P_{fa}^{(2)} \leq e^{-C_1 T_2}$ . Thus the exponent is  $C_1$ , independent

of the rate. On the other hand, we can fix the probability of missed detection to be some value, say  $10^{-5}$ , and then determine the value of  $z$  as follows

$$\begin{aligned}
P_{md}^{(2)} &= \Phi\left(\frac{z - P_1 T_2}{\sqrt{\frac{P_1 N_1 T_2}{2}}}\right) \\
&= 10^{-5} \\
\Rightarrow \frac{z - P_1 T_2}{\sqrt{\frac{P_1 N_1 T_2}{2}}} &= -4 \\
\Rightarrow z &= P_1 T_2 - 4\sqrt{\frac{P_1 N_1 T_2}{2}}
\end{aligned} \tag{3.14}$$

Thus, from (3.13), we obtain

$$P_{fa}^{(2)} \leq e^{-8} e^{-(4C_1 T_2 - 8\sqrt{2}\sqrt{C_1 T_2})} \tag{3.15}$$

which, on dropping sublinear terms, yields the exponent  $4C_1 T_2$ .

### 3.2.2 Decoder Phase 2

Once the Decoder has decoded the phase 2 encoder signal, it performs the corresponding operation, i.e. it either discards or accepts the just-decoded block. What action it performs constitutes 1 bit of information about its state. This information must be conveyed back to the Encoder. Using this information the Encoder will decide which message to transmit next. Thus it is quite important for the Decoder to communicate the state information bit sequence in a reliable fashion.

We can do so by using an anytime code for this purpose. In [7], the author presents a sequential semi-orthogonal anytime code for the infinite bandwidth AWGN channel. It is a repeated pulse position modulation (PPM) scheme. However, the analysis in [7] is not unique to PPM. The same analysis goes through even with a signal set that meets the constraint that the peak power be the same as the average power  $P_2$ . Specifically, the signal set consists of square waves  $g_i(t)$ , each of duration  $T_4$

seconds, arranged on a tree-structure (growing from left to right), with  $i$  being an index to the branch of the tree that the signal  $g_i(t)$  occupies. The index can be, for example, a simple binary sequence that allows one to navigate to that signal, with 0 being appended when you move “up”, and 1 when you move “down”. If we consider all the signals at any particular “level” of the tree, the number of their zero crossings increases by powers of 2 as one goes down that level. The amplitude of each square wave is of course  $\sqrt{P_2}$ . This tree structure, illustrated in Figure 3-2, gives the code the important characteristic that every  $T_4$  seconds, not only is an additional bit communicated, but also all previous bits are repeated.

At time  $T_1 + \frac{T_3}{K} + T_2 + T_4$  the Encoder receives the first state information signal, say,  $g_0(t)$ . It doesn’t immediately decode this signal. Instead, in order to increase the reliability of the decoding, the Encoder operates at a fixed delay  $W$ , i.e. it waits for a sequence of  $W$  signals to arrive before it decodes the first bit from the sequence. As shown in [7], this allows the Encoder to operate with an error probability given by

$$\begin{aligned}
 P_e^{(5)} &\triangleq \Pr(\text{Received Decoder state information,} & (3.16) \\
 &\quad \text{from bit 1 upto the bit received via the signal} \\
 &\quad \text{that arrived W signals ago, is incorrect)} \\
 &\leq K' e^{-W E_{orth}(R'') T_4}
 \end{aligned}$$

where  $R'' = \frac{1}{T_4}$  bits per second is the rate of the anytime code,  $K' > 0$  is a constant, and  $E_{orth}(R)$  is given by (2.1) by replacing  $C$  with  $C_2$ . Equation (3.16) thus gives the probability that the Encoder selects the wrong message to transmit. Note that during the delay period  $D = W(T_1 + \frac{T_3}{K} + T_2)$  the Encoder transmits an additional  $W$  messages from the message queue.

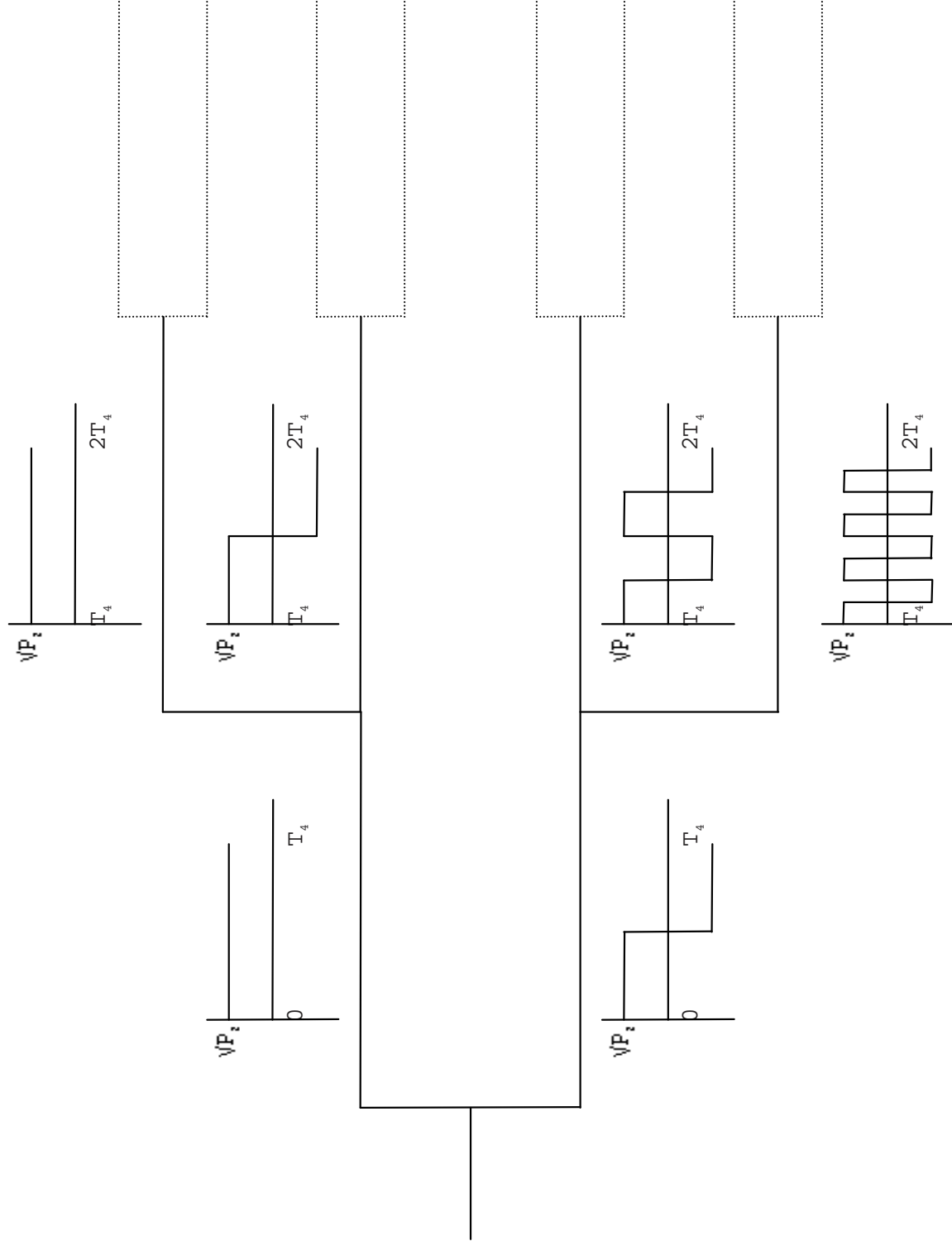

Figure 3-2: A sequential semi-orthogonal peak-power constrained code, based on the repeated PPM code in [7].

### 3.3 Total Error Probability

Having obtained the error probabilities of the individual phases of the scheme, we are now in a position to compute the total probability of unrecoverable errors of the scheme. An overall uncorrectable error occurs if one of the following occur [9].

1. The Encoder sends a Deny but it is decoded as a Confirm. This occurs with an exponent  $4C_1T_2$ , from (3.15).
2. The Encoder sends a Confirm when it ought to have sent a Deny. This occurs with an exponent  $C_2\frac{T_3}{K}$ , from (3.8).
3. The Encoder selects the wrong message to transmit. This occurs with an exponent  $WE_{orth}(R'')T_4$ , from (3.16).

We can choose parameters such that all the above exponents are identical. Equating the first two exponents, we obtain

$$K = \frac{C_2T_3}{4C_1T_2} \quad (3.17)$$

Since  $K$  is the number of bit packets that each message is broken into, we must have  $K > 1$ . This yields the requirement that

$$C_2 > \frac{C_14T_2}{T_3}. \quad (3.18)$$

Equating the first and third exponents, we obtain

$$W = \frac{4C_1T_2}{E_{orth}(R'')T_4} \quad (3.19)$$

which is always non-negative, since  $E_{orth}(\frac{1}{T_4})$  is non-negative.

Thus, the total (uncorrectable) error probability has the exponent

$$-\ln P_e = 4C_1T_2 + \text{sublinear terms}. \quad (3.20)$$

### 3.4 Expected Decoding Time

We wish to obtain the expected time that it takes for a message to be sent from the Encoder to the Decoder. Let us consider the cases in which a retransmission of a message is required [9].

1. Any packet of the Phase 1 Encoder transmission is received incorrectly. This has probability given by (3.3). This probability can be made arbitrarily small by increasing  $T_1$ .
2. A Confirm sent by the Encoder is decoded as a Deny. This is a constant,  $10^{-5}$ , given by (3.14).

Thus the probability that a message will be retransmitted is  $\leq P_e^{(2)} + 10^{-5}$ . Thus a transmitted message is accepted with probability  $\geq 1 - P_e^{(2)} - 10^{-5}$ . The possible message acceptance times are  $\{(T_1 + \frac{T_3}{K} + T_2), (W + 1)(T_1 + \frac{T_3}{K} + T_2), 2(W + 1)(T_1 + \frac{T_3}{K} + T_2), \dots\}$ . Thus, the expected duration for a message to be successfully transmitted,  $\bar{\tau}$ , is upper bounded by

$$\begin{aligned} & (T_1 + \frac{T_3}{K} + T_2) \left( 1 + \frac{P_e^{(2)} + 10^{-5}}{1 - P_e^{(2)} - 10^{-5}} (W + 1) \right) & (3.21) \\ & \cong (T_1 + \frac{T_3}{K} + T_2) \\ & = T_1 + T_2 \left( 1 + \frac{4C_1}{C_2} \right) \end{aligned}$$

where the second line holds because  $10^{-5}$  is negligible and  $P_e^{(2)}$  can be made arbitrarily small. The third line follows from (3.17).

### 3.5 The Reliability Function

We are now in a position to derive a lower bound on the reliability function  $E_{GaussPeak}(\bar{R})$  of the transmission scheme. Here  $\bar{R} = \frac{\log_2(M)}{\bar{\tau}}$  is the average number of bits per second transmitted by the scheme.



Using (3.1) and (3.20), (3.21) becomes

$$\bar{\tau} < \frac{\log_2(M)}{R} - \frac{\ln P_e}{4C_1} \left(1 + 4\frac{C_1}{C_2}\right) \quad (3.22)$$

where  $R$  is the nominal rate of data transmission by the Encoder in Phase 1.

Thus,

$$\begin{aligned} 1 &< \frac{\log_2(M)}{\bar{\tau}R} + \frac{-\ln P_e}{\bar{\tau}4C_1} \left(1 + 4\frac{C_1}{C_2}\right) \\ &= \frac{\bar{R}}{R} + E_{GaussPeak}(\bar{R}) \left(\frac{1}{C_2} + \frac{1}{4C_1}\right) \end{aligned} \quad (3.23)$$

Thus,

$$E_{GaussPeak}(\bar{R}) > \left(\frac{1}{C_2} + \frac{1}{4C_1}\right)^{-1} \left(1 - \frac{\bar{R}}{R}\right) \quad (3.24)$$

In order to maximize the lower bound, we must maximize  $R$ . Thus the optimal value of  $T_1$  is  $\frac{\log_2(M)}{C_1}$  seconds. Thus, the lower bound now becomes

$$E_{GaussPeak}(\bar{R}) > \left(\frac{1}{C_2} + \frac{1}{4C_1}\right)^{-1} \left(1 - \frac{\bar{R}}{C_1}\right) \quad (3.25)$$

This lower bound is plotted in Figure 3-3.

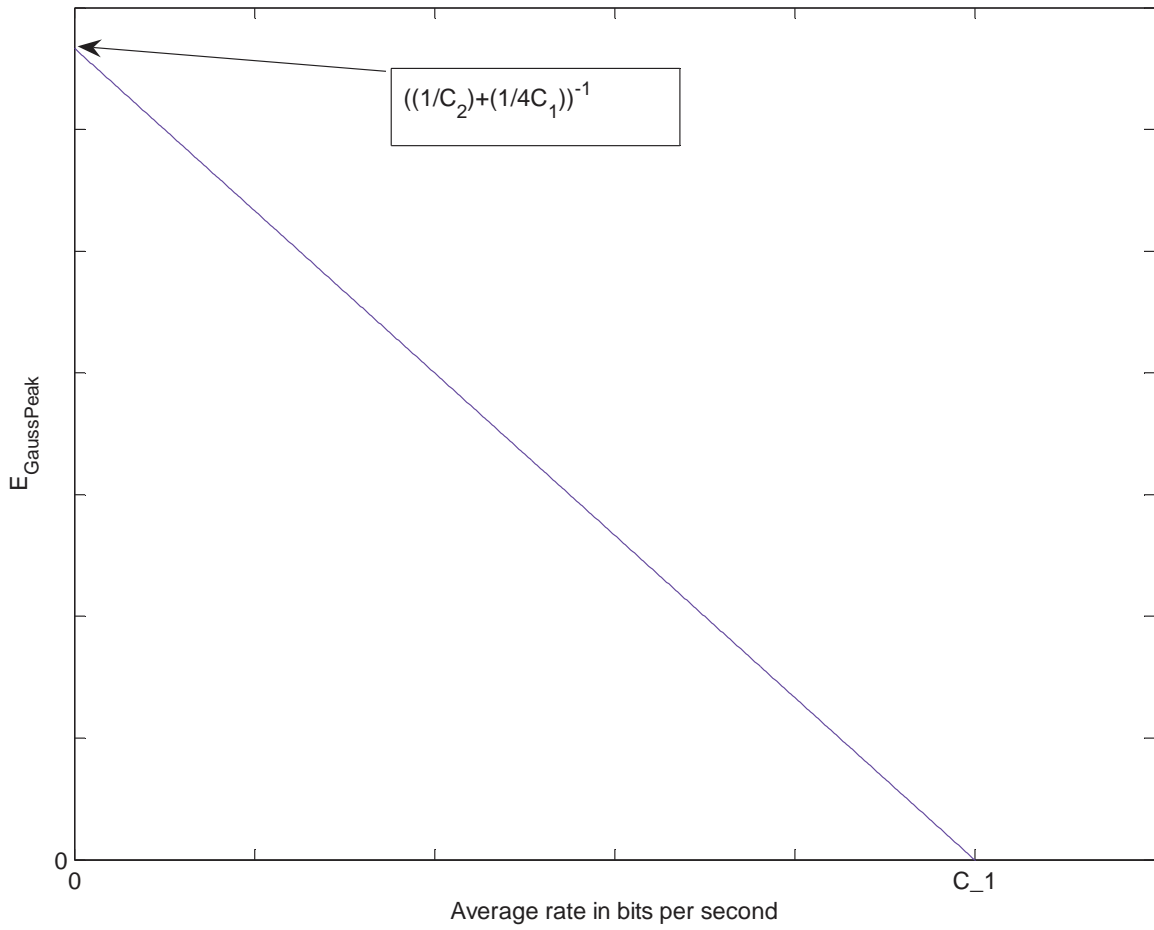

Figure 3-3: Variable Delay Reliability Function of the Gaussian Channel with Gaussian Feedback

# Chapter 4

## Conclusion

In this thesis, we computed the variable-delay reliability function of an infinite-bandwidth peak power constrained continuous time Additive White Gaussian Noise channel in the presence of a similar feedback channel. The main ingredients of the communication scheme used were, an orthogonal signalling scheme to transmit the message, a deterministic Identification code to obtain feedback, antipodal signalling to confirm or deny the last message, and finally, a sequential code to transmit decoder state information back to the encoder. In combination with message pipelining, this scheme yielded a lower bound on the reliability function

$$E_{GaussPeak}(\bar{R}) > \left( \frac{1}{C_2} + \frac{1}{4C_1} \right)^{-1} \left( 1 - \frac{\bar{R}}{C_1} \right)$$

This reliability was achievable under the condition that the capacity of the feedback channel be greater than that of the forward channel [cf. (3.18)].

Our approach to this problem was motivated by the scheme of Sahai and Simsek [9] which considered an identical situation, but for Discrete Memoryless Channels. They computed the reliability for variable-delay decoding on DMCs with noisy feedback and were able to show that as the quality of the feedback link improves, i.e. as the feedback gets less noisy, the reliability function approaches the Burnashev exponent. The Burnashev exponent is the highest possible variable delay error exponent achievable when a DMC is used with noiseless feedback [2]. In a recent paper [5], as

yet unpublished, the authors look at a similar forward and feedback DMC scenario, where the rate of communication on the forward link is greater than the capacity of the feedback link. They work with a slight modification of the scheme in [9]. Instead of the Decoder transmitting the decoded message back to the Encoder using an expurgated code, or utilizing an Identification code as in this thesis, the Decoder transmits a random hash of the decision that it makes. A hash is simply a “blurred” version of the decision - several message values are mapped to a single bin. Thus, for example, if  $m' = 9$ , a random partition of the set  $\{1, 2, \dots, M\}$  is made and the index of the partition in which 9 falls is sent to the Encoder. Using this modified scheme, the authors are able to obtain an exponent that, at average rates close to capacity, is equal to half the Burnashev exponent.

A possible direction of future research is therefore to investigate whether utilizing a similar random hashing strategy in place of the Decoder Phase 1 strategies studied in Chapter 3 would make a difference in the reliability function that can be achieved in the Gaussian setting considered in this thesis.

# Bibliography

- [1] R. Ahlswede and G. Dueck. Identification via channels. *IEEE Tran. Inf. Theory*, IT-35(1), January 1989.
- [2] M. V. Burnashev. Data transmission over a discrete channel with feedback. Random transmission time. *Translated from Problemy Peredachi Informatsii*, 12(4):10–30, October 1976.
- [3] M. V. Burnashev. On identification capacity of infinite alphabets or continuous-time channels. *IEEE Tran. Inf. Theory*, IT-46(7), November 2000.
- [4] T. M. Cover and J. A. Thomas. *Elements of Information Theory*. John Wiley and Sons, New York, NY, USA, 1991.
- [5] Stark C. Draper and Anant Sahai. Noisy feedback improves communication reliability. *Submitted to IEEE Symposium on Information Theory*, 2006.
- [6] Robert Gallager. *Information Theory and Reliable Communication*. John Wiley and Sons, New York, NY, USA, 1968.
- [7] Anant Sahai. Anytime coding on the infinite bandwidth AWGN channel: A sequential semi-orthogonal code. *Conference on Information Sciences and Systems, The John Hopkins University*, March 2005.
- [8] Anant Sahai. Forthcoming MS Thesis of student Paul Liu. *Personal communication*, February 2006.

- [9] Anant Sahai and Tunc Simsek. On the variable-delay reliability function of discrete memoryless channels with access to noisy feedback. *ITW2004, San Antonio, Texas*, October 2004.
- [10] J. P. M. Schalkwijk and M. E. Barron. Sequential signaling under a peak power constraint. *IEEE Tran. Inf. Theory*, IT-17(3), May 1971.
- [11] A. J. Viterbi. The effect of sequential decision feedback on communication over the gaussian channel. *Inform. Contr.*, 8(1):80–92, February 1965.
- [12] A. D. Wyner. On the probability of error for communication in white gaussian noise. *IEEE Tran. Inf. Theory*, IT-13(1), January 1967.
- [13] H. Yamamoto and K. Itoh. Asymptotic performance of a modified Schalkwijk-Barron scheme for channels with noiseless feedback. *IEEE Tran. Inf. Theory*, IT-25(6), November 1979.