



US006388629B1

(12) **United States Patent**  
**Albats, Jr. et al.**

(10) **Patent No.:** **US 6,388,629 B1**  
(45) **Date of Patent:** **May 14, 2002**

- (54) **ROTATING SCANNING ANTENNA APPARATUS AND METHOD FOR LOCATING BURIED OBJECTS**
- (75) Inventors: **Paul Albats, Jr.**, Ridgefield; **Macyln Burns**, Danbury; **Mark Dalton**, Brookfield; **Anthony DeRubeis**, Danbury; **Cliff Evans**, Newtown; **Jakob Haldorsen**, Norwalk, all of CT (US); **Thorkild Hansen**, Brighton, MA (US); **Douglas E. Miller**, Sandy Hook; **Michael L. Oristaglio**, Newtown, both of CT (US)
- (73) Assignee: **Witten Technologies, Inc.**, Washington, DC (US)
- (\* ) Notice: Subject to any disclaimer, the term of this patent is extended or adjusted under 35 U.S.C. 154(b) by 0 days.
- (21) Appl. No.: **09/703,570**
- (22) Filed: **Nov. 1, 2000**
- (51) **Int. Cl.<sup>7</sup>** ..... **H01Q 3/00; G01S 13/04**
- (52) **U.S. Cl.** ..... **343/757; 342/22; 342/158**
- (58) **Field of Search** ..... **343/757, 758, 343/759, 763, 765, 766, 880, 882; 342/22, 158; 73/78; 175/26; H01Q 3/00; G01S 13/04**

- (56) **References Cited**
- U.S. PATENT DOCUMENTS**
- 4,967,199 A 10/1990 Gunton et al. .... 342/22
- 5,952,561 A \* 9/1999 Jaselskis et al. .... 73/78
- 6,161,630 A \* 12/2000 Stump et al. .... 175/26
- OTHER PUBLICATIONS**
- D.J. Daniels; *Surface-Penetrating Radar*; The Institute of Electrical Engineers 1996; p.200-204.
- \* cited by examiner
- Primary Examiner*—Hoanganh Le
- (74) *Attorney, Agent, or Firm*—Fulbright & Jaworski LLP

(57) **ABSTRACT**

A ground penetrating antenna apparatus and method are provided for locating underground objects via radar, sonar, or similar methods. The apparatus includes one or more antennas that are rotatably affixed to support extensions that also rotate, but about an axis that is different from each of the antenna axes. The apparatus includes a linear propulsion mechanism, and the support extensions may be coupled to the linear propulsion mechanism via a transmission mechanism. In one embodiment, the supporting extensions rotate at a constant rate and each antenna rotates at that same constant rate but in the opposite direction.

**20 Claims, 6 Drawing Sheets**

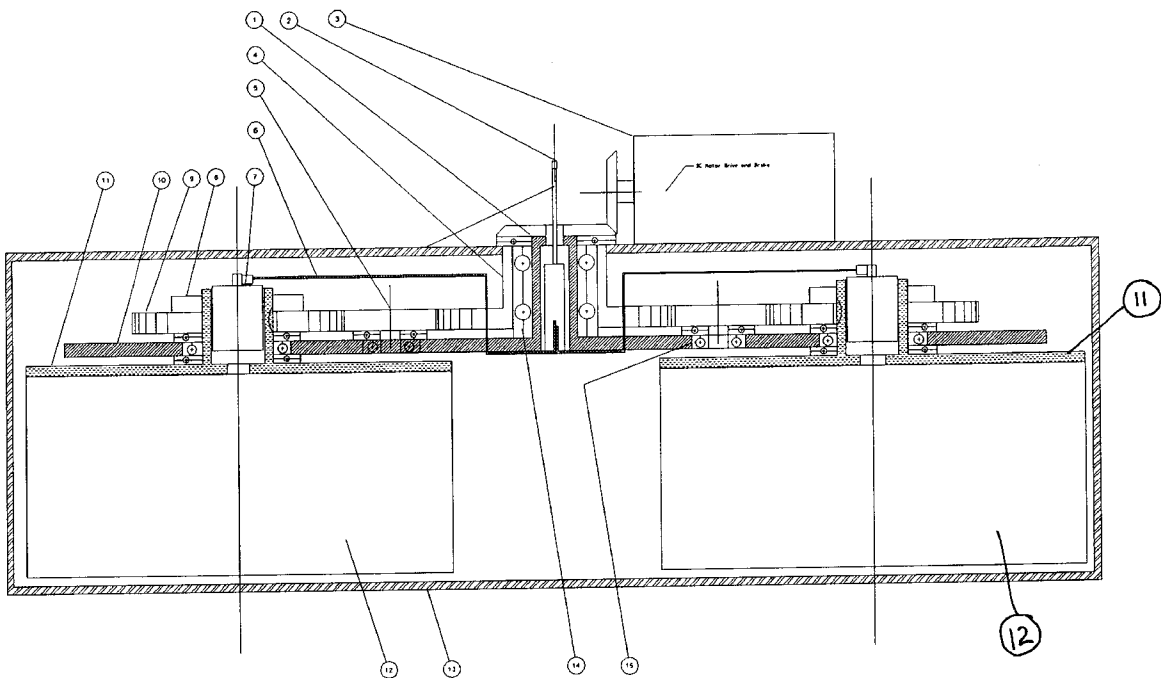

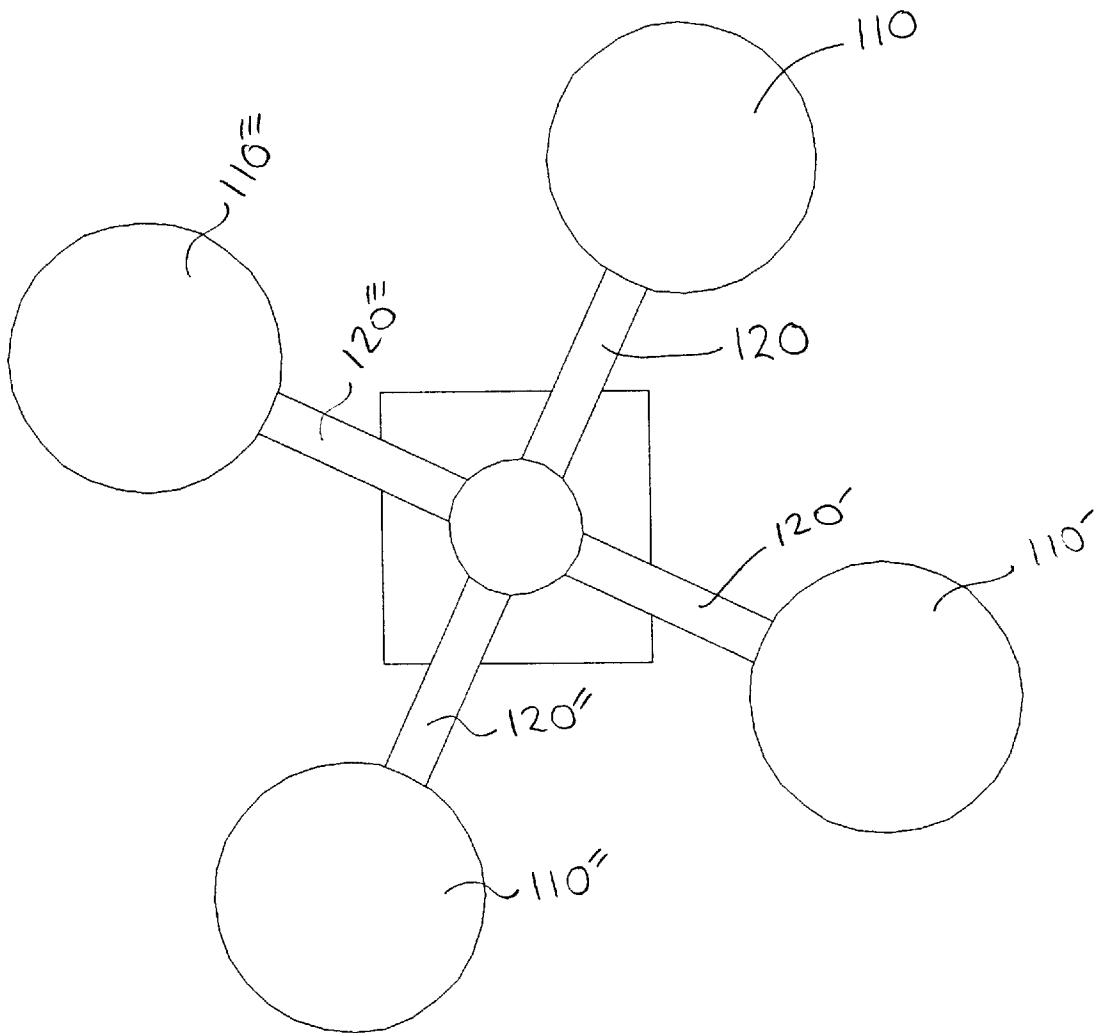

FIGURE 1

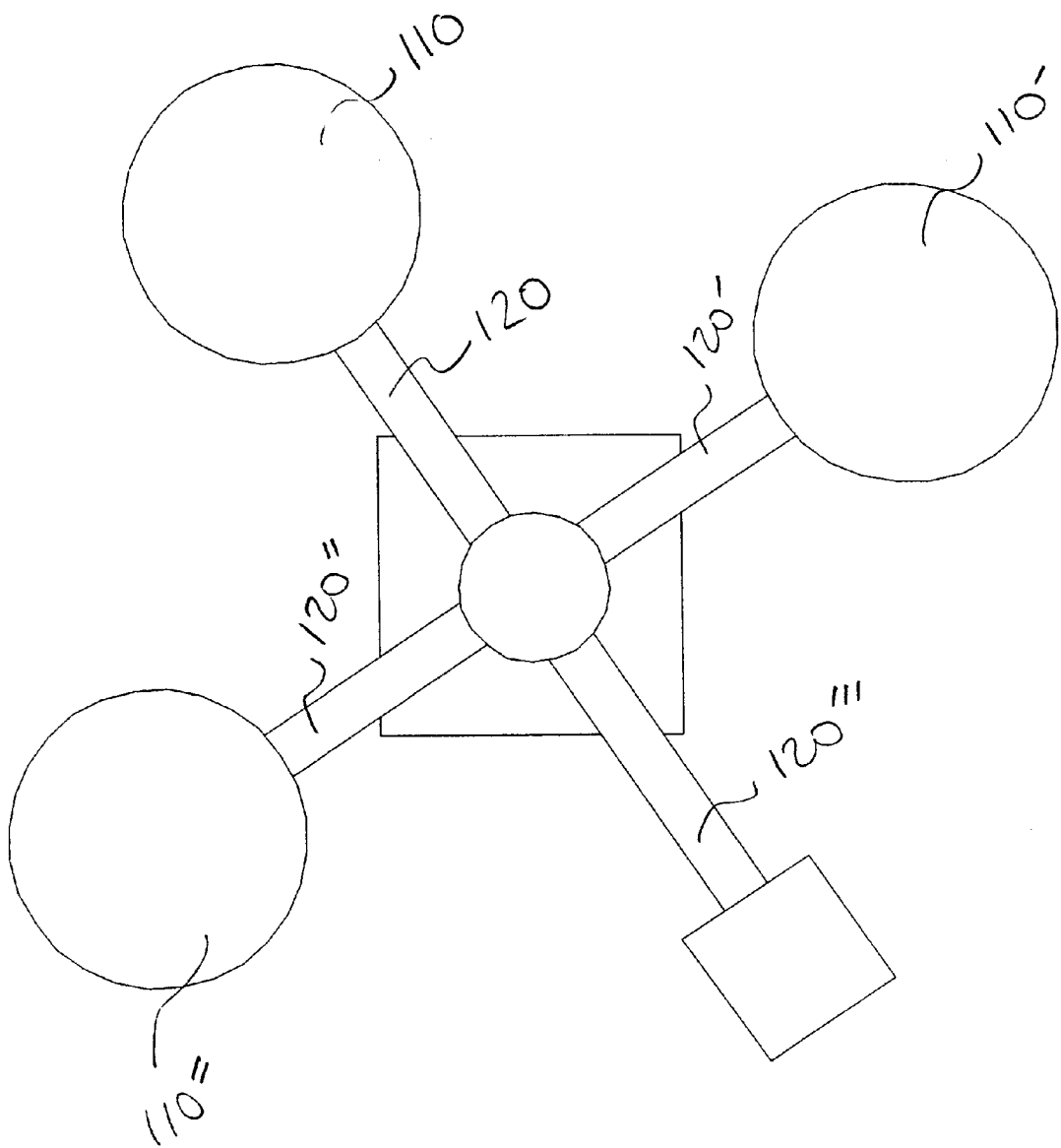

FIGURE 2

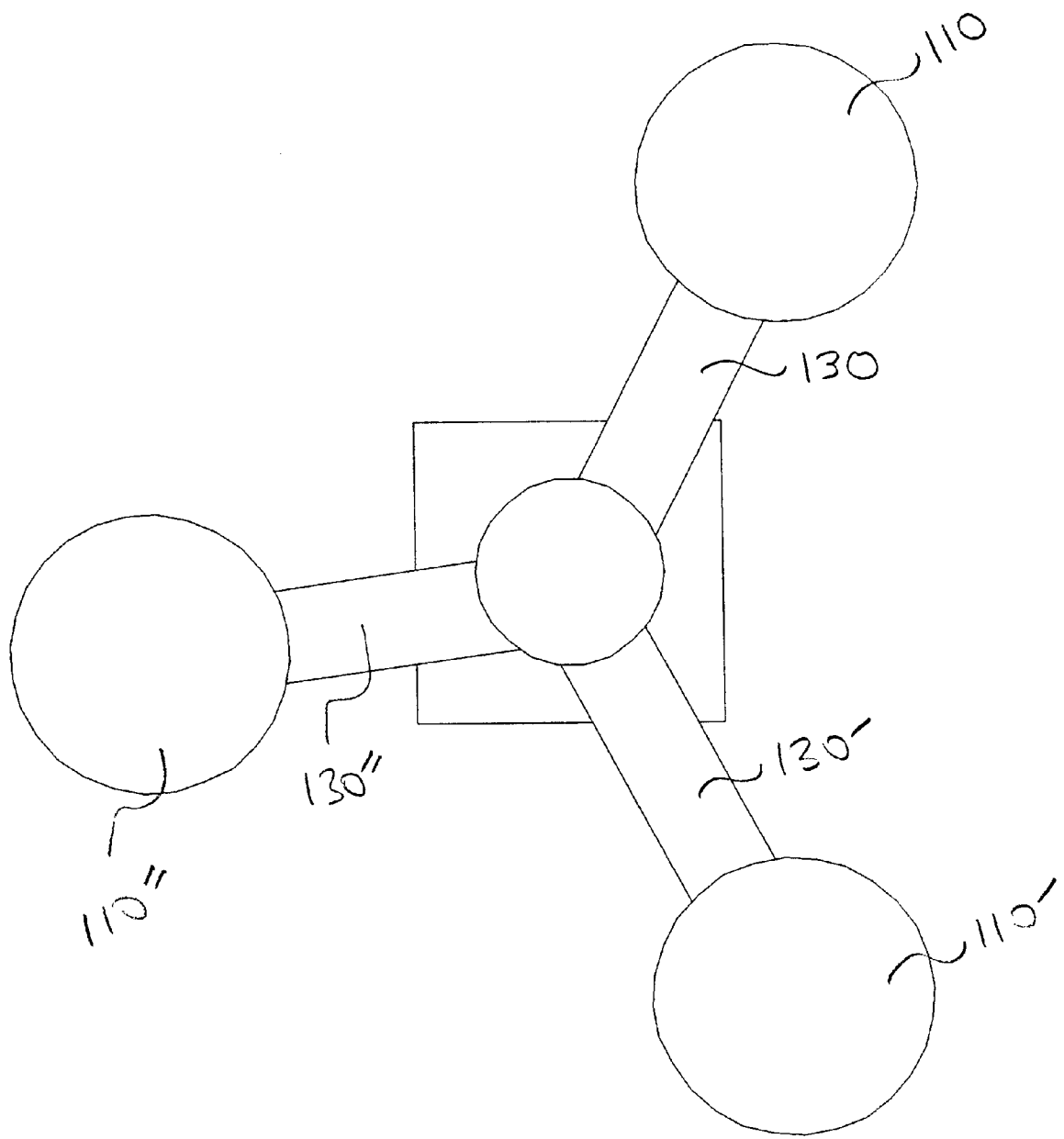

FIGURE 3

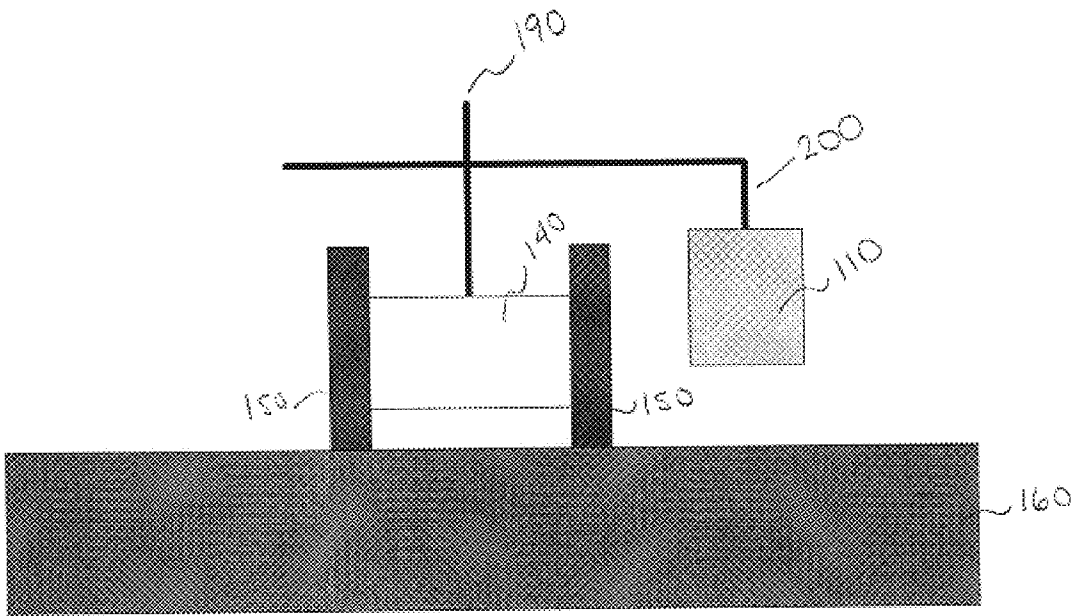

FIGURE 4

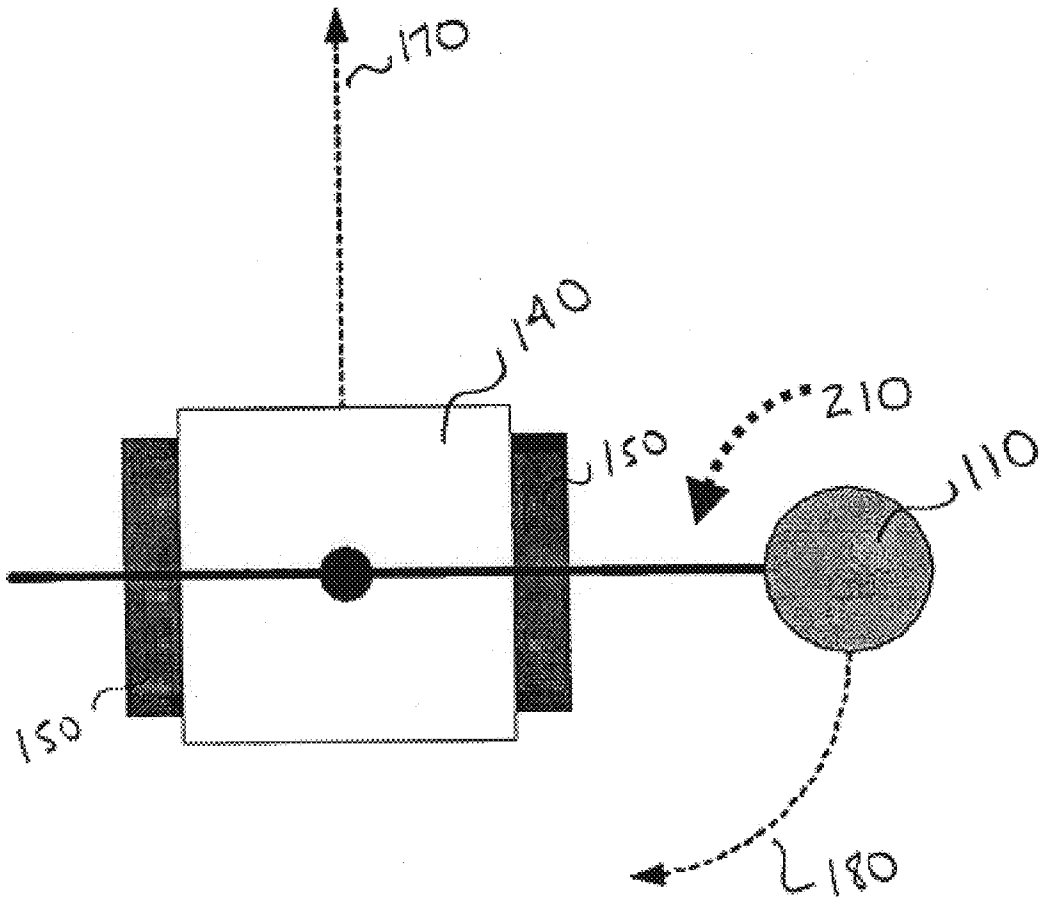

FIGURE 5

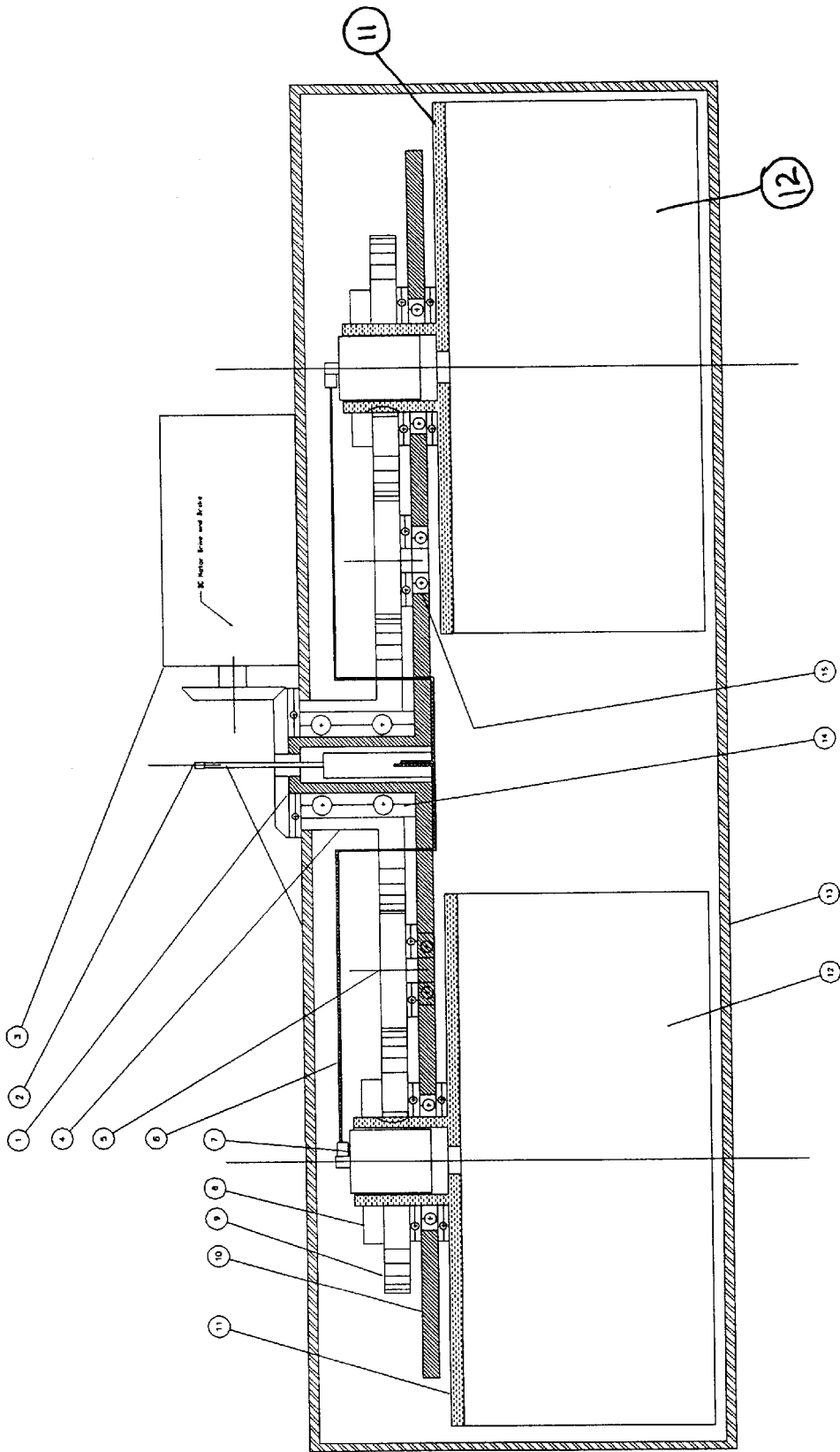

FIGURE 6

## ROTATING SCANNING ANTENNA APPARATUS AND METHOD FOR LOCATING BURIED OBJECTS

### FIELD OF THE INVENTION

This invention relates to a rotating, linearly propelled scanning antenna apparatus and method using radar, sonar, or the like, for use in locating buried objects.

### BACKGROUND

In many applications it is important to be able to quickly and accurately locate objects such as pipes, cables, mines, and barrels that are buried beneath the surface of the earth. Such objects may be located using Ground Penetrating Radar ("GPR") techniques in which electromagnetic waves are transmitted into the ground and reflected. (The term "ground" includes soil, concrete, asphalt, and the like.) The reflections are analyzed according to methods that are well known in the art to determine the location of any object that may be buried there beneath. Other methods well known in the art may also be used, including sonar techniques and inductive techniques.

GPR techniques use transmitting antennas to emit the electromagnetic waves that propagate into the ground and interact with the buried objects. This interaction results in a scattered wave, which is measured by the receiving antenna of the GPR device. By changing the location of the transmitting antenna and recording the corresponding signal that is received and then output by the receiving antenna as a function of time (or frequency) and location, one obtains the radar data from which the information about the buried objects may be extracted. However, for the radar data to be useful, the positions of the measurement locations must be accurately known. Further, it is important for cost efficiency that the system be able to cover a large area in a short period of time; that is, it is important that the system have a high survey speed, which means that the antenna must travel at a high speed.

Such high speed movement may create undesirable mechanical stresses on the antennas. For example, in the simplest scanning system the antenna moves linearly back and forth across the width of the scanning area. This back and forth linear motion requires that the antenna slow down, stop, and then speed up each time it reaches the edge of the scanning area. This type of back and forth movement creates tremendous mechanical stresses in the antennas and survey system when the system is operated at a high survey speed. In fact, these extreme stresses severely limit the survey speed that is obtainable with a linear scanning system.

It is an object of the current invention to provide a rotating GPR system for which the antenna speed and survey speed can be very high without causing excessive mechanical stresses on the antennas and scanning system. With a rotating system, the antennas do not have to slow down when they reach the edge of the scanning area, but instead may operate at a constant speed. As a consequence, the mechanical stresses are much less for a rotating GPR system than for a linear GPR system.

A rotating GPR system is described in U.S. Pat. No. 4,967,199 ("Ground Probing Radar Method and Apparatus") to Gunton et al. and in *Surface Penetrating Radar* by D. J. Daniels (IEE Press, 1996, pp. 200-204). Those references describe a system in which the antennas are interleaved spirals whose axes correspond with the axis of rotation. Further, unlike the present invention, the rotation in these systems is used solely to reduce clutter rather than to move the antenna system along the ground.

### SUMMARY OF THE INVENTION

According to the objects of the present invention, a ground penetrating antenna apparatus is described providing an antenna housing, one or more supporting extensions that are rotatably affixed to the antenna housing about a first axis, at least one antenna that has transmit and receive elements and that is rotatably affixed to a supporting extension about a second axis that is different from the first axis, a linear propulsion mechanism that is attached to the housing so that the housing may be moved over the ground, an impulse generator that is electrically coupled to each transmit element so as to provide pulses to each transmit element, and a sampling unit that is electrically coupled to each receive element so as to receive the output from each receive element.

In one embodiment of the present invention, the ground penetrating antenna apparatus comprises radar antennas. In a further embodiment, a supporting extension is responsive to the linear propulsion mechanism. In yet another embodiment, a supporting extension is coupled to the linear propulsion mechanism via a transmission mechanism.

In one embodiment of the present invention, each supporting extension rotates at a constant rate of rotation. In another embodiment, each supporting extension rotates at a constant rate and the antenna rotates at a constant rate of rotation that is equal in magnitude and opposite in direction to the constant rate of rotation of each supporting extension.

In one embodiment of the present invention, the linear propulsion mechanism comprises a cart that is coupled to the housing and a means for propelling the cart. In another embodiment, the linear propulsion mechanism comprises a self-propelled vehicle that is coupled to the housing.

In one embodiment of the present invention, the ground penetrating antenna apparatus further comprises a data storage device for storing the radar data collected from the sampling unit. In another embodiment, the apparatus further comprises a position indicator that is coupled to the supporting extension and the linear propulsion mechanism. In yet another embodiment, the apparatus further comprises a data storage device for storing the radar data collected from the sampling unit and the position data collected from the position indicator. In another embodiment, each element of the radar data corresponds to a unique element of the position data.

Also in accordance with the objects of the present invention, a method is provided for locating underground objects within a surface area consisting of providing a housing that is adapted for linear movement, providing a supporting extension that is rotationally coupled to the housing about an axis, providing an antenna that is rotationally coupled to a supporting extension about an axis different from said axis of said supporting extension, providing electronics coupled to the antenna that is capable of receiving ground penetrating antenna data, rotating a supporting extension about the axis of the supporting extension, rotating the antenna about the axis of the antenna, moving the housing along a path within the surface area, receiving ground penetrating antenna data at selected positions along the path, recording the ground penetrating antenna data and the selected positions, and analyzing the recorded antenna data and the recorded selected positions to locate underground objects. In one embodiment, the antenna is a radar antenna.

In one embodiment of the present invention, the step of rotating a supporting extension further comprises rotating a supporting extension at a constant rate of rotation. In another



embodiment, the rotating step comprises rotating an antenna at a constant rate that is equal in magnitude and opposite in direction to the constant rate of rotation of a supporting extension.

In one embodiment of the present invention, the step of moving the housing further comprises moving the housing responsively to rotating a supporting extension. In another embodiment, the step of moving the housing further comprises providing a cart that is coupled to the housing and propelling the cart. In yet another embodiment, the step of moving the housing further comprises providing a self-propelled cart that is coupled to the housing. In another embodiment, the recorded antenna data is converted from polar coordinates to rectangular coordinates.

#### BRIEF DESCRIPTION OF THE DRAWINGS

FIG. 1 is a top view of a four antenna apparatus in accordance with the present invention having two arms (i.e., four supporting extensions).

FIG. 2 is a top view of a three antenna apparatus in accordance with the present invention having two arms (i.e., four supporting extensions).

FIG. 3 is a top view of a three antenna apparatus in accordance with the present invention having three spokes (i.e., three supporting extensions).

FIG. 4 is a side view of an apparatus in accordance with the present invention with two antennas.

FIG. 5 is a [top] side view of an apparatus in accordance with the present invention with one antenna.

FIG. 6 is a [side] top view of an apparatus in accordance with the present invention with one antenna.

#### DETAILED DESCRIPTION

One embodiment of the present invention uses a radar system that includes a radar antenna attached to the end of a rotating arm whose axis of rotation is perpendicular to the ground. The system moves along the ground in a linear path while the rotating arm (and the attached antenna) turn about their axes of rotation. With the present system, the radar antennas rotate about axes that are independent of the central axis of rotation. In this way, the present system permits a larger coverage area than is provided by a single axis system. Further, with a multiple axis system, it is possible for the antennas to maintain a fixed orientation regardless of the position of the arm to which they are attached. For example, in a system with two antennas, each antenna may rotate about its own axis at the same rotational speed as the arm but in an opposite direction, thereby maintaining a constant orientation with respect to the linear movement of the system. Typically the forward linear motion of the system will be much slower than the rotating motion of the antenna, so that after one revolution of the antenna, its position will have changed by only a small fraction of the radius of the rotating arm. In a second embodiment, an antenna may be attached to each end of the rotating arm. The width of the survey area is equal to twice the radius of the rotating arm.

Although the embodiment described below includes a single rotating arm with either an antenna at one end or an antenna at both ends, the present invention is not limited to those configurations. Instead, the system could contain multiple arms. For example, referring to FIG. 1, a four-antenna system could contain two arms (i.e., four extensions **120**, **120'**, **120''**, **120'''**) with an antenna **110** at the end of each extension **120**. Alternately, as shown in FIG. 2, a three-antenna system could contain two arms (i.e., four extensions

**120**, **120'**, **120''**, **120'''**) with an antenna **110** at the end of three extensions **120**, **120'**, and **120''**, but no antenna at the end of the fourth extension **120'''**. Instead of arms, the system could use spokes. For example, referring to FIG. 3, a three-antenna system could contain three spokes (i.e., three extensions **130**, **130'**, **130''**), with an antenna **110** at the end of each extension. In this way, any number (odd or even) of antennas can be accommodated using either an arm or a spoke configuration. In this description, the term "supporting extension" will include both arm extensions and spoke extensions. For example, a system with two arms would have four supporting extensions, whereas a system with three spokes would have three supporting extensions.

FIG. 4 and FIG. 5 show a side view and a top view, respectively, of a system with an antenna array consisting of a single antenna **110**. Housing **140** is shown with wheels **150** on ground **160**. Also shown are the direction of linear motion **170**, the axis of rotation **190** for the antenna array, the axis of rotation **200** for the single antenna **110**, the direction of rotating motion **180** about axis **190** for the antenna array, and the direction of rotation **210** for antenna **110** about axis **200**.

In one embodiment, the rotating motion is provided by a direct connection to the linear driving mechanism via, for example, a gear mechanism lining the axle of the center arm to an axle of a wheel on a transporting vehicle. With this embodiment, the system moves forward a fixed distance for each 360° of rotational movement. However, it is not necessary for the rotating mechanism to be directly connected to the linear driving mechanism provided that the angular position of the antennas and the position of the axis of rotation are shown at each data collection point. There are two advantages to providing a system in which the rotational mechanism is not linked to the linear driving mechanism. First, with separate systems the rotational speed can remain constant even when the linear speed varies due, for example, to obstacles or hills in the survey area. (Maintaining a constant linear speed under such conditions is difficult.) Second, the motor that provides the rotational motion can be relatively small since only a small amount of work is required to maintain a constant rotational speed.

One such GPR system with an antenna at each end of the rotating arm is shown in FIG. 6. In particular, a separate antenna is attached to each of the two support plates **11**. Each antenna is contained within a separate antenna enclosure **12**. The rotating parts of the system are enclosed within housing **13**. The support plates **11** are attached through thrust bearings **15** to a support collar **10**, which in this embodiment is the rotating arm itself. Each thrust bearing **15** is supported by a collar **8**. The power and data cables for each antenna pass through rotational electrical connectors **7**, connect to cable **6**, and exit housing **13** through the main rotational electrical connector **2**. The axis of rotation of the support carrier **10** is the center of rotational hub **1**, which is attached to bearing **14**. The rotating motion is sustained by drive assembly **3**, which includes an electric motor. The support plates **11** preferably counter-rotate so that the antenna orientation remains constant. This counter-rotation may be achieved by stationary gear **4** that is attached in FIG. 6 directly to support carrier **10**, walling gear **5**, and drive gear **9**.

The linear motion of the system can be provided by a number of different drive systems, all well known in the art. For example, the entire system could be mounted on a cart that is pulled by a vehicle or a winch. Alternately, the system could be mounted directly onto a self-propelled vehicle or the linear motion could be linked directly to the rotational drive mechanism.

5

The angular position of the arm may be determined by using an encoder that measures the angle between the central arm and some fixed direction. Such encoders are well known in the art and may be obtained, for example, from Litton Poly-Scientific of Blacksburg, Virginia.

The position of the system along its linear path can be determined using a number of techniques that are well known in the art. For example, a survey wheel could be attached to the vehicle that moves the system along the ground. Such a survey wheel could provide a measurement of the distance traveled by the vehicle. This information could then be combined with the information from the encoder to provide a record of antenna position corresponding to each radar data collection point. The radar data and the positional data could be continuously merged into a single file for subsequent processing. If the linear motion and the rotational motion remain constant throughout the data collection, then it is not necessary to continuously merge the radar and position data.

Systems for providing the actual radar electronics and methods for analyzing radar data to determine object locations are well known in the art and any such system and method may be used with the present invention. The radar electronics and the mechanical transport and rotational system are connected through various encoders that indicate when the radar system should take a data reading. For example, the radar system could be set to take one measurement for every 10° of rotation of the central arm or for every 1 inch of travel in the forward direction.

With regard to the analysis of the data collected, it should be noted that many analysis routines assume that the input data is provided in a rectangular grid. Although data collected in accordance with the disclosed embodiments will not be in a rectangular grid, it may be converted to a rectangular grid via standard interpolation techniques that are well known to those of skill in the art.

Finally, although this invention has been described via an embodiment based on radar antennas, it is not intended that the present invention be limited to radar signals. One of skill in the art would know of numerous other sensors that could be used to practice the present invention. Further, one of skill in the art would understand how the described embodiment could be modified to accommodate other sensors. For example, the present invention could be used with inductive sensors or sonar sensors. Further, various types of sensors could be combined in the same system.

The present invention, therefore, is well adapted to carry out the objects and obtain the ends and advantages mentioned above, as well as others inherent herein. All presently preferred embodiments of the invention have been given for the purposes of disclosure. Where in the foregoing description reference has been made to elements having known equivalents, then such equivalents are included as if they were individually set forth. Although the invention has been described by way of example and with reference to particular embodiments, it is not intended that this invention be limited to those particular examples and embodiments. It is to be understood that numerous modifications and/or improvements in detail of construction may be made that will readily suggest themselves to those skilled in the art and that are encompassed within the spirit of the invention and the scope of the appended claims.

We claim:

1. A ground penetrating antenna apparatus, comprising:  
an antenna housing;  
at least one supporting extension wherein each said supporting extension is rotatably affixed to said antenna housing about a first axis;

6

at least one antenna, comprising transmit and receive elements, that is rotatably affixed to one of said at least one supporting extension about a second axis different from said first axis;

a linear propulsion mechanism attached to said housing whereby said housing may be moved over the ground; an impulse generator electrically coupled to each of said one or more transmit elements so as to provide pulses to each said transmit element; and,

a sampling unit electrically coupled to each of said one or more receive elements so as to receive the output from each said receive element.

2. The ground penetrating antenna apparatus of claim 1 wherein each said antenna is a radar antenna.

3. The ground penetrating antenna apparatus of claim 2 wherein each said supporting extension is responsive to said linear propulsion mechanism.

4. The ground penetrating antenna apparatus of claim 3 wherein at least one said supporting extension is coupled to said linear propulsion mechanism via a transmission mechanism.

5. The ground penetrating antenna apparatus of claim 2 wherein each said supporting extension rotates at a constant rate of rotation.

6. The ground penetrating antenna apparatus of claim 5 wherein each said antenna rotates at a constant rate of rotation that is equal in magnitude and opposite in direction to said constant rate of rotation of each said supporting extension.

7. The ground penetrating antenna apparatus of claim 2 wherein said linear propulsion mechanism comprises a cart coupled to said housing and a means for propelling said cart.

8. The ground penetrating antenna apparatus of claim 2 wherein said linear propulsion mechanism comprises a self-propelled vehicle coupled to said housing.

9. The ground penetrating antenna apparatus of claim 2 further comprising a data storage device for storing radar data collected from said sampling unit.

10. The ground penetrating antenna apparatus of claim 2 further comprising a position indicator coupled to at least one said supporting extension and said linear propulsion mechanism.

11. The ground penetrating antenna apparatus of claim 10 further comprising a data storage device for storing radar data collected from said sampling unit and position data collected from said position indicator.

12. The ground penetrating radar apparatus of claim 11 wherein each element of said radar data corresponds to a unique element of said position data.

13. A method of locating underground objects within a surface area comprising:

providing a housing adapted for linear movement;

providing a supporting extension rotationally coupled to said housing about an axis;

providing an antenna rotationally coupled to said supporting extension about an axis different from said axis of said supporting extension;

providing electronics coupled to said antenna capable of receiving ground penetrating antenna data;

rotating said supporting extension about said axis of said supporting extension;

rotating said antenna about said axis of said antenna;

moving said housing along a path within said surface area;

7

receiving ground penetrating antenna data at selected positions along said path;

recording said ground penetrating antenna data and said selected positions;

analyzing said recorded antenna data and said recorded selected positions to locate said underground objects.

14. The method of claim 13 wherein said antenna is a radar antenna.

15. The method of claim 14 wherein said rotating said supporting extension step further comprises rotating said supporting extension at a constant rate of rotation.

16. The method of claim 15 wherein said rotating said antenna further comprises rotating said antenna at a constant rate that is equal in magnitude and opposite in direction to said constant rate of rotation of said supporting extension.

8

17. The method of claim 14 wherein said moving said housing step further comprises moving said housing responsively to rotating said supporting extension.

18. The method of claim 14 wherein said moving said housing step further comprises:

providing a cart coupled to said housing; and, propelling said cart.

19. The method of claim 14 wherein said moving said housing step further comprises providing a self-propelled cart couples to said housing.

20. The method of claim 14 further comprising the step of converting said recorded antenna data from polar coordinates to rectangular coordinates.

\* \* \* \* \*